

StorageTek Storage Management Component (MSP Implementation)

Configuration and Administration Guide

Version 6.2



Part Number: E20865-01
February 2011

Submit comments about this document to STP_FEEDBACK_US@ORACLE.COM.

Oracle welcomes your comments and suggestions for improving this book. Contact us at STP_FEEDBACK_US@ORACLE.COM. Please include the title, part number, issue date, and revision.

Copyright ©2009, 2011, Oracle and /or its affiliates. All rights reserved.

This software and related documentation are provided under a license agreement containing restrictions on use and disclosure and are protected by intellectual property laws. Except as expressly permitted in your license agreement or allowed by law, you may not use, copy, reproduce, translate, broadcast, modify, license, transmit, distribute, exhibit, perform, publish, or display any part, in any form, or by any means. Reverse engineering, disassembly, or decompilation of this software, unless required by law for interoperability, is prohibited.

The information contained herein is subject to change without notice and is not warranted to be error-free. If you find any errors, please report them to us in writing.

If this is software or related software documentation that is delivered to the U.S. Government or anyone licensing it on behalf of the U.S. Government, the following notice is applicable:

U.S. GOVERNMENT RIGHTS Programs, software, databases, and related documentation and technical data delivered to U.S. Government customers are "commercial computer software" or "commercial technical data" pursuant to the applicable Federal Acquisition Regulation and agency-specific supplemental regulations. As such, the use, duplication, disclosure, modification, and adaptation shall be subject to the restrictions and license terms set forth in the applicable Government contract, and, to the extent applicable by the terms of the Government contract, the additional rights set forth in FAR 52.227-19, Commercial Computer Software License (December 2007). Oracle USA, Inc., 500 Oracle Parkway, Redwood City, CA 94065.

This software or hardware is developed for general use in a variety of information management applications. It is not developed or intended for use in any inherently dangerous applications, including applications which may create a risk of personal injury. If you use this software or hardware in dangerous applications, then you shall be responsible to take all appropriate fail-safe, backup, redundancy, and other measures to ensure the safe use. Oracle Corporation and its affiliates disclaim any liability for any damages caused by use of this software or hardware in dangerous applications.

Oracle is a registered trademark of Oracle Corporation and /or its affiliates. Oracle and Java are registered trademarks of Oracle and /or its affiliates. Other names may be trademarks of their respective owners.

AMD, Opteron, the AMD logo, and the AMD Opteron logo are trademarks or registered trademarks of Advanced Micro Devices. Intel and Intel Xeon are trademarks or registered trademarks of Intel Corporation. All SPARC trademarks are used under license and are trademarks or registered trademarks of SPARC International, Inc. UNIX is a registered trademark licensed through X/Open Company, Ltd.

This software or hardware and documentation may provide access to or information on content, products, and services from third parties. Oracle Corporation and its affiliates are not responsible for and expressly disclaim all warranties of any kind with respect to third-party content, products, and services. Oracle Corporation and its affiliates will not be responsible for any loss, costs, or damages incurred due to your access to or use of third-party content, products, or services.

Contents

Preface	17
What's New?	25
1. Introduction	29
2. SMC and StorageTek TapePlex Management	31
Overview	31
SMC TAPEPlex and SERVER Commands	31
Primary and Secondary Servers	32
Client Communication Monitor Subtask	32
The StorageTek HTTP Server for MSP	33
Allocation and Multiple StorageTek TapePlexes	33
SMC Configuration Scenarios	34
Scenario 1: SMC and a Single HSC TapePlex (Local)	34
Scenario 2: SMC and a Single HSC TapePlex (Remote)	36
Scenario 3: SMC and a Single HSC TapePlex with One Local and One Remote (alternate) Path	38
Scenario 4: SMC and a Single HSC TapePlex with Multiple Remote Server Paths	40
Scenario 5: SMC with Two TapePlexes; One Local and One Remote	42
Scenario 6: SMC with Two TapePlexes; One Local and One Remote with Multiple Paths	44
Client/Server Drive Address Mapping	46
SMC Drive Type Information Synchronization	48
Specifying Drive Type Information Using SMC UNITAttr Commands	48
SMC TapePlex Selection	52

3. Starting the SMC	53
Overview	53
Creating the SMC START Procedure	54
SMC EXEC Statement	56
Executing the SMC START Procedure	58
MSP START Command Syntax	58
MSP START Command Parameters	58
4. Policy	59
Overview	59
The SMC POLICY Command	59
SMC Policy and the TAPEREQ Control Statement	60
SMC Policy and Esoteric Preferencing	62
Example	64
5. Allocation	65
Overview	65
SMC Drive Exclusion	66
Allocation User Exits	67
Drive Exclusion - Specific Volumes	68
Drive Exclusion - Scratch Volumes	70
Affinity Separation	73
Affinity Head-Of-Chain	73
User Policy Influence on Affinity Separation	73
Drive Prioritization	74
Deferring Mounts	75
SMC Allocation Exceptions	75
SMC Allocation Processing - JES Operating System Hooks	76
SSI23 Dynamic Allocation	76
SSI24 Common Allocation	76
6. Message Handling	77
Overview	77
User Directed Message Handling	77
Message Handling Policies	78

MSP Policies	78
SMC Policies	78
Tape Management System Support	78
SMC Swap Processing	79
HSC Mount-Related Messages	80
Managing HSC Mounts from the SMC Client	81
7. Commands and Control Statements	83
Overview	83
Issuing SMC Commands	84
Issuing SMC Commands Using the MSP Modify Command	84
Issuing SMC Commands Using the SMC Command Prefix	85
Specifying SMC Commands in the SMCCMDS or SMCPARMS Data Set	85
SMC Commands that Specify JOBname, STEPname, and PROCstep	86
ALLOCDef Command	87
Syntax	87
Command Name	88
Parameter Descriptions	88
Examples	91
ALLOCJob Command	92
Syntax	92
Command Name	93
Parameter Descriptions	93
Examples	95
CMDDef Command	96
Syntax	96
Command Name	96
Parameter Descriptions	96
Example	97
COMMtest Command	98
Syntax	98
Command Name	99
Parameter Descriptions	99
Example	100

Display DDrive Command	101
Syntax	101
Command Name	102
Parameter Descriptions	102
Example	103
Display Volume Command	104
Syntax	104
Command Name	104
Parameter Descriptions	104
Example	105
DRIVemap Command	106
Syntax	106
Command Name	107
Parameter Descriptions	107
Example	107
LIBrary Command (SMC 6.1)	108
LlSt Command	109
Syntax	109
Command Name	109
Parameter Descriptions	109
Example	110
LOG Command	111
Syntax	111
Command Name	112
Parameter Descriptions	112
Example	113
MOUNTDef Command	114
Syntax	114
Command Name	115
Parameter Descriptions	115
Example	116
MSGDef Command	117
Syntax	117

Command Name	118
Parameter Descriptions	118
Example	119
MSGJob Command	120
Syntax	120
Command Name	120
Parameter Descriptions	120
Example	122
POLicy Command	123
Syntax	124
Command Name	125
Parameter Descriptions	125
Example	129
READ Command	130
Syntax	130
Command Name	130
Parameter Descriptions	130
Example	131
RESYNChronize Command	132
Syntax	132
Command Name	133
Parameter Descriptions	133
Route Command	134
Syntax	134
Command Name	135
Parameter Descriptions	135
Examples	135
SERVer Command	137
Syntax	137
Command Name	138
Parameter Descriptions	138
Example	141
STORMNGR Command	142

Syntax	142
Command Name	143
Parameter Descriptions	143
TAPEPlex Command	144
Syntax	145
Command Name	146
Parameter Descriptions	146
Examples	148
TAPEREQ (Tape Request) Control Statement	149
Syntax	150
Control Statement Name	151
Parameters	151
Examples	159
Disabling a TAPEREQ Definition	160
Order Sensitivity of TAPEREQ Control Statements and Tape Policy Attributes Selected from Multiple TAPEPREQ Control Statements	160
TCPip Command	161
Syntax	161
Command Name	161
Parameter Descriptions	161
Example	163
TRace Command	164
Syntax	164
Command Name	165
Parameter Descriptions	165
Examples	167
TREQDef Command	169
Syntax	169
Command Name	169
Parameter Descriptions	169
Example	170
UEXit Command	171
Syntax	171
Command Name	172

Parameter Descriptions	172
Example	173
UNITAttr Command	174
Syntax	175
Command Name	175
Parameter Descriptions	175
Example	176
USERMsg Command	177
Syntax	177
Command Name	177
Parameter Descriptions	177
Example	178
8. Recovery Procedures	179
Overview	179
SMC Recovery Procedures (JES)	179
Inactive SMC - Active TapePlex	179
Active SMC - Inactive TapePlex	180
Automating Mount Requests for Inactive TapePlexes	180
Lost MSP Mount Requests for Active TapePlexes	180
9. Utilities	181
Overview	181
SMC Utility Return Codes and Messages	181
Tape Management Extract Utility (SMCUDBX)	182
Running the SMC Scratch Extract Utility	183
Using SMCUDBX with CA-1 Release 4.9 or Below	185
Using SMCUDBX with CA-DYNAM/TLMS Release 5.3 or Below	185
Specifying Values for the PARM Parameter	186
Parameter Descriptions	186
Sample JCL	188
Sample Output	189
SMCUUUI Utility	190
POLicy and TAPEREQ Batch Test Utility (SMCUTRQ)	195

	Sample JCL	195
	Control Cards	196
	Sample Input	197
	Sample Output	198
10.	Messages	199
	Overview	199
	Message Format	199
	Message Descriptions	200
	Variable Definitions	200
	Message Change Summary	201
	New Messages	201
	Changed Messages	202
	Deleted Messages	202
	SMC System Message Listing	203
	SMC Utility Message Listing	256
11.	Return Codes	259
	UI Return Codes	259
	SMC ASCOMM Return Codes	261
	SMC Communication Component Return Codes	262
12.	Using the StorageTek HTTP Server	265
	Overview	265
	Creating the HTTP Server START Procedure	266
	Customizing the HTTP Server Parameter File	267
	Configuration Parameters	267
	Network Parameters	268
	CGI Parameters	268
	Performance Considerations	268
	Starting the HTTP Server	269
	Stopping the HTTP Server	269
	Displaying HTTP Server Status	269
	Tracing the SMC in the HTTP Server	270
	StorageTek HTTP Server Messages	270

Message Format	270
Message Change Summary	271
New Messages	271
Message Listing	271
A. Intercepted Messages	281
Fujitsu Operating System Messages	281
Tape Management System Messages	283
CA-1 Messages	283
CONTROL-M/TAPE (formerly CONTROL-T) Messages	284
B. MEDia, RECtech, and MODel Values	285
Media Type (MEDia)	285
Recording Technique (RECtech)	288
MODel Type (MODel)	292
C. TAPEREQ Conversion Script (POLCVT02)	295
Overview	295
Executing the Script	296
D. SMC Compatibility Matrix	297
E. SMC Interaction with Other Software	299
Automated Operations	299
Open Type J	299
SAMS: DISK (DMS)	300
MSP Security Packages	300
Glossary	301

Figures

FIGURE 2-1	SMC and a Single HSC TapePlex (Local)	34
FIGURE 2-2	SMC and a Single HSC TapePlex (Remote)	36
FIGURE 2-3	SMC and a Single HSC TapePlex with One Local and One Remote (alternate) Path	38
FIGURE 2-4	SMC and a Single HSC TapePlex with Multiple Remote Server Paths	40
FIGURE 2-5	SMC with Two TapePlexes; One Local and One Remote	42
FIGURE 2-6	SMC with Two TapePlexes; One Local and One Remote with Multiple Paths	44
FIGURE 3-1	Sample SMC START Procedure	54
FIGURE 4-1	Sample SMCCMDS Data Set	60
FIGURE 9-1	Scratch Synchronization Between SMC Client host and HSC CDS	182
FIGURE 9-2	Sample JCL for Scratch Extraction Utility	188
FIGURE 9-3	Scratch Extraction Utility Sample Output Messages	189
FIGURE 9-4	JCL to Execute the SMCUUUI Utility	191
FIGURE 9-5	JCL to Execute the SMCUTRQ Utility	195
FIGURE 9-6	SMCUTRQ Utility Sample Output	198
FIGURE 12-1	Sample HTTP Server START Procedure	266

Tables

TABLE 2-1	SMC Client/Server Drive Address Mapping Scenarios	47
TABLE 5-1	Drive Exclusion Levels (Specific Request)	68
TABLE 5-2	Drive Exclusion Levels (Scratch Request)	70
TABLE 7-1	Alternate Device Default Value	157
TABLE 10-1	Variable Data Definitions	200
TABLE 11-1	General UUI Return Codes	259
TABLE 11-2	ASCOMM Return Codes	261
TABLE 11-3	SMC Communication Component Return Codes	262
TABLE 11-4	SMC Communication Component TCP/IP Routine Return Codes	262
TABLE 11-5	SMC CGI Routine/HTTP Server Routine Return Codes	263
TABLE A-1	Intercepted Operating System Messages	282
TABLE A-2	Tape Management System Messages - CA-1	283
TABLE A-3	CONTROL-M/TAPE Messages	284
TABLE B-1	Media Types	285
TABLE B-2	Media Type Defaults	287
TABLE B-3	Recording Techniques	288
TABLE B-4	Recording Technique Defaults	291
TABLE B-5	Model Types	292
TABLE D-1	SMC Compatibility Matrix	297

Preface

This publication describes how to configure and manage Oracle's StorageTek Storage Management Component (SMC). It is intended for storage administrators, system programmers and operators responsible for configuring and maintaining the SMC software at their site.

Related Publications

The following publications provide additional information about specific topics relating to the use of the Storage Management Component (SMC):

StorageTek Nearline Control Solution (NCS)

- *NCS Installation Guide*
- *NCS User Exit Guide*
- *NCS/VTCS XML Guide*

StorageTek Host Software Component (HSC)

- *HSC Configuration Guide*
- *HSC Operator's Guide*
- *HSC System Programmer's Guide*
- *HSC Messages and Codes Guide*

StorageTek Virtual Tape Control System (VTCS)

- *Beyond the Basics - VTCS Leading Edge Techniques*
- *Installing and Configuring VTCS*
- *Introducing VTCS*
- *Managing VTCS*
- *VTCS Messages and Codes Guide*
- *VTCS Command and Utility Reference*

Documentation, Support, and Training

Function	URL
Oracle Home	http://oracle.com
Documentation	http://oracle.com/technetwork/indexes/documentation/index.html
Support	http://www.oracle.com/us/support/044752.html
Training	http://www.oracle.com/global/us/education/sun_select_country.html

Additional Information

Conventions for Reader Usability

Product Names

SMC refers to the MSP implementation of Oracle's StorageTek Storage Management Component.

HSC refers to the MSP implementation of Oracle's StorageTek Host Software Component.

Typographic

Some JCL examples in this guide include *italic* type. Italic type is used to indicate a variable. You must substitute an actual value for these variables.

The use of mixed upper and lower case characters for commands, control statements, and parameters indicates that lower case letters may be omitted to form abbreviations. For example, you may simply enter POL when executing the POLicy command.

Syntax Flow Diagrams

Syntax flow diagramming conventions include the following:

Flow Lines

Syntax diagrams consist of a horizontal base line, horizontal and vertical branch lines, and the text for a command, control statement, macro, or utility. Diagrams are read left to right, and top to bottom. Arrows indicate flow and direction.

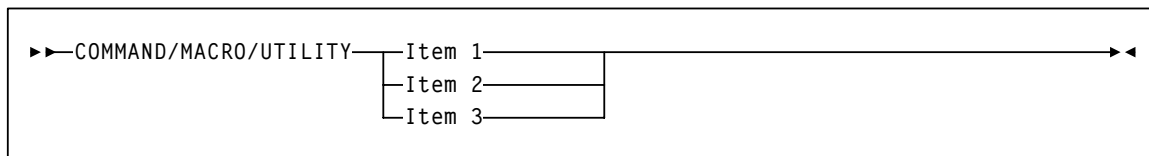

Single Required Choice

Branch lines (without repeat arrows) indicate that a single choice must be made. If one of the items to choose from is positioned on the baseline of the diagram, one item must be selected.

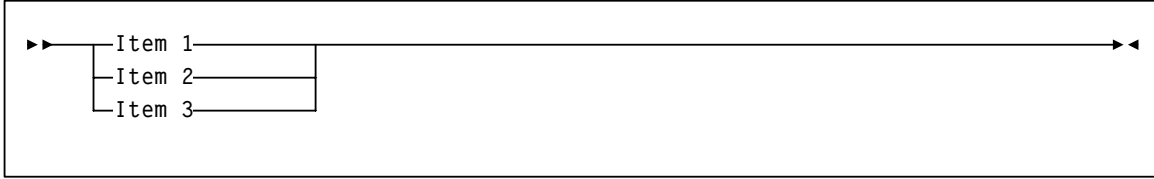

Single Optional Choice

If the first item is positioned on the line below the baseline, one item may be optionally selected.

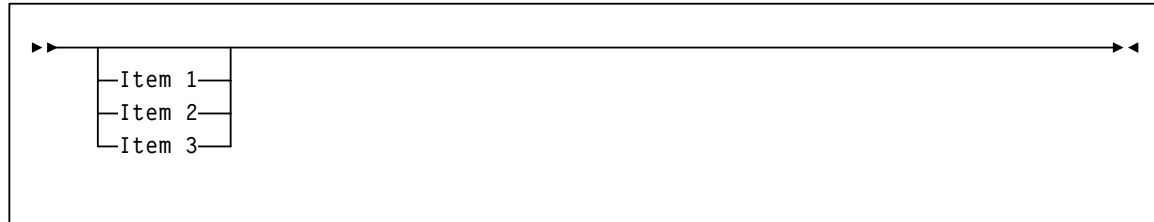

Defaults

Default values and parameters appear above the baseline.

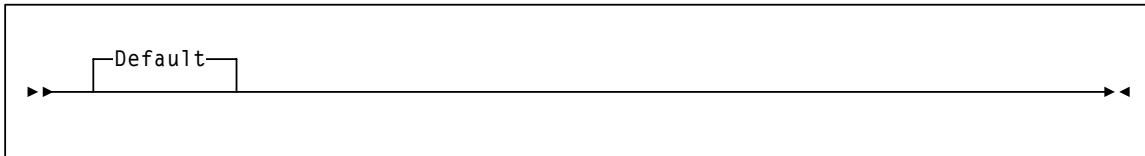

Some keyword parameters provide a choice of values in a stack. When the stack contains a default value, the keyword and the value choices are placed below the baseline to indicate that they are optional, and the default value appears above the keyword line.

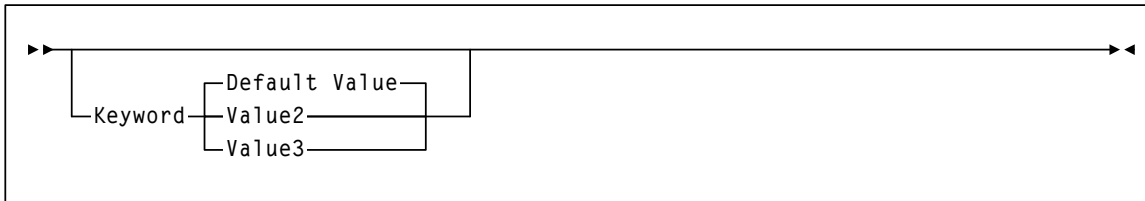

Repeat Symbol

A repeat symbol indicates that more than one choice can be made or that a single choice can be made more than once. The following example indicates that a comma is required as the repeat delimiter.



Keywords

All command keywords are shown in all upper case or in mixed case. When commands are not case sensitive, mixed case implies that the lowercase letters may be omitted to form an abbreviation.

Variables

Italic type is used to indicate a variable.

Alternatives

A bar (|) is used to separate alternative parameter values.

Optional

Brackets [] are used to indicate that a command parameter is optional.

Delimiters

If a comma (,), a semicolon (;), or other delimiter is shown with an element of the syntax diagram, it must be entered as part of the statement.

Ranges

An inclusive range is indicated by a pair of elements of the same length and data type, joined by a dash. The first element must be strictly less than the second element.

A hexadecimal range consists of a pair of hexadecimal numbers (for example, 0A2-0AD, or 000-0FC).

A decimal range consists of a pair of decimal numbers (i.e., 1-9, or 010-094). Leading zeros are not required. The decimal portion is referred to as an incremental range. The character positions of the incremental portion of both range elements must match, and the non incremental characters of the first element must be identical to those of the second element.

A numeric VOLSER range (*vol-range*) consists of a pair of VOLSER elements containing a decimal numeric portion of 1 to 6 digits (for example, ABC012-ABC025, or X123CB-X277CB). The decimal portion is referred to as an incremental range. The following additional restrictions apply:

- The character positions of the incremental portion of both range elements must match.
- The non incremental characters of the first element must be identical to those of the second element.
- You cannot increment two portions of a range element. If 111AAΔ is the first element, you cannot specify 112AAB for the second element.
- If a VOLSER range contains more than one decimal portion, any portion is valid as the incremental range. For example:

A <u>00</u> B <u>00</u>	the largest range that can be specified is A00B00 through A99B99.
A <u>0</u> B <u>0</u> CC	the largest range that can be specified is A0B0CC through A9B9CC.
<u>00</u> XXX	the largest range that can be specified is 000XXX through 999XXX.

An alphabetic VOLSER range (*vol-range*) consists of a pair of VOLSER elements containing an incremental portion of 1 to 6 characters (for example, 000AAA-000ZZZ, or 9AAA55-9ZZZ55). This portion is referred to as an incremental range. The following additional restrictions apply:

- The character positions of the incremental portion of both range elements must match.
- The non incremental characters of the first element must be identical to those of the second element.
- You cannot increment two portions of a range element. If 111AAΔ is the first element, you cannot specify 112AAB for the second element.
- The alphabetic portion of the VOLSER range is defined as being from character A to Z. To increment multi-character sequences, each character increments to Z. For instance, ACZ is part of the AAA-AMM range. Examples are:

A <u>00</u> A0-A <u>99</u> A0	increments VOLSERs A00A0 through A09A0, then A10A0 through A99A0.
9 <u>AA</u> 9A-9 <u>ZZ</u> 9A	increments VOLSERs 9AA9A through 9AZ9A, then 9BA9A through 9ZZ9A.
111 <u>AAA</u> -111 <u>ZZZ</u>	increments VOLSERs 111AAA through 111AAZ, then 111ABA through 111ZZZ
999 <u>AM</u> 8-999 <u>CM</u> 8	increments VOLSERs 999AM8 through 999AZ8, then 999BA8 through 999CM8
A3 <u>BZZ</u> 9-A3 <u>CDE</u> 9	increments VOLSERs A3BZZ9 through A3CAA9, then A3CAB9 through A3CDE9
<u>AAAAAA</u> - <u>AAACCC</u>	increments VOLSERs AAAAAA through AAAAAZ, then AAAABA through AAACCC
<u>CCNNN</u> - <u>DDNNN</u>	increments VOLSERs CCNNN through CCNNZ, then CCCNOA through DDDNNN *

* **Caution:** This is a very large range.

The number of volumes in an alphabetic VOLSER range depends on the number of elements in the incrementing portion of the VOLSER range. For an A to Z range in each character position, the number of volumes can be calculated by 26 to the power of the number of positions that are being incremented.

A-Z	26^1	26
AA-ZZ	26^2	676
AAA-ZZZ	26^3	17,576
AAAA-ZZZZ	26^4	456,976
AAAAA-ZZZZZ	26^5	11,881,376
AAAAAA-ZZZZZZ	26^6	308,915,776

Lists

A list consists of one or more elements. If more than one element is specified, the elements must be separated by a comma or a blank space, and the entire list must be enclosed in parentheses.

Blanks

Keyword parameters and values may be separated by any number of blanks.

Control Statements

The standard syntax conventions for control statements are as follows:

- The only valid control statement information area is from column 1 to column 72. Columns 73-80 are ignored.
- Parameters may be separated by one or more blanks or a comma.
- A value is associated with a parameter by an equal (=) sign or by enclosing the value in parentheses, and concatenating it immediately after the parameter.
- Case (upper or lower) is ignored in actual control statements.
- Continuations are supported by including a plus (+) sign at the end of the line to be continued. A control statement is terminated if the statement is not continued.
- /* and */ can be used to enclose comments in the job stream. Comments can be continued over multiple lines, but cannot be nested.

PARMLIB members **must** include a /*...*/ comment as the **first** control statement. Otherwise, the old format is assumed. Comments in the old format must begin with an asterisk (*) in column 1.

For definition data sets (e.g., VOLATTRs, UNITATTRs and TAPEREQs), comments **must** be in the new format (/*...*/).

- Asterisk (*) comments are **not** allowed.
- A /*...*/ comment in the first line is **not** required.
- The maximum length for a control statement is 1024 characters.

What's New?

This publication includes information about the following SMC enhancements:

Revision 01

Enhancement	Primary Location
Support for Oracle's StorageTek T10000C tape drive	Appendix B, "MEDia, RECTech, and MODel Values" "POLicy Command" on page 123 "TAPEREQ (Tape Request) Control Statement" on page 149 "UNITAttr Command" on page 174
Support for Oracle's StorageTek Virtual Library Extension (VLE) 1.0	"COMMtest Command" on page 98 "Route Command" on page 134 "SERVer Command" on page 137 "STORMNGR Command" on page 142
Message changes and additions	Chapter 10, "Messages"

Revision B

Enhancement	Primary Location
The client communication monitor subtask feature provides periodic validation of active communication paths for all non-disabled TapePlexes. This feature is enabled using the MONitor parameter on the TCPip command.	“Client Communication Monitor Subtask” on page 32 “TCPip Command” on page 161
Support for Oracle’s StorageTek T10000 and T10000B tape drives (SMC 6.1 and later)	Appendix B, “MEDia, RECtech, and MODel Values” “POLicy Command” on page 123 “TAPEREQ (Tape Request) Control Statement” on page 149 “UNITAttr Command” on page 174
Support for Oracle’s StorageTek T9840D tape drive (SMC 6.1 and later)	Appendix B, “MEDia, RECtech, and MODel Values” “POLicy Command” on page 123 “TAPEREQ (Tape Request) Control Statement” on page 149 “UNITAttr Command” on page 174
Message changes and additions	Chapter 10, “Messages”

Revision A

Enhancement	Primary Location
The new SMC POLicy command, in conjunction with the TAPEREQ control statement, provides an improved method for tape policy management.	“POLicy Command” on page 123
The new SMC TAPEPlex command replaces the SMC LIBrary command. Additionally, the TAPEPlex parameter replaces the LIBrary parameter for the SMC SERVer and UNITAttr commands. Note: Existing LIBrary commands are supported for compatibility with SMC 6.1. A TapePlex (formerly “library”) is a single StorageTek™ hardware configuration, normally represented by a single HSC Control Data Set (CDS). A TapePlex may contain multiple Automated Cartridge Systems (ACSs) and Virtual Tape Storage Subsystems (VTSSs). The TAPEPlex command includes a STATus parameter, used to list the current status of all TapePlexes or a specific named TapePlex.	“TAPEPlex Command” on page 144
The new SMC COMMtest command is used to perform an end-to-end communication test between SMC and defined TapePlexes.	“COMMtest Command” on page 98
The new SMC Display DRive command allows SMC to list drive attributes and TapePlex ownership.	“Display DRive Command” on page 101
The new SMC Display Volume command allows SMC to list volume attributes and TapePlex ownership.	“Display Volume Command” on page 104
The new SMC Route command allows SMC to route HSC Unified User Interface (UUI) commands and VTCS commands to an HSC TapePlex. <ul style="list-style-type: none">■ HSC and VTCS load libraries (SOSLINK and SWSLINK) must be included in the STEPLIB concatenation of the SMC START procedure to support the ability to route HSC and VTCS commands from the SMC to an HSC TapePlex on the same host.■ HSC and VTCS load libraries (SOSLINK and SWSLINK) must be included in the HTTP Server START procedure to support the ability to route HSC and VTCS commands from a remote SMC to a local HSC TapePlex.	“Route Command” on page 134 “Creating the SMC START Procedure” on page 54 “Creating the HTTP Server START Procedure” on page 266
The SMC MSGDef command includes a new VERBoSe parameter, used to produce additional update messages during SMC command processing.	“MSGDef Command” on page 117
The SMC Read command includes the new VOLume and UNIT parameters, used to specify data set location using volume serial number or unit name.	“READ Command” on page 130
The SMC SERVer command includes a new INITFail parameter, used to specify the maximum number of failures (before successful communication is established) allowed before the server path is disabled or placed out of service.	“SERVer Command” on page 137

Enhancement	Primary Location
<p>The SMC TAPEREQ control statement includes two new parameters:</p> <ul style="list-style-type: none"> ■ POLICY parameter, used to specify the name of a policy defined on an SMC POLICY command. ■ VOLSER parameter, used to specify a specific volume id. 	<p>“TAPEREQ (Tape Request) Control Statement” on page 149</p>
<p>The SMC TRACE command includes a new POLICY parameter, used to enable tracing of selected SMC policy name and selection criteria to the job log of the jobname specified in the TRACE command for allocation and mount policies.</p>	<p>“TRACE Command” on page 164</p>
<p>The SMC UNITAttr command includes a new TAPEPlex parameter, used to specify the name of a TapePlex to be associated with the drive before communication is established.</p>	<p>“UNITAttr Command” on page 174</p>
<p>The ZEROscr parameter for the SMC ALLOCDef command allows you to specify the allocation action when there are no scratch volumes in any TapePlex, or in one or more ACSs within a TapePlex in a multiple ACS environment.</p>	<p>“ALLOCDef Command” on page 87</p>
<p>SMC commands are now echoed to the log, along with the user ID associated with the command, for audit trail purposes.</p>	<p>Chapter 7, “Commands and Control Statements” on page 83</p>
<p>The new POLICY and TAPEREQ Batch Test utility (SMCUTRQ) allows you to test POLICY and TAPEREQ lookup for a specified set of criteria.</p>	<p>“POLICY and TAPEREQ Batch Test Utility (SMCUTRQ)” on page 195</p>
<p>The new SMC Unified User Interface utility (SMCUUUI) allows you to issue SMC and HSC UUI commands as well as VTCS requests, from a batch job.</p>	<p>“SMCUUUI Utility” on page 190</p> <p>“UUI Return Codes” on page 259</p>
<p>The SMC TAPEPlex command includes a new STATUS parameter, used to list the current status of all TapePlexes or a specific named TapePlex.</p>	<p>“TAPEPlex Command” on page 144</p>
<p>The POLCVT02 REXX script (included in the SMC SAMPLIB) converts existing TAPEREQ statements to use the new SMC POLICY command.</p>	<p>Appendix C, “TAPEREQ Conversion Script (POLCVT02)” on page 295</p>
<p>JES specific volume request drive exclusion criteria for allocation level 1 is expanded to include the exclusion of virtual drives when a specific virtual volume has been specified as nonlabeled.</p>	<p>“Drive Exclusion - Specific Volumes” on page 68</p>
<p>Message changes, additions and deletions</p>	<p>Chapter 10, “Messages”</p> <p>“StorageTek HTTP Server Messages” on page 270</p>

Introduction

SMC, the Storage Management Component, is the interface between Fujitsu's MSP/EX operating system and Oracle's StorageTek HSC automated library control system. SMC resides on every MSP host that accesses StorageTek real and virtual tape hardware. It operates on JES systems and is a required NCS component. SMC's primary functions are:

- Influencing tape allocation according to hardware requirements and customer policies to ensure that appropriate tape drives are selected
- Intercepting tape management, and operating system mount, dismount, and swap messages and translating them in order to request the required tape hardware functions from the appropriate NCS automated library control system
- Coordinating requests among multiple StorageTek *TapePlexes*

A *TapePlex* (formerly "library"), is a single StorageTek hardware configuration, normally represented by a single HSC Control Data Set (CDS). A TapePlex may contain multiple Automated Cartridge Systems (ACSs) and Virtual Tape Storage Subsystems (VTSSs).

SMC may communicate with any number of TapePlexes, using cross address space facilities to communicate with HSC running on the same host, and TCP/IP to communicate with HSC systems executing on other hosts.

Note – For the purposes of this publication, **HSC** refers to the **MSP** implementation of the StorageTek Host Software Component.

SMC and StorageTek TapePlex Management

Overview

This chapter describes sample SMC configuration scenarios and provides an introduction to the SMC TAPEPlex and SERVer commands as well as the StorageTek HTTP Server for MSP.

The SMC provides the interface between Fujitsu's MSP/EX operating systems and StorageTek NCS library control systems. These library control systems can operate in several ways:

- HSC can operate on the same local MSP host as the SMC.
- HSC can operate on a remote MSP host.
- A combination of local and remote library control systems can be used.

In a simple configuration, with SMC residing on the same MSP host as HSC, the SMC may automatically detect the library control system(s) using MSP interface facilities. However, it is recommended that you use the SMC TAPEPlex command to define the local TapePlexes.

In a more complex configuration, where you wish to define remote HSC systems or enable simple server switching by defining multiple server paths to one or more TapePlexes, you must use the SMC TAPEPlex and SERVer operator commands in addition to the StorageTek HTTP Server for MSP.

SMC TAPEPlex and SERVer Commands

In a configuration including both local and remote TapePlexes, you must use the SMC TAPEPlex command to define all TapePlexes to SMC. Additionally, because a remote TapePlex can be shared by multiple instances of HSC running on different remote hosts, you must use the SMC SERVer command to define the path to each remote host. See [Chapter 7, "Commands and Control Statements"](#) for more information about these commands.

Primary and Secondary Servers

The SMC `SERVER` command defines a named path to a remote library server. The first server defined is considered to be the primary server. Additional servers defined are secondary servers. If a communication error occurs on the primary server during allocation or mount processing, SMC automatically switches communication to the next available secondary server. If a communication error occurs on the secondary server, the SMC automatically switches to the next available secondary server.

Client Communication Monitor Subtask

This feature directs SMC to periodically validate whether an active communication path is available for all non-disabled TapePlexes. It does not require SMC to process an allocation or mount event. Validation automatically occurs at a specified monitor scan interval. This interval is specified using the `MONITOR` parameter on the `TCPip` command.

By default, the communication monitor subtask is automatically enabled at SMC startup. To disable this feature, issue the following SMC command:

```
TCPip MONITOR(OFF)
```

One communication monitor subtask services all TapePlexes defined to SMC and the `TCPip MONITOR` and `PREFprimary` parameters apply to all non-disabled TapePlexes.

If an active communication path is not available for a TapePlex, the monitor subtask attempts to communicate with each defined communication path beginning with the local path (if available) followed by the primary server path and each secondary server path in turn. If the monitor subtask re-establishes communication with the TapePlex, all pending mounts are automatically redriven.

Note –

- The communication monitor subtask eliminates the need to specify the `FAIL` or `INITFAIL` parameters on the `SERVER` command. If specified, these parameters are ignored.
 - The communication monitor subtask does not attempt to re-establish communication with disabled server paths.
 - See [Chapter 7, “Commands and Control Statements”](#) for more information about the SMC `TCPip` and `SERVER` commands.
-

The StorageTek HTTP Server for MSP

The StorageTek HTTP Server for MSP provides the middleware to allow communication between the SMC (client) and a remote HSC subsystem (server). The HTTP server executes as a separate subsystem on the MSP host where the remote HSC subsystem resides. The HTTP Server is **not** required on a host where only the SMC is executing.

Note –

- See [Chapter 12, “Using the StorageTek HTTP Server”](#) for more information about the StorageTek HTTP server.
 - Refer to the *NCS Installation Guide* for information about installing the StorageTek HTTP server.
 - The StorageTek HTTP server is also included with the StorageTek Virtual Storage Manager (VSM) GUI product. However, for performance and security reasons, it is recommended that you do not use the same instance of the HTTP server for both SMC server programs and VSM GUI programs. To execute multiple HTTP server subsystems on a single host, they must each listen on a unique PORT number.
-

Allocation and Multiple StorageTek TapePlexes

If your configuration includes multiple StorageTek TapePlexes (as illustrated in Scenarios 5 and 6 in this chapter), SMC directs the allocation of each DD to the appropriate TapePlex based on TAPEREQ statements, POLICY commands, user exits, specific volume locations, and scratch subpools.

SMC Configuration Scenarios

This section provides several scenarios for SMC in local, remote, and multiple TapePlex configurations.

Scenario 1: SMC and a Single HSC TapePlex (Local)

In this scenario, the SMC and HSC execute on the same MSP host:

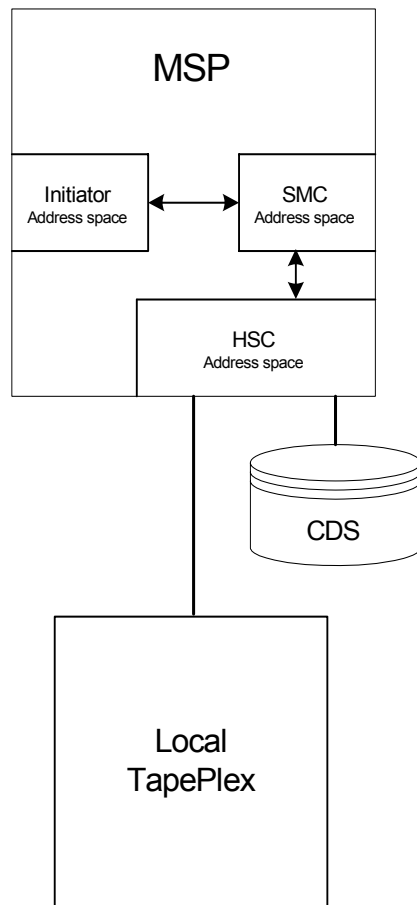

FIGURE 2-1 SMC and a Single HSC TapePlex (Local)

This configuration utilizes three address spaces:

- Initiator Address Space, from which allocation and mount events originate
- SMC Address Space, which intercepts those events
- HSC Address Space, to which SMC sends requests for drive and volume data, and mount requests

It is recommended that you issue TAPEPlex commands to define the local TapePlexes. For example, the following TAPEPlex command is used to define the local HSC TapePlex:

```
TAPEPLEX NAME ( PLEX1 ) LOCSUBSYS ( HSC )
```

where PLEX1 is the desired name of the local TapePlex, and HSC is the local MSP subsystem name for the HSC.

It is recommended that you use the TAPEPlex command to define the TapePlexes, even in a local-only configuration. However, if no TAPEPlex commands are entered, the SMC automatically detects the local HSC TapePlex by scanning the MSP Subsystem Communication Vector Table (SSCVT) chain.

Note – When the SMC receives a TAPEPlex command, automatic TapePlex detection is disabled and only TapePlexes identified with TAPEPlex commands are known to the SMC.

Scenario 2: SMC and a Single HSC TapePlex (Remote)

In this scenario, the SMC communicates with a single HSC on a remote MSP host:

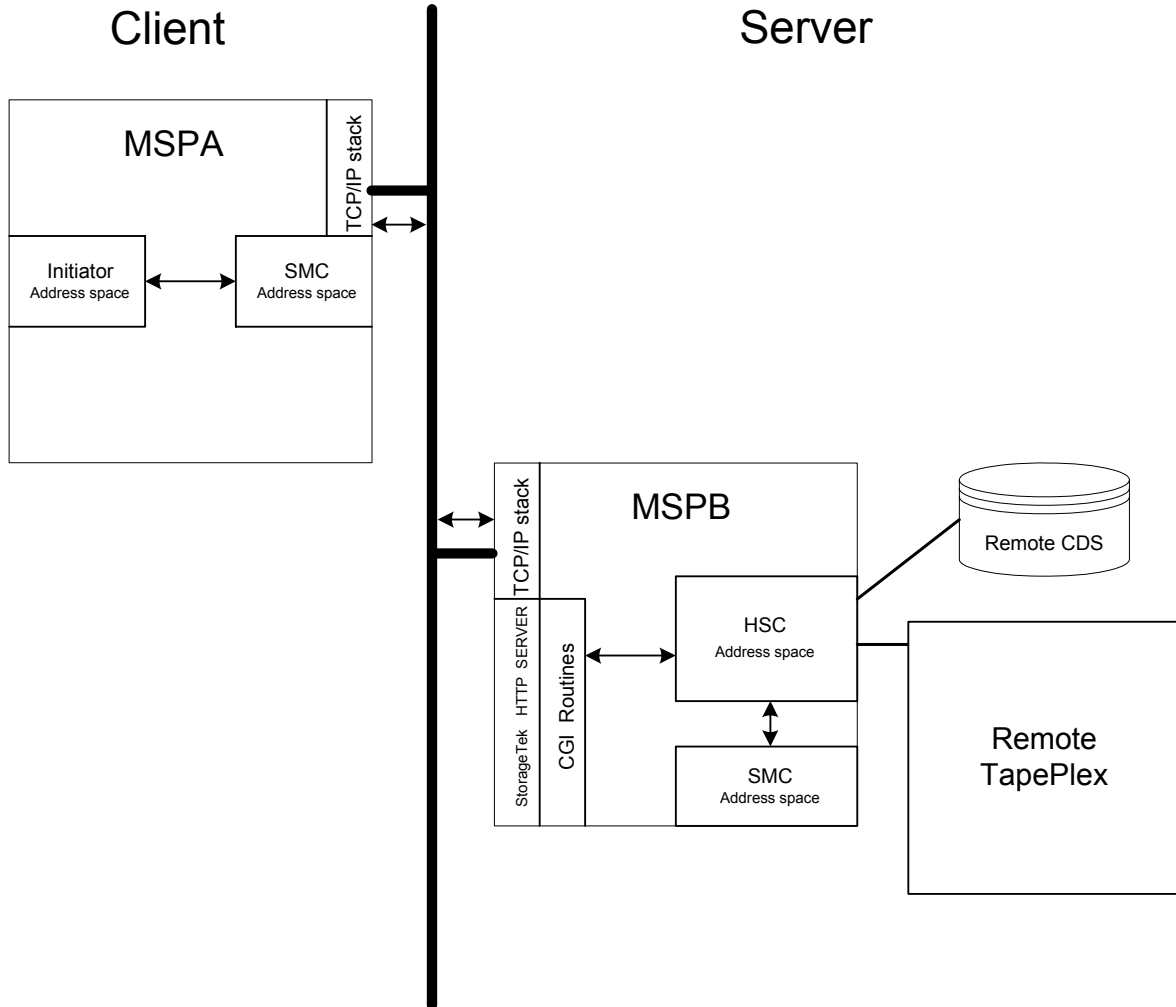

FIGURE 2-2 SMC and a Single HSC TapePlex (Remote)

In this scenario, the SMC acts as a client and the HSC acts as a server.

The SMC Address Space intercepts allocation and mount requests from an Initiator Address Space on MSPA and sends the requests through the TCP/IP stack to the designated StorageTek HTTP server on a remote host (MSPB). The HTTP server on MSPB executes the SMC CGI routine, which routes the request to the HSC executing on MSPB using MSP/EX facilities for cross address space communication.

Any configuration that includes a remote TapePlex requires the StorageTek HTTP server along with TAPEPlex and SERVer commands. The following example illustrates the TAPEPlex and SERVer commands for the SMC on MSPA:

```
TAPEPLEX NAME (PLEX1)  
SERVER NAME (REMPATH) TAPEPLEX (PLEX1) HOST (MSPB)
```

Only the local TapePlex is defined on MSPB:

```
TAPEPLEX NAME (PLEX1) LOCSUB (HSCB)
```

Note – See [“Client/Server Drive Address Mapping” on page 46](#) for additional requirements if different drive addresses are defined between client and server hosts.

Scenario 3: SMC and a Single HSC TapePlex with One Local and One Remote (alternate) Path

When a single TapePlex is shared between multiple MSP hosts, you can define multiple paths to the TapePlex as shown in the following figure:

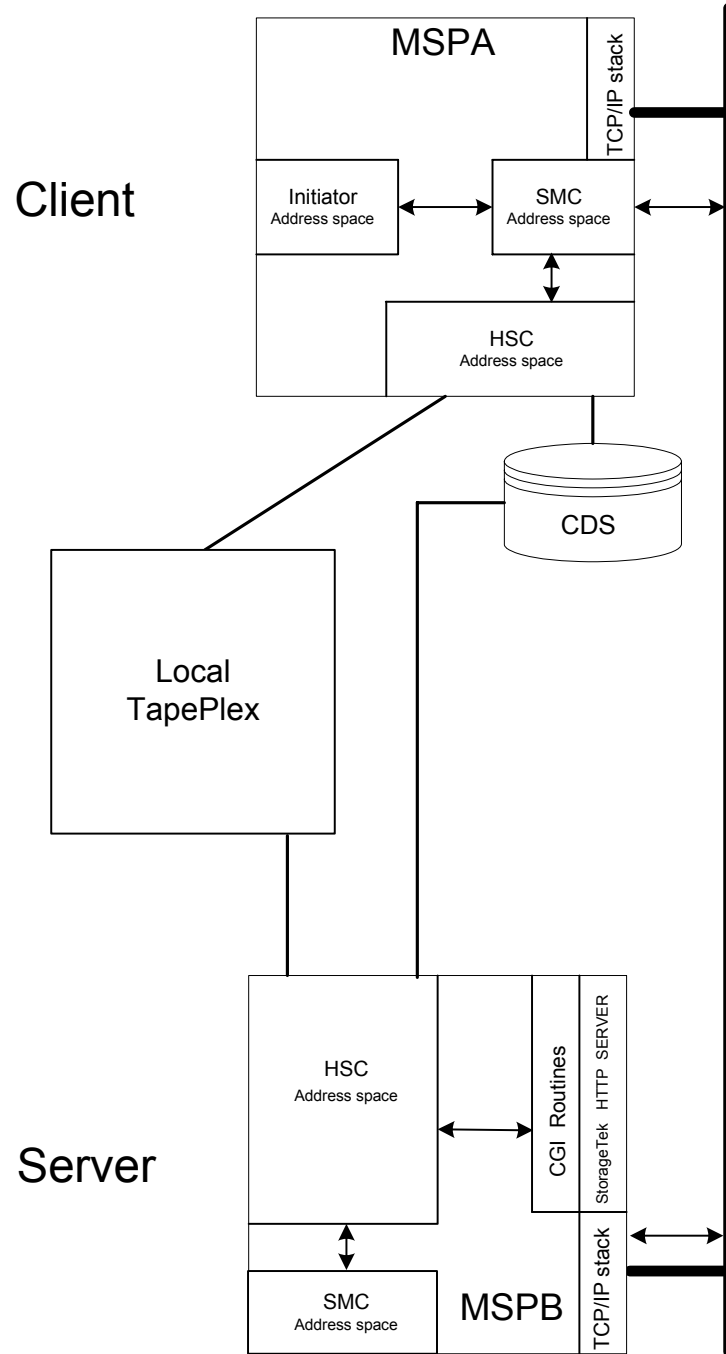

FIGURE 2-3 SMC and a Single HSC TapePlex with One Local and One Remote (alternate) Path

The following example illustrates the TAPEPLEX and SERVer commands for the SMC on MSPA:

```
TAPEPLEX NAME (PLEX1) LOCSUBSYS (HSC)
SERVER NAME (REMPATH) TAPEPLEX (PLEX1) HOST (MSPB)
```

In this scenario, if the HSC is active on host MSPA, the SMC communicates with the local HSC as described in Scenario 1. If the HSC on MSPA is inactive, the SMC on MSPA communicates with the remote HSC on MSPB as described in Scenario 2.

In this scenario, only the local TapePlex is defined on MSPB:

```
TAPEPLEX NAME (PLEX1) LOCSUB (HSC)
```

Primary And Alternate Path Selection Hierarchy To A Single TapePlex With A Local Path

The path utilized by the SMC in this scenario is dependent upon the following factors:

- Whenever a local path is available to a TapePlex, the SMC attempts to use it.
- If a local path to a TapePlex is not enabled, or the local HSC is inactive, the SMC attempts to communicate with the first defined remote server path. Once successful communication is established for a remote server, it becomes the active path. All subsequent requests use the active path unless the local path becomes active or the remote server path becomes unavailable.
- If a remote server path becomes unavailable, the SMC attempts to use the next available server in the order the SERVer commands were entered.

In this example, when HSC is active on host MSPA, the server path defined to MSPB is not used. However, if the HSC on MSPA becomes unavailable, the SMC attempts to send its requests to the TapePlex using the REMPATH server definition. When the HSC on MSPA becomes active again, the SMC automatically adjusts to use the HSC on MSPA.

It is possible to configure an HTTP server to run on MSPA to allow MSPA to act as a backup library server to MSPB, just as MSPB is acting as a backup library server to MSPA. This scenario is described in [“Scenario 4: SMC and a Single HSC TapePlex with Multiple Remote Server Paths”](#) on page 40.

Note – See [“Client/Server Drive Address Mapping”](#) on page 46 for additional requirements if different drive addresses are defined between client and server hosts.

Scenario 4: SMC and a Single HSC TapePlex with Multiple Remote Server Paths

In this scenario, the SMC runs on a host with no local HSC, but with multiple paths to a remote HSC, as illustrated in the following figure:

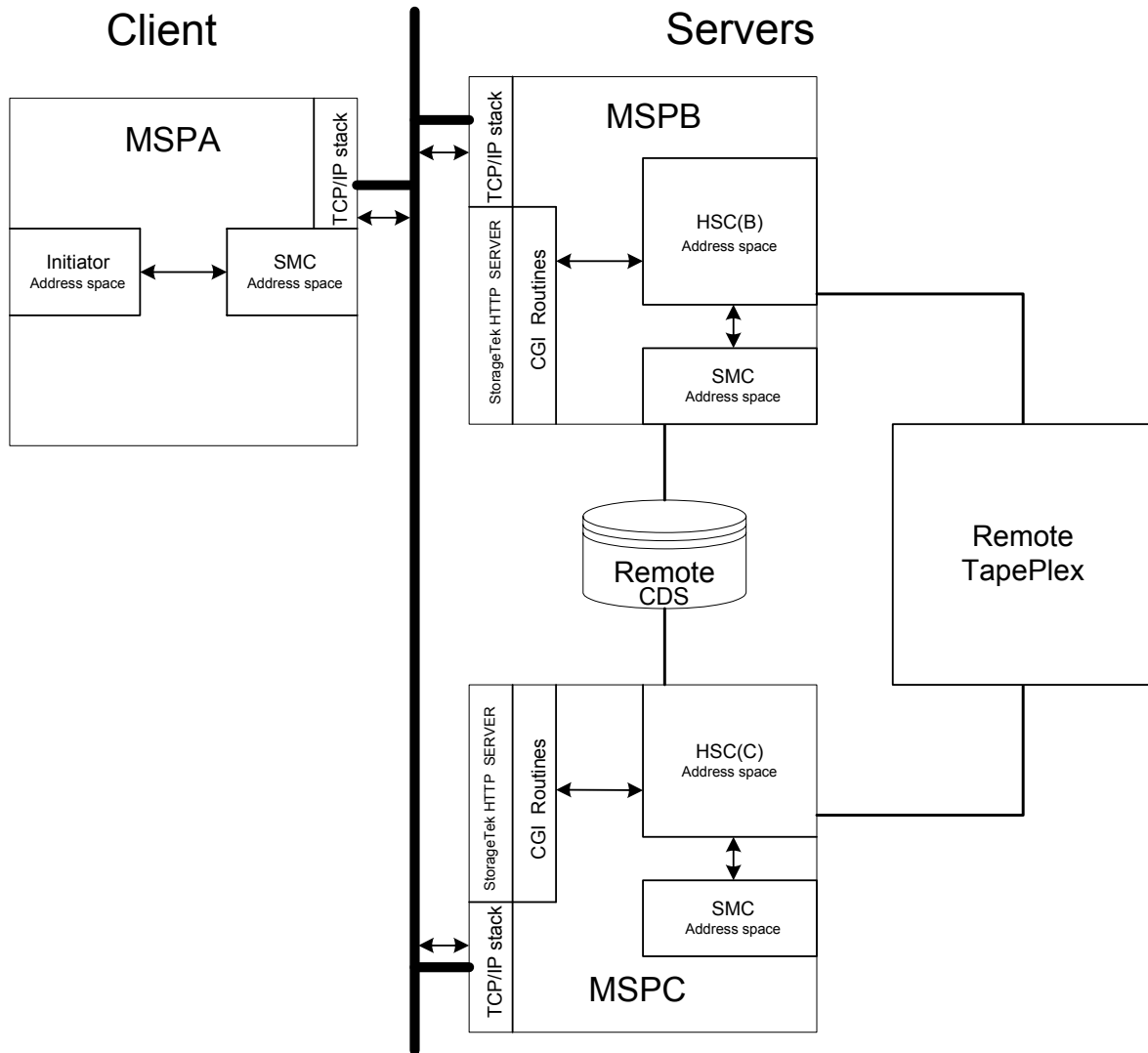

FIGURE 2-4 SMC and a Single HSC TapePlex with Multiple Remote Server Paths

The following example illustrates the TAPEPlex and SERVer commands for the SMC on MSPA:

```
TAPEPLEX NAME ( PLEX1 )
SERVER NAME (REMPATH1) TAPEPLEX ( PLEX1 ) HOST (MSPB)
SERVER NAME (REMPATH2) TAPEPLEX ( PLEX1 ) HOST (MSPC)
```

Requests originating in an Initiator Address Space on MSPA are intercepted by the SMC Address Space on MSPA. The SMC on MSPA sends requests for volume and drive data, and mount requests to the server on MSPB or MSPC.

The SMC attempts to communicate with the first defined server (MSPB). If this attempt fails, the SMC attempts to communicate with MSPC. Once successful communication with MSPC is established, the active path is not changed even if the server on MSPB becomes available. Either of the following methods can be used to change the active path from MSPC to MSPB:

- Disable the REMPATH2 server using the following command:

```
SERVER NAME (REMPATH2) DISABLE
```

The SMC automatically attempts to communicate with the first server in the list (REMPATH1).

- Issue the RESYNChronize REStart command. See [“RESYNChronize Command” on page 132](#) for more information.

On MSPB and MSPC, the SMC may operate only with the local HSC, or may use the communications facility to provide a backup, as shown:

MSPB:

```
TAPEPLEX NAME ( PLEX1 ) LOCSUBSYS (HSC)
SERVER NAME (REMPATH) TAPEPLEX ( PLEX1 ) HOST (MSPC)
```

MSPC:

```
TAPEPLEX NAME ( PLEX1 ) LOCSUBSYS (HSC)
SERVER NAME (REMPATH) TAPEPLEX ( PLEX1 ) HOST (MSPB)
```

The above TAPEPlex and SERVer commands allow MSPB to act as the backup library server to MSPC, and MSPC to act as the backup library server to MSPB.

See [“SMC Drive Type Information Synchronization” on page 48](#) for information about how the SMC acquires drive type information from the HSC.

Scenario 5: SMC with Two TapePlexes; One Local and One Remote

In this scenario, the SMC can coordinate allocation and mount requests among multiple TapePlexes as illustrated in the following figure.

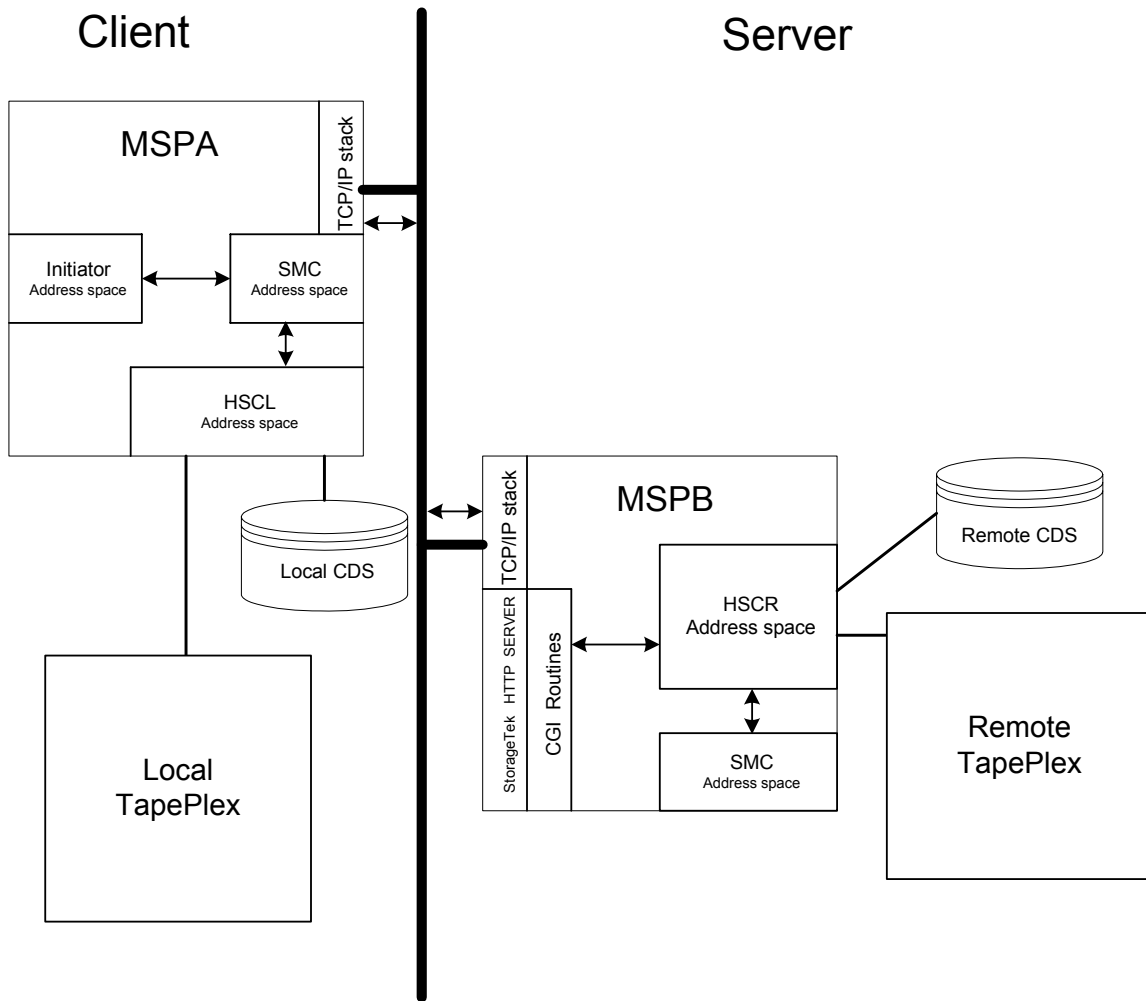

FIGURE 2-5 SMC with Two TapePlexes; One Local and One Remote

In this scenario, assume there are two separate TapePlexes, each defined by a different CDS. The SMC can communicate directly with the remote HSC using the StorageTek HTTP server.

Allocation and mount requests originating in an Initiator Address Space on MSPA are intercepted by the SMC on MSPA. These requests are then sent to either the local HSCL executing on the same host, or to the remote HSCR executing on the remote host MSPB.

The following example illustrates the TAPEPLEX and SERVER commands for the SMC on MSPA:

```
TAPEPLEX NAME (LOCPLEX) LOCSUBSYS (HSCL)
TAPEPLEX NAME (REMPLEX)
SERVER NAME (REMPATH) TAPEPLEX (REMPLEX) HOST (MSPB)
```

TAPEPLEX commands are required to define both the local and remote TapePlexes.

See [“SMC TapePlex Selection” on page 52](#) for information on how the SMC selects among multiple TapePlexes to determine an “owner” for each allocation request (i.e., each DD in a job step may have a different TapePlex owner).

Scenario 6: SMC with Two TapePlexes; One Local and One Remote with Multiple Paths

In this scenario, multiple TapePlexes are configured with multiple paths as illustrated in the following figure.

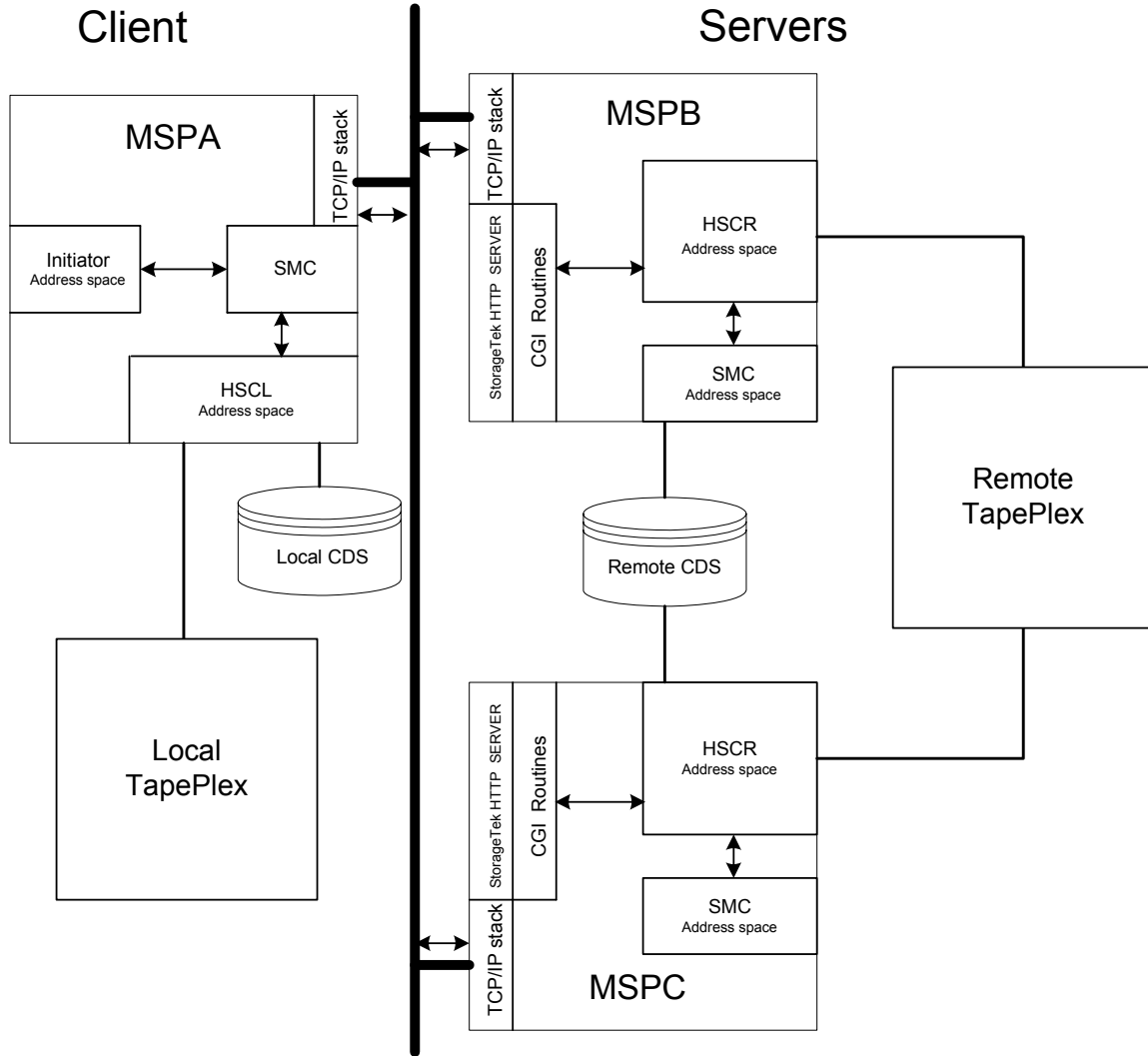

FIGURE 2-6 SMC with Two TapePlexes; One Local and One Remote with Multiple Paths

This scenario is a combination of scenarios 1 and 4. The following example illustrates the TAPEPLEX and SERVer commands for the SMC on MSPA:

```
TAPEPLEX NAME (LOCPLEX) LOCSUBSYS (HSCL)
TAPEPLEX NAME (REMPLEX)
SERVER NAME (REMPATH1) TAPEPLEX (REMPLEX) HOST (MSPB)
SERVER NAME (REMPATH2) TAPEPLEX (REMPLEX) HOST (MSPC)
```

Note – There are no predefined limits to the number of TapePlexes or server paths that a single SMC can have configured.

Client/Server Drive Address Mapping

SMC and HSC provide facilities that allow you to manage an environment in which drive addresses are different between client and server hosts. The table on the next page provides scenarios to help you determine whether client/server drive address mapping is required, and what actions and facilities are required.

TABLE 2-1 SMC Client/Server Drive Address Mapping Scenarios

Scenario	Drive Address Mapping - Action Required
<ul style="list-style-type: none"> ■ Client/server processing is not used. ■ Each MSP host runs a copy of HSC. 	None.
<ul style="list-style-type: none"> ■ Client/server processing is used. ■ Device addresses are identically defined for all hosts participating in a single client/server network. 	None.
<ul style="list-style-type: none"> ■ Client/server processing is used. ■ Device addresses are identically defined for all hosts in a single client/server network, but not all devices are defined to all hosts. 	Drive address mapping is not required. However, you must use the HSC SET SLIDRIVS utility to define all drive addresses on hosts that will be used as servers, even if the devices are not defined to the host. Refer to the <i>HSC System Programmer's Guide</i> for more information about the SET SLIDRIVS utility.
<ul style="list-style-type: none"> ■ Client/server processing is used. ■ Device addresses are identically defined to all HSC hosts, but one or more SMC client-only hosts use a different set of addresses for the same device. 	Use the SMC DRIVemap operator command to map the SMC client host addresses to the HSC host addresses. SMC performs the necessary address translations in influencing allocations and requesting mounts from the server. See “DRIVemap Command” on page 106 for more information.
<ul style="list-style-type: none"> ■ Client/server processing is used. ■ Two MSP hosts (MSP1 and MSP2), both running HSC and SMC. ■ One MSP host (MSP3) running only SMC but defined as communicating to <i>either</i> of the two hosts as a server. ■ Device addresses are defined differently among all three hosts. For example: <ul style="list-style-type: none"> ■ MSP1 (AA0-AAF) ■ MSP2 (BA0-BAF) ■ MSP3 (CA0-CAF) 	<ol style="list-style-type: none"> 1. Since the SMC on MSP3 can communicate with either the MSP1 or MSP2 host for a particular mount event, you must use the HSC SET utility, SET DRVHOST, to designate one of these hosts as the “drive host master.” For example, MSP1 (AA0-AAF). Once the drive host master is specified in the HSC CDS, the addresses associated with that host master (AA0-AAF) are used by both MSP1 and MSP2 when communicating with the SMC. If desired, you can add a dummy host ID to be the HSC DRVHOST, and use nonexistent drive addresses to map to client addresses. For example, use the HSC SET NEWHOST utility to define hostname DRVDUMMY and define the device range as 000-00F. Refer to the <i>HSC System Programmer's Guide</i> for more information about the HSC SET DRVHOST utility and HSC SET NEWHOST utility. 2. Use the SMC DRIVemap operator command on clients MSP2 and MSP3 to map drive addresses BA0-BAF and CA0-CAF to the server addresses AA0-AAF. See “DRIVemap Command” on page 106 for more information.

SMC Drive Type Information Synchronization

The SMC acquires drive type information from the HSC library control system using configuration queries sent from the SMC to each defined TapePlex. For HSC subsystems, drive configuration changes are automatically recognized by the SMC for both local and remote systems.

Specifying Drive Type Information Using SMC UNITAttr Commands

The SMC UNITAttr command allows you to augment or override information returned from NCS library control system configuration queries as required by the local host tape device configuration. Specifically, the UNITAttr command allows you to do the following:

- Set MODEL=IGNORE for device addresses not available for this host.
- Specify model types for nonlibrary devices on this host.
- Specify NOTAPEPLEX for a nonlibrary device address or range on this host, that are TapePlex owned devices on other hosts.
- Specify TapePlex ownership for a device address or range that is defined to multiple TapePlexes, but for this host the attached devices belong to the specified TapePlex.
- Specify TapePlex ownership and model for devices that may be referenced by a mount after the SMC is started, but before the TapePlex is initialized.

Note – UNITAttr commands are not required, and should only be issued under the conditions described in this section.

Specifying SMC UNITAttr Commands for Inaccessible Devices

To define devices that are represented by a UCB, but are not accessible from this host, issue an SMC UNITAttr command for each inaccessible device as follows:

```
UNITATTR ADDR(ccuu) MODEL(IGNORE)
```

UNITAttr MOdel(IGNORE) processing remains unchanged from previous releases. As a result, SMC does not include the device in any of its processing.

Specifying SMC UNITAttr Commands for Nonlibrary Devices

To define nonlibrary device types on this host, issue an SMC UNITAttr command for each nonlibrary device as follows:

```
UNITATTR ADDR(ccuu) MODEL(model)
```

A nonlibrary device is a StorageTek device that requires additional model information to be defined in order to differentiate it from other nonlibrary devices with similar UCB characteristics.

Specifying SMC UNITAttr Commands for Nonlibrary Devices with the Same Address as a TapePlex-Owned Device

If a device address for your host overlaps with a device address for a TapePlex owned device, and the TapePlex owned device is inaccessible from this host, issue an SMC UNITAttr command specifying the NOTAPEPLEX parameter as follows:

```
UNITATTR ADDR(ccuu) MODEL(model) NOTAPEPLEX
```

As a result, if a TapePlex such as HSC claims ownership via data returned from a configuration query, NOTAPEPLEX overrides the TapePlex. The configuration information is ignored and the device remains a nonlibrary device.

If you fail to specify NOTAPEPLEX, the TapePlex configuration information overrides the UNITAttr specified without the NOTAPEPLEX parameter, and the device definition changes from a nonlibrary to TapePlex owned device.

Specifying SMC UNITAttr Commands for TapePlex-Owned Devices with the Same Address as Another TapePlex-Owned Device

If your configuration includes multiple TapePlexes with overlapping device addresses or ranges, and both TapePlexes are defined to the SMC, enter a UNITAttr command with the TAPEPlex parameter to establish which TapePlex owns the specified device or range on this host. Enter a UNITAttr command for each of the duplicate drive addresses as follows:

```
UNITATTR ADDR(ccuu) MODEL(model) TAPEPLEX(name)
```

Example

Assume:

- Host MSPA includes two TapePlexes, HSC1 and HSC2.
- HSC1 includes a 9840 device range 2900-2903.
- HSC2 includes a 4480 device range 2900-2903.
- However, on MSPA, devices 2900-2903 are attached to HSC1. MSPA has no connection to the HSC2 device range.

Given this scenario, issue an SMC UNITATTR command as follows:

```
UNITATTR ADDR(2900-2903) MODEL(9840) TAPEPLEX(HSC1)
```

This command directs the SMC to ignore any configuration information for the specified devices from any TapePlex other than the specified TapePlex.

Note – If MSPA recognized address range 2900-2903 defined to HSC2 as a different address range (e.g. 4900-4903), MSPA would use the SET DRVHOST facilities (see page [46](#)) to define address range 2900-2903 on HSC2 as address range 4900-4903 for any client configuration queries.

Specifying SMC UNITAttr Commands for Devices in TapePlexes that are Initialized After the SMC

To define TapePlex owned devices when tape jobs are executed after the SMC starts but before the TapePlex is initialized, enter an SMC UNITAttr command for all TapePlex owned devices as follows:

```
UNITATTR ADDR(2900-2903) MODEL(9840) TAPEPLEX(HSC1)
...
UNITATTR ADDR(9000-903F) MODEL(VIRTUAL) TAPEPLEX(HSC1)
```

This directs the SMC to keep track of any tape policy for pending mounts, including VTCS MGMTCLAS.

SMC TapePlex Selection

When the SMC intercepts a specific or scratch allocation request, it selects an owning TapePlex to service the request. The following criteria are evaluated by the SMC in the order shown to determine which TapePlex controls the allocation request:

1. TapePlexes are interrogated in the order they are defined. If TAPEPlex commands are defined to the SMC, the order of the TAPEPlex commands is used. If TAPEPlex commands are not defined to the SMC, the order in the MSP SSCVT table is used.
2. If the Eligible Device List (EDL) for the request does not contain drives owned by a specific TapePlex, that TapePlex cannot own the request.
3. If an applicable SMC POLicy requests a specific TapePlex, it is selected as the request owner.
4. If the TAPEREQ or SMC POLicy esoteric contains only drives in a single TapePlex, it is selected as the request owner.
5. If a user exit explicitly selects a subsystem name or TapePlex name that is active, that TapePlex is the owner.
6. If the requested specific volume serial is specified in a TAPEREQ statement, the POLicy associated with the TAPEREQ determines the owner.
7. If a specific requested volume is found in a TapePlex, that TapePlex is considered the owner unless overridden by explicit esoteric or TapePlex selection. If the volume is not found in a TapePlex, but that TapePlex contains a VOLATTR for that volume, then the TapePlex is considered the owner if the specific volume is not found in any other TapePlex.
8. If a TapePlex indicates that it has scratch volumes for the request, it is considered the owner unless overridden by explicit esoteric or TapePlex selection. If the TapePlex does not have scratch volumes for the request, but the specified subpool name is known to the TapePlex, then the TapePlex will be considered the owner if scratch volumes are not found in any other TapePlex.

The preferred way to select a TapePlex owner from among multiple libraries is to specify a TapePlex name using the TAPEPlex parameter on the SMC POLicy command. Alternatively, TAPEREQ or POLicy esoteric, or user exit esoteric or TapePlex name can be used.

Note – Only a single version of an allocation user exit is executed, regardless of the number of TapePlexes defined. Therefore, user exit return codes such as “USE LIBRARY DRIVES”, “USE VIRTUAL DRIVES”, etc. are **not** used to determine a request owner, nor does the user exit return code of “USE NONLIBRARY DRIVES” result in the selection of a “different” TapePlex.

Starting the SMC

Overview

The SMC manages all interfaces with MSP for allocation and message handling, and therefore must be started as a task on every MSP host where tape processing occurs.

The SMC calls on HSC for volume and drive information. Therefore, HSC can be active on the same host, or HSC can be active on another host with the StorageTek HTTP server.

HSC can be initialized before the SMC without producing error messages. However, an SMC subsystem must be active to influence tape allocations and intercept MSP messages.

SMC startup requires the following tasks:

- Creating the SMC START procedure
- Executing the SMC START procedure

Note –

- Refer to the *NCS Installation Guide* for SMC installation procedures.
 - See [Chapter 12, “Using the StorageTek HTTP Server”](#) for information about starting the StorageTek HTTP server.
-

Creating the SMC START Procedure

An SMC START procedure must be created in the procedure library of the host system. The MSP START command invokes this catalogued procedure, thus activating the SMC with the specified startup parameter settings.

The following figure provides a sample SMC START procedure:

```
//yourprocname  PROC PRM='WARM'
//*
//* Run LOADHOST to initialize the IP environment for
//*   SMC-HTTP IP communications
//*
//stepname EXEC PGM=LOADHOST
//STEPLIB DD DISP=SHR,DSN=your.ncs.smc6200.smlink
//STKHSTDF DD DISP=SHR,DSN=your.host.ip.network.definitions
//STKPRTDF DD DISP=SHR,DSN=your.host.appl.definitions
//STKIFCDF DD DISP=SHR,DSN=your.host.ip.init.definition
//STKIFIDF DD DISP=SHR,DSN=your.host.osa.definition
//STKOWNDF DD DISP=SHR,DSN=your.host.name
//SYSPRINT DD SYSOUT=*
//STDOUT DD SYSOUT=*
//STDERR DD SYSOUT=*
//*
//stepname EXEC PGM=SMCBINT,REGION=4M,TIME=1440,
// PARM='&PRM'
//*
//STEPLIB DD DISP=SHR,DSN=your.ncs.smc6200.smlink
// DD DISP=SHR,DSN=your.ncs.exitlib
// DD DISP=SHR,DSN=your.ncs.sos6200.slslink
// DD DISP=SHR,DSN=your.ncs.sws6200.swslink
//*
//SMCPARMS DD DISP=SHR,DSN=parmlib_name(parm_member_name)
//*
//SMCCMDS DD DISP=SHR,DSN=cmdlib_name(cmd_member_name)
```

FIGURE 3-1 Sample SMC START Procedure

Note –

- The first four characters of *yourprocname* specify the SMC subsystem name (unless the SSYS startup parameter is specified). The recommended value is SMC*x*, where *x* is any valid jobname character.
- Due to product dependencies, the HSC load library (SLSLINK) is required in the STEPLIB concatenation. Additionally, the VTCS load library (SWSLINK) is required in the STEPLIB concatenation to support the ability to route VTCS commands from the SMC to an HSC TapePlex on the same host (using the SMC Route command).
- The SMCPARMS and SMCCMDS DD statements are optional. Both statements are processed during initialization. The SMCCMDS data set may be re-processed during execution. See [Chapter 7, “Commands and Control Statements”](#) for information about SMC commands that may be specified in either of these data sets. It is recommended that you include **only** those commands required to be in the SMCPARMS data set (e.g. CMDDEF and USERMSG) in SMCPARMS. Place all remaining startup parameters in SMCCMDS.

Review the following commands or control statements to determine whether they should be included in your SMCCMDS data set:

- ALLOCDef
 - DRIVemap
 - MOUNTDef
 - POLicy
 - READ
 - RESYNChronize
 - SERVer
 - TAPEPlex
 - TCPip
 - TREQDef
 - UEXit
 - UNITAttr
-
- Use of the POLicy command requires that TAPEPlex and SERVer commands be processed before POLicy commands (which must be processed before TAPEREQ control statements).
 - TIME=1440 must be coded to ensure that the SMC does not time out and terminate.
-

SMC EXEC Statement

The EXEC statement is used to define SMC startup parameter settings.

EXEC Statement Syntax

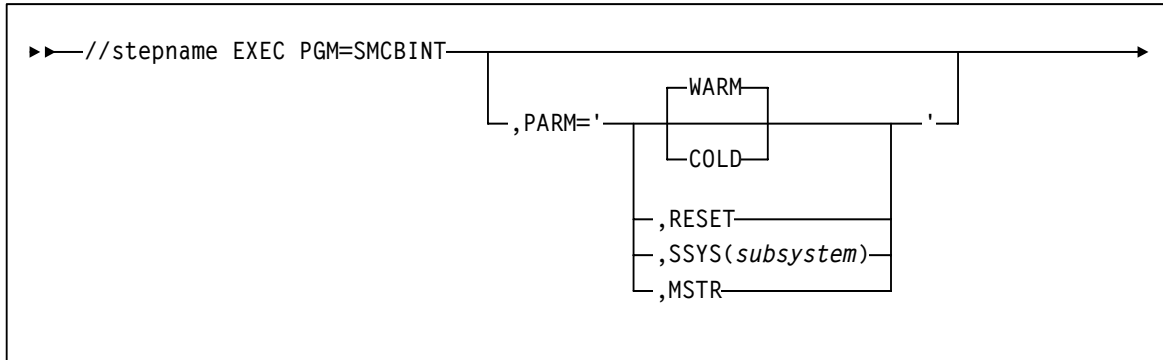

EXEC Statement Parameters

PARM=

defines the list of parameters passed to the SMC initialization routine.

Note – Execution parameters must be separated with commas. Separating parameters with blanks results in a syntax error.

WARM

specifies that the SMC main control block is not rebuilt. This is the default setting for normal operation.

COLD

specifies that all SMC control blocks are rebuilt. This parameter is mutually exclusive with WARM.

Caution – Do **not** use this parameter unless the SMC has terminated abnormally and cannot be restarted.

SSYS

specifies a *subsystem* ID that is different from the first four characters of the SMC START procedure. The SMC searches for this subsystem ID during initialization. *subsystem* must be one to four characters in length.

RESET

specifies that the active subsystem status flag in the MSP Subsystem Communications Vector Table (SSCVT) for the SMC is reset. This parameter may correct a situation in which the SMC was terminated abnormally. It can be specified with WARM or COLD.

Note – Using this parameter when an SMC subsystem is active and functional causes unpredictable results.

MSTR

specifies that the SMC start under the MSTR subsystem instead of under JES.

When specifying this parameter, you **must** also perform **one** of the following actions:

- Start the SMC subsystem using SUB=MSTR on the MSP Start command.
- Add the SMC subsystem to the SUBSYSxx subsystem table using the keyword format.

Note – If you wish to run the SMC under the master MSP subsystem, the PROCLIB containing the SMC START procedure must be present in the PROCLIB concatenation for the master address space. This concatenation is defined in SYS1.PARMLIB(MSTJCLxx), under DD KDJPSI.

Executing the SMC START Procedure

The MSP START command is used to initialize the SMC software. When this command is issued, the SMC subsystem initialization routine is invoked. This routine determines what parameters are in effect, performs any cleanup necessary, and begins normal processing.

Parameters associated with PARM= on the EXEC statement of the SMC Start Procedure can also be supplied via PARM= on the MSP START command. The PARM= specification on the MSP START command overrides the PARM= specification in the SMC Start Procedure. See [“EXEC Statement Parameters” on page 56](#) for parameter descriptions.

MSP START Command Syntax

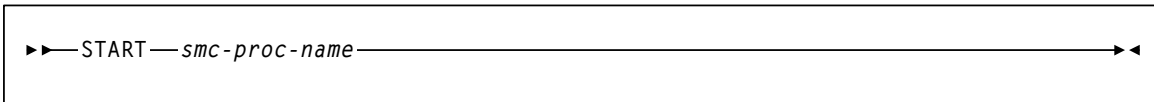

MSP START Command Parameters

START or **S**

initiates the MSP START command

smc-proc-name

indicates the name of the SMC START procedure member.

Policy

Overview

Two primary functions of the SMC are to influence MSP allocation to select devices compatible with tape volumes and to intercept MSP messages for tape mounts and dismounts to automate these operations for library and virtual drives.

For specific volumes, SMC allocation is primarily based on volume media and location. For scratch volumes, SMC allocation and mount processing are primarily based on user policies. Policies to control scratch allocation and mount processing may be selected in one or more of the following ways:

- SMC TAPEREQ statements
- User exits

The order listed is the preference order in SMC. That is, a policy specified via TAPEREQ has preference over a policy specified in a user exit.

The SMC POLIcy Command

SMC 6.2 introduces a new method for specifying policies for tape allocation and mount requests. The SMC POLIcy command allows you to create named policy objects (SMC policies) that contain all of the tape policy attributes associated with an allocation or mount event, including MEDia, RECtech or MODel, SUBPool, ESOTeric, VTCS MGMTclas, and TAPEPlex.

The POLIcy command can be used in conjunction with TAPEREQ statements to associate a named policy with allocation and mount requests. The SMC TAPEREQ control statement is enhanced to support the new policy specification. This enhancement is described in this chapter.

SMC policies are normally defined in a single data set or PDS member which is loaded at SMC startup using the SMC READ command. Additionally, the POLICY command may be issued at any time to add a new policy or replace the contents of an existing policy.

In the following sample SMCCMDS data set, the READ command loads the POLMEM data set containing the SMC policies:

```
ALLOCDEF POLICY(ON) ZEROSCR(ON,INSIDE)
MSGDEF CASE(MIXED)
TAPEPLEX NAME(HSCPLEX) LOCSUB(HSC0)
READ DSN('CNTL.PDS(POLMEM)')
TREQDEF DSN('CNTL.PDS(TREQMEM)')
```

FIGURE 4-1 Sample SMCCMDS Data Set

Note –

- POLICY commands must be processed **before** the TREQDEF command if any TAPEREQ statements reference policies by name.
 - If any POLICY command references a TAPEPLEX, the TapePlex name must be defined using a TAPEPLEX command **before** the POLICY command is processed.
 - See [“POLICY Command” on page 123](#) for more information about the SMC POLICY command.
 - See [Chapter 7, “Commands and Control Statements”](#) for detailed information about the TAPEREQ control statement and SMSDef operator command.
 - Existing policy specifications using non-policy TAPEREQ parameters and user exits are still supported. However, this support will end in a future release.
-

SMC Policy and the TAPEREQ Control Statement

SMC TAPEREQ control statements are used to specify tape request attributes, including tape policy. For each allocation or mount request, SMC evaluates TAPEREQ statements to determine the tape policies to be applied, for example, esoteric name, subpool, media and management class. These policy attributes are selected according to a set of selection criteria, for example, job step, step name, and data set name.

TAPEREQ control statements reside in a definition data set specified by the TREQDEF operator command. TAPEREQ statements must be placed in this definition data set; they **cannot** be issued as operator commands.

SMC 6.2 allows TAPEREQ control statements to reference SMC policy objects. The optional TAPEREQ POLICY parameter directs the SMC to reference an associated SMC policy defined by an SMC POLICY command.

Note – POLicy commands must be processed **before** the TREQDEF command if any TAPEREQ statements reference policies by name. See [FIGURE 4-1 on page 60](#).

The POLicy parameter is mutually exclusive with all other TAPEREQ output parameters or tape policy attributes, including MEDia, RECTech, MODel, SUBpool, ESOTeric, and MGMTclas. When the POLicy parameter is specified, the SMC locates the associated SMC policy definition and uses it to determine **all** policy information for the allocation or mount event. This enhancement is designed to make TAPEREQ behavior more predictable. Use of the SMC POLicy parameter eliminates a condition where multiple tape policy attributes are selected from multiple TAPEREQ control statements.

If the POLicy parameter is not specified on the TAPEREQ control statement, SMC reverts to its previous behavior and performs a separate lookup for each required parameter for an allocation or mount event.

If you are migrating from a previous SMC release, it is recommended that you convert your existing TAPEREQ statements to use the new SMC POLicy command facility. A TAPEREQ conversion script, included in the SMC SAMPLIB, is provided to assist you in this process. See [Appendix C, “TAPEREQ Conversion Script \(POLCVT02\)”](#) for more information. This appendix includes an example of output generated from existing TAPEREQ statements.

Note –

- Existing policy specifications using non-policy TAPEREQ parameters and user exits are still supported. However, this support will end in a future release.
- If a tape policy attribute is not present in the named policy object, then no additional policy is applied to that tape policy attribute and no further TAPEREQ lookups are performed.
- If a TAPEREQ statement specifying the POLicy parameter matches an allocation or mount request, **no** parameters supplied from a user exit are honored. Message SMC0197 is issued to indicate user exit supplied parameters that are ignored. For example, suppose the following POLicy is applied to an allocation or mount event:

```
POLICY NAME(POL1) MEDIA(STK1R) TAPEPLEX(HSCPLEX)
```

In addition, suppose that a scratch user exit (UX02) supplies a subpool name or number. The user exit subpool is **not** honored and the allocation is performed using the default subpool (subpool 0).

SMC Policy and Esoteric Preferencing

The SMC POLicy command allows you to preference devices during the allocation process. The ESOTeric parameter can specify a list containing a maximum of eight esoterics. During drive exclusion, devices in any of the listed esoterics are included. During drive prioritization, devices are ordered according to their position in the esoteric list. This feature allows you to do the following:

- Prefer faster or slower models of equivalent drives.
- Prefer a certain device type (e.g. 9940) if drives are available but select an alternative device type if preferred drives are busy.

By default, SMC prefers drives based on the following criteria in order:

1. specific volume LSM location
2. esoteric list
3. LSM scratch count.

The relative weight can be changed using the POLicy PREFer parameter. See [“POLicy Command” on page 123](#) for more information.

Specifying TAPEREQ and Policy by Volume Serial

Using a combination of TAPEREQ statements and POLICY commands, SMC allows you to specify allocation policy based on specific volume serial numbers. In some cases this feature may allow you to replace HSC nonlibrary VOLATTRs with SMC TAPEREQ and POLICY commands.

Note – The VOLSER keyword on a TAPEREQ statement is allowed only if the POLICY keyword is also specified and references a previously defined SMC policy with the keyword VOLTYPE(SPECIFIC).

Using policy associated with volume serials allows you to:

- Define different volume characteristics for the same volume serial for different clients.

For example, suppose that volsr AAAAAA exists in the TapePlex on an HSC server with a media of STK1R, but on a specific client, volume AAAAAA is a nonlibrary standard cartridge. The following combination of POLICY commands and TAPEREQ statements allows the SMC to bypass the volume lookup for volume AAAAAA and use the specified policy information:

```
POLICY NAME (MANVOL) VOLTYPE (SPECIFIC) MEDIA (STANDARD) NOTAPEPLEX
```

```
TAPEREQ VOLSER (AAAAAA) POLICY (MANVOL)
```

- Limit volume lookup to a single TapePlex based on volume serial.

For example, suppose that the SMC on a client host has two defined TapePlexes, PLEX1 and PLEX2, which contain overlapping volume serial ranges (AAA000-AAA999 and BBB000-BBB999). By default, SMC queries the TapePlexes in the order in which they are defined and uses information from the first TapePlex that recognizes the volume serial. The following combination of POLICY commands and TAPEREQ statements allows the SMC to choose the correct version of the volume for the client host:

```
POLICY NAME (PLEX1VOL) VOLTYPE (SPECIFIC) TAPEPLEX (PLEX1)
```

```
POLICY NAME (PLEX2VOL) VOLTYPE (SPECIFIC) TAPEPLEX (PLEX2)
```

```
TAPEREQ VOLSER (AAA000-AAA999) POLICY (PLEX1VOL)
```

```
TAPEREQ VOLSER (BBB000-BBB999) POLICY (PLEX2VOL)
```

- Direct allocation of volumes outside the library into a specific library.

The following combination of POLICY commands and TAPEREQs causes SMC to bypass library volume lookup and allocate the selected nonlibrary volumes to library drives compatible with standard cartridges:

```
POLICY NAME (INLIB) VOLTYPE (SPECIFIC) ESOTERIC (LIB1ESOT)
```

```
MEDIA (STANDARD) NOTAPEPLEX
```

```
TAPEREQ VOLSER (AAA000-AAA999) POLICY (INLIB)
```

Example

The following example illustrates the recommended method for specifying SMC Policy commands, TREQDEF commands, and TAPEREQ control statements.

1. Include the following entry in the SMC Start procedure:

```
//SMCCMDS DD DSN=MY.PARMLIB(MYSMCCMD),DISP=SHR
```

2. Include the following entries in SMCCMDS member MYSMCCMD:

```
READ DSN('MY.PARMLIB(SMCPOL)')
TREQDEF DSN('MY.PARMLIB(SMCTREQ)')
```

Note – If TAPEREQ statements include POLICY parameters, the POLICY commands **must** be processed **before** the TREQDEF command since the policy name in the TAPEREQ statement is validated against the defined policy definitions.

3. Add the SMC POLICY commands to member SMCPOL, for example:

```
POLICY NAME(POL1) SUBPOOL(SP1) MEDIA(STK1R) RECTECH(STK1RC)
TAPEPLEX(HSC)
```

```
POLICY NAME(POL2) SUBPOOL(SP2) MEDIA(VIRTUAL) MGMTCLAS(ABC)
```

4. Modify TAPEREQ control statements in member SMCTREQ to point to the named policies, for example:

```
TAPEREQ DSN(A.B.*) POLICY(POL1)
TAPEREQ DSN(A.C.*) POLICY(POL2)
```

These TAPEREQ statements point to the SMC policy names defined in Step 3.

Note – The HOST parameter on the SMC READ command may be used to specify different policy definitions for different hosts. For example:

```
READ DSN(MY.PARMLIB(PRODPOLS)) HOST=PROD
READ DSN(MY.PARMLIB(TESTPOLS)) HOST=TEST
```

If the host name is PROD, member PRODPOLS is loaded. If the host name is TEST, member TESTPOLS is loaded.

Allocation

Overview

A primary function of the SMC is to influence the operating system selection of tape drives during allocation to ensure that acceptable devices are selected in a StorageTek TapePlex and virtual environment. In addition, the SMC creates a preferred list of acceptable devices based on specific volume location, scratch load balancing, and user policies.

Generally, SMC allocation cannot add devices to the original list created from the job's JCL. It can only eliminate unacceptable devices and preference the remaining acceptable devices.

The SMC determines the list of drives acceptable for each tape allocation by applying a series of criteria (referred to as "exclusion levels") to the initial set of devices, removing those drives that do not meet the criteria. This process is referred to as **drive exclusion**.

If the SMC attempts to apply a particular exclusion criterion and as a result, all remaining eligible drives are excluded, messages SMC0045 and SMC0046 are displayed indicating that a particular exclusion criterion could not be applied. However, the exclusion process continues, with the SMC applying subsequent criteria if possible.

SMC allocation may intentionally cause a job to fail allocation when it appears that a mount to any of the drives in the available list would fail. For example, a volume with a media STK1R cannot be physically mounted on a 9490 drive, and a nonlabeled tape cannot be virtual.

Additionally, some customers may prefer to fail a job in allocation rather than use undesired scratch media or require a specific volume to be ejected and entered into a different ACS. The SMC ALLOCDEF (or ALLOCJOB) MINLVL parameter can be used to fail jobs in allocation, or conversely, to override the SMC default behavior of failing jobs in allocation.

- Setting MINLVL=0 specifies that the SMC should NEVER fail a job in allocation.
- The default MINLVL, 2, indicates that jobs should be failed in allocation only for incompatible media or virtual label type.

Customers may set MINLVL to higher values if desired. See [“SMC Drive Exclusion”](#) below for detailed information about SMC exclusion levels for specific and scratch volumes.

After all exclusion criteria have been applied, the remaining drives are arranged in order of their desirability based on policy, volume location or scratch count, and last mount time. This process is referred to as **drive prioritization**. During this process, the SMC also sets flags in MSP control blocks to indicate that the mount should be deferred until OPEN, unless a policy specifies that mounts should not be deferred.

Note – SMC allocation does not consider the status of the drives (e.g. offline, busy) when selecting drives eligible for an allocation request. If all SMC-selected drives are unavailable, the job enters allocation recovery.

SMC Drive Exclusion

The SMC drive exclusion process includes the following steps:

1. The SMC examines the initial list of eligible devices for each tape DD in each jobstep (or dynamic allocation), and gathers policy information from various sources, including a combination of SMC POLICY commands and TAPEREQ control statements, and user exits.
2. The SMC performs "volume lookup" by communicating with one or more TapePlexes, and gathering information about specific volume characteristics and location, as well as available scratch volumes. If the SMC is unable to obtain this information from a TapePlex, the ALLOCDef FAILnoinfo parameter may be used to control whether the job is allowed to fail in allocation or to proceed based only on available policies.
3. The SMC applies the information received from volume lookup and policies using an ordered set of levels, with the earliest (lowest numbered) levels applied first and least important levels applied later, e.g. level 2 is considered more important, and is applied before level 3, etc.

Whenever application of a particular exclusion would eliminate all drives, the SMC ignores the criterion and continues with the next exclusion level.

Note – See [Chapter 4, “Policy”](#) for a description of SMC Policy specification.

Allocation User Exits

If allocation user exits are specified using the SMC UEXIT command, these exits are executed prior to the drive exclusion process. Only one user exit may be specified for each type of allocation.

Allocation user exits include:

- UX02 - JES Scratch volume user exit
- UX08 - JES Specific volume user exit

The Scratch volume user exits are invoked prior to the volume lookup. Their policies, including esoteric and TapePlex name, may be used to influence which TapePlexes are queried by the SMC for available scratch volumes.

The Specific volume user exits are invoked after volume lookup and are passed the TapePlex name and the location where the volume resides, if the volume is found in a TapePlex. The exit may supply either an esoteric or a different TapePlex name to force the allocation to a different location than that determined by the volume lookup.

Note –

- It is recommended that you replace user exits with SMC POLICY and TAPEREQ statements whenever possible.
 - Refer to the *NCS User Exit Guide* for more information about the NCS allocation user exits.
-

Drive Exclusion - Specific Volumes

For a specific volume allocation, the SMC excludes drives in order from lowest exclusion level to highest based on the criteria in the following table. The lower the level number, the more important the exclusion criteria.

TABLE 5-1 Drive Exclusion Levels (Specific Request)

Level	Specific Volume Criteria	Keyword†
1	For non-labeled (NL) specific volume requests, exclude all virtual drives. Exclude all MODEL=IGNORE drives. Exclude drives incompatible with the volume media. Primary source: external volume label Secondary source: VOLATTR MEDIA parameter The volume media can be obtained from the volume label or from an HSC VOLATTR statement MEDIA parameter.	VIRTUALLABEL MEDRECTECH
2*	For virtual volumes only, exclude virtual drives that reside in an inaccessible VTSS or in a VTSS to which a migrated virtual volume cannot be recalled.	AVAILVTSS
3	Exclude drives based on the required recording technique. Source: VOLATTR RECTECH parameter or volume density (i.e. 9840A/B and 9840C).	VOLATTRRECTECH
4	Exclude drives based on user location policies. Primary source: POLICY or TAPEREQ ESOTERIC parameter. Secondary source: Specific volume user exit 08 or affinity separation exit 10 return codes.	USERPOLICY
5	Exclude drives based on the SMC ALLOCDEF EXTVOLESOT esoteric.	EXTVOLESOT
6	Exclude drives based on volume location type (i.e. library or nonlibrary).	LOCTYPE
7	Exclude drives based on the ACS location of the volume (for library volumes), and the resident VTSS for virtual volumes.	ACSORVTSS
8	Exclude drives based on the requested recording technique. Source: POLICY or TAPEREQ RECTECH parameter.	POLRECTECH

*Level 2 is the default minimum level.

†Keywords associated with each exclusion level are specified in the exclusion criteria displayed in message SMC0046.

Example

The following example illustrates how the SMC applies exclusion levels to influence the allocation of specific volumes.

JCL:

```
//DDNAME DD DSN=ABC.DEF,DISP=OLD
```

Policy specification:

```
POLICY NAME(POL1) VOLTYPE(SPECIFIC) ESOTERIC(A19840B,A19840A)
RECTECH(STK1RB)
```

```
TAPEREQ DSN(ABC.*) POLICY(POL1)
```

Volume lookup information:

- Specific volume VOL123
- SMC volume lookup indicates that VOL123 has a media type of STK1R single density in TapePlex HSCLIB ACS 0.

Allocation exclusion processing:

1. Starting at exclusion level 1, the SMC excludes all non-9840 devices (those not compatible with the volume media).
2. Level 2 has no effect.
3. The SMC does not exclude any devices at level 3 since there was no HSC VOLATTR to limit the volume to single density drives.
4. The SMC excludes all drives not in the esoteric A19840B or A19840A.
5. The SMC does not exclude any devices at level 5 because the volume is in the TapePlex.
6. The SMC excludes all nonlibrary drives, if any remain.
7. The SMC attempts to exclude all drives not in ACS 0. However, since the remaining devices at this point include only 9840 drives in ACS1 (based on the esoterics A19840B and A19840A), there are no drives remaining in the EDL after this exclusion.

The SMC then "backs up" to the EDL as it was prior to the level 7 exclusion and issues messages SMC0045/SMC0046 specifying ACSORVTSS as the conflicting criterion.

Only drives in esoterics A19840B and A19840A remain eligible, based on exclusion level 4.

8. Level 8 has no effect.

Allocation preference processing:

During drive prioritization, SMC assigns a higher preference value to drives in esoteric A19840B, and a lower preference value to drives in A19840A.

Drive Exclusion - Scratch Volumes

For a scratch volume allocation, the SMC excludes drives in order from lowest exclusion level to highest based on the criteria in Table 3. The lower the level number, the more important the exclusion criteria.

TABLE 5-2 Drive Exclusion Levels (Scratch Request)

Level	Scratch Volume Criteria	Keyword*
1	For nonlabeled (NL) scratch volume requests, exclude all virtual drives. Exclude all MODEL=IGNORE drives.	VIRTUALLABEL
2	For virtual volumes only, exclude virtual drives that reside in an inaccessible VTSS, and all drives in VTSSs that do not support the requested VTCS Management Class.	AVAILVTSS
3	Exclude drives based on the requested media. Primary source: POLicy or TAPEREQ MEDIA parameter. Secondary source: Scratch volume user exit 02 virtual media return code or virtual esoteric.	POLMEDIA
4	Exclude drives based on user location policies. Primary source: POLicy or TAPEREQ ESOTERIC parameter. Secondary source: Scratch volume user exit 02 or affinity separation exit 10 return codes.	USERPOLICY
5	Exclude drives based on the media of available scratch volumes in subpool. Primary source: POLicy or TAPEREQ SUBPOOL parameter. Secondary source: Scratch volume user exit 02 subpool name or number. Tertiary source: Scratch subpool 0 (default subpool), containing all real and virtual scratch tapes including those in named subpools.	SUBPOOL
6	Exclude library, nonlibrary, or virtual drives based on location of available library or virtual scratch volumes.	LOCTYPE
7	Exclude drives based on the SMC ALLOCDef command ZEROSCR parameter.	ZEROSCRATCH
8	Exclude drives based on the requested recording technique. Source: POLicy or TAPEREQ RECTECH parameter.	POLRECTECH

*Keywords associated with each exclusion level are specified in the exclusion criteria displayed in message SMC0046.

Example - Real Scratch Volume

The following example illustrates how the SMC applies the exclusion levels to influence the allocation of scratch volumes.

JCL:

```
//DDNAME DD DSN=DEF.GHI,DISP=NEW
```

Policy specification:

```
POLICY NAME(POL2) VOLTYPE(SCRATCH) SUBPOOL(SP1) MEDIA(ECART)
MODEL(9490)
```

```
TAPEREQ DSN(DEF.*) POLICY(POL2)
```

```
SMC ALLOCDEF ZEROSCR(ON)
```

Scratch user exit returns use SUBPOOL(SP2) and ESOTERIC(XYZ).

Volume lookup information:

SMC volume lookup reports that TapePlex HSCLIB has scratch volumes in subpool SP1.

Allocation exclusion processing:

1. Starting at exclusion level 1, the SMC excludes drives which have an SMC UNITATTR command specifying MODEL=IGNORE.
2. Level 2 has no effect.
3. The SMC excludes all devices that do not support a media ECART.
4. Because POLicy is specified, the user exit esoteric XYZ is ignored, and level 4 has no effect. Message SMC0197 is issued to indicate this.
5. The SMC excludes all drives not compatible with the scratch volumes in subpool SP1 (TAPEREQ policy overrides user exit policy).
6. The SMC excludes all nonlibrary drives.
7. If scratch volumes for SP1 exist only in a single ACS, the SMC excludes drives in other ACSs.
8. The SMC excludes all remaining drives that do not have a MODEL of 9490.

Example - Virtual Scratch Volume

The following example illustrates how the SMC applies the exclusion levels to influence the allocation of virtual scratch volumes.

JCL:

```
//DDNAME DD DSN=GHI.JKL,DISP=NEW
```

Policy specification:

```
POLICY NAME(POL3) VOLTYPE(SCRATCH) ESOTERIC(VTSS1) SUBPOOL(VIRT1)
MGMTCLAS(MGMT1)
```

```
TAPEREQ DSN(GHI.*) POLICY(POL3)
```

Volume lookup information:

SMC volume lookup returns a list of VTSSs eligible for scratch allocation. In this example the list returned is VTSS2 and VTSS3 based on online VTSSs with access to ACSs and RTD recording techniques compatible with MGMT1.

Allocation exclusion processing:

1. Starting at exclusion level 1, the SMC excludes drives which have an SMC UNITATTR command specifying MODEL=IGNORE.
2. The SMC excludes all virtual drives not in either VTSS2 or VTSS3.
3. The SMC excludes all non-virtual drives because the POLICY esoteric VTSS1 contains only virtual drives.
4. The SMC excludes all drives not in VTSS1.

Since VTSS1 is not one of those returned by HSC/VTCS, the SMC "backs out" the level 4 exclusion and issues messages SMC0045/SMC0046, but continues other processing. Only drives in VTSS2 and VTSS3 remain eligible, based on exclusion level 2.

In this example, the remaining exclusion levels have no effect.

Affinity Separation

Explicit unit affinity is an MSP facility that allows volumes associated with two separate JCL DD statements, or allocation requests, to be mounted serially on the same drive. A request for all generations of a GDG group (GDG ALL chain) can be considered as a GDGALL affinity.

The SMC makes no distinction between these two types of affinity. When processing an affinity chain, the drive exclusion process examines each allocation in the chain separately up to and including the minimum exclusion level. The chain is always separated when the minimum exclusion level processing results in lists of eligible drives, for two or more members of the chain, that do not contain common drives.

For example:

```
//DD1 DD UNIT=CART, DSN=MY . STK1R . DATASET, DISP=OLD
//DD2 DD UNIT=AFF=DD1, DSN=MY . LONGI . DATASET, DISP=OLD
```

DD1 specifies a data set on 9840 or T9840B media and DD2 specifies a data set on longitudinal media. Drive exclusion level 1 for specific volumes creates a list of eligible drives for each DD according to volume media required. The two lists do not contain a common drive. As a result, the SMC breaks the affinity chain between DD1 and DD2, and the two DD statements no longer represent one drive allocation but two separate allocation requests.

Affinity Head-Of-Chain

For SMC affinity chain processing, the head of the affinity chain containing only scratch or only specific volumes is the first DD statement in the chain. If an affinity chain contains both scratch and specific volumes, the first specific volume is treated as the head of chain.

User Policy Influence on Affinity Separation

After the minimum level of drive exclusion and affinity separation completes, user policy influences the remaining affinity separation decisions.

The ALLOCDef or ALLOCJob SEPLvl parameter can be used to indicate that affinity chains NOT be separated based on the exclusion levels described in this chapter. User exit 10 can also be used to control affinity separation. Refer to the *NCS User Exit Guide* for more information.

Drive Prioritization

SMC drive priority is assigned based on the following criteria:

- For specific volumes, drives in LSMs closest to the volume are preferred. The SMC sets equal priority value for drives that are located the same number of passthroughs away from the specific volume.
- For scratch volumes, drives in LSMs with the largest number of scratch volumes matching the policy-requested media and rectech are preferred.
- The POLICY ESOTERIC list causes drives to be preferred according to the order specified in the esoteric list.
- The POLICY PREFER parameter indicates the relative priority of LSM location (location for specific volumes), the esoteric list (esoteric for both scratch and specific volumes) and scratch count (count for scratch volumes) in determining the preference value of each device.
- The TAPEREQ DEVTPREF parameter causes drives with specific recording technique to be preferred.
- The TAPEREQ SCOPE parameter indicates the relative priority of LSM location and device type in determining the preference value of each device.

The following parameters, control statements, and user exits also influence drive priority:

- HSC ALLOC command parameters LOWSCR, LSMPREF, and SCRTECH
- Scratch user exit (HSC user exit 02)

After a final list of drives has been selected for allocation, the preference order of the eligible drives (after considering LSM and drive type preferencing) is selected based on a "last use" algorithm.

To reduce excessive wear on allocated drives, the SMC assigns drive preference values by rotation based on the "last mount time" for each drive. This value is examined for every drive in the final drive list. The drive that had the most recent mount is located, and the drive immediately following it in the list is selected as the most preferred for the current allocation.

Note – This algorithm does not apply to virtual drives.

Deferring Mounts

By default, the SMC defers all automated tape mounts. The SMC ALLOCDef command DEFER parameter can be set to override this default. For optimal performance, it is recommended that you use the default DEFER(ON). See [“ALLOCDef Command” on page 87](#) for more information about this parameter.

Note – Virtual mounts are always deferred.

SMC Allocation Exceptions

The SMC does not influence the following types of cartridge tape allocation:

- Demand allocation (i.e., request for a specific drive(s))

Note – The SMC does perform DEFER processing for demand allocation.

- Allocations excluded explicitly by entering the ALLOCJob command BYPASS parameter. See [“ALLOCJob Command” on page 92](#) for more information about this parameter.
- Allocations where the list of eligible devices contains only devices that are "unknown" (i.e., not virtual, not library, and not defined in an SMC UNITAttr command).

SMC Allocation Processing - JES Operating System Hooks

The SMC examines all I/O device allocations on a JES system to determine whether to process the allocation request.

The SMC uses the MSP subsystem interface (SSI) IEFJFRQ Subsystem Function Request exit to gain control during tape allocation events. The SMC takes control in the JES environment for these Subsystem Functions:

- SSI23 - dynamic allocation
- SSI24 - common allocation

SSI23 Dynamic Allocation

During SSI23 Dynamic Allocation processing, the SMC performs the same functions for dynamic allocations that the POSTSCAN C/I processes for common allocations:

- Drive exclusion
- GDGALL affinity separation
- Esoteric unit name replacement
- Mount deferral

SSI24 Common Allocation

During SSI24 common allocation processing, the SMC performs the following processes to arrive at the best set of eligible drives:

- Drive exclusion
- Unit affinity separation
- Defer processing (when CA1RTS is set to ON)
- EDL updated with the drive exclusion results (when MIACOMPAT is set to ON)

The results of the drive exclusion process are not reflected in MSP control blocks until tape allocation time, unless MIACOMPAT or CA1RTS is set to ON.

The results of unit affinity separation are used to update MSP VOLUNIT entries in the SIOT.

Message Handling

Overview

The SMC intercepts specific MSP and Tape Management System (TMS) messages related to mount, dismount, and swap operations. When the intercepted message includes a drive defined to a TapePlex, the SMC directs the owning TapePlex to perform the requested operation.

Messages that are intercepted by the SMC are listed in [Appendix A, “Intercepted Messages”](#).

User Directed Message Handling

If the SMC does not currently support the Tape Management System at your installation, you can still direct the SMC to intercept the specific messages issued by your TMS. Use the USERMsg operator command to define these additional messages. See [“USERMsg Command” on page 177](#) for more information.

User Exit 01 allows you to change or enhance actions taken on intercepted messages, and can direct the SMC to perform actions on messages that are not in the intercepted message list.

The SMC calls the user exit for each intercepted message. This includes the default messages listed in [Appendix A, “Intercepted Messages”](#) and all messages defined using the USERMsg command.

Note –

- Only messages intercepted by the SMC are passed to the user exit.
 - The SMC does not support the user exit 01 return code of REPLY.
-

Message Handling Policies

The SMC honors the following MSP and SMC policies related to mount, dismount, and swap message handling:

MSP Policies

The System Authorization Facility (SAF) can be used to protect tapes at the volume level (CLASS=TAPEVOL) using your current security software. If defined, the SMC honors the policies defined through the SAF interface regarding the write-protect requirement for a volume mounted on a library transport. The SMC invokes the SAF interface by issuing a RACROUTE macro, and protects read-only volumes through the ACS Virtual Thumbwheel (VTW) support.

SMC Policies

The SMC MOUNTDef command is used to control message handling (i.e., mount/dismount) options previously controlled by the HSC MNTD command, HSC input parameters and LIBGEN options.

These options control the automation of pending mounts, delete disposition at dismount time, whether messages are produced when a library volume is mounted outside the library, and when mount messages are rolled off the console.

Note – See [“MOUNTDef Command”](#) on page 114 for more information.

Tape Management System Support

The SMC interprets Mount, Dismount, and Swap messages from the following Tape Management Systems:

- CA-1
- CA-DYNAM/TLMS
- AutoMedia (Zara)
- CONTROL-T

For tape management systems that supply a subpool, the subpool is interpreted by the SMC and used as the requested subpool name, unless overridden by user exit 01 or a TAPEREQ statement. Related messages include:

- CTS002
- CTT101A
- CTT104A
- TMS002

SMC Swap Processing

The SMC automates the swap process (I/O error or operator initiated) in the same manner as HSC enhanced swap processing. This eliminates the need for operators to find a compatible “swap-to” device when DDR has chosen an incompatible device. If the SMC cannot find a compatible swap-to device, or if all compatible devices are busy, the SMC issues a message and control is returned to DDR processing with no further SMC involvement. Note that enhanced swap processing is the only mode supported in SMC.

The SMC swap process begins when one of the following messages is issued:

```
KHE200I SWAP XXX1 TO XXX2 - I/O ERROR
KHE203I ERROR ON XXX1, SELECT NEW DEVICE
KHE205I SWAP XXX1 - I/O ERROR
```

If device *XXX1* is known to the SMC as a library device, the SMC suppresses the message and begins the automatic swap process.

The SMC issues one of two messages:

```
SMC0108 No compatible drive found for SWAP processing
```

Or when a compatible drive can be selected by the SMC:

```
SMC0107 SWAP volser from XXX1 to XXX2
```

Device *XXX2* is the SMC-selected device that has been determined to be compatible for the swap. The SMC next suppresses the MSP KHE201D or KHE206D message and replaces the message with:

```
SMC0110 Allow swap of volser from XXX1 to XXX2;
Reply 'Y', or 'N' or DEVICE
```

The operator may approve the device selected, cancel the swap or choose a different device. If the operator selects a different device, the SMC accepts the device with no further compatibility checking.

If the reply is 'Y' or a new device, MSP issues the following message:

```
KHE202I PROCEED WITH SWAP OF XXX1 TO XXX2
```

If *XXX1* is a library owned device, the dismount of the volume is automated. If *XXX2* is a library owned device, the mount of the volume is automated.

Note – Ensure that your MSP security package (e.g., RACF, TopSecret) is configured to grant SMC the necessary authority to respond to MSP swap messages KHE201D and KHE206D.

HSC Mount-Related Messages

Certain mount-related messages may still be issued by the HSC due to error conditions.

- SLS0088D is issued when, due to an error condition, a repeated mount for the same volume is required.
- SLS1075D is issued when a dismounted volume encounters an I/O or other type of error.

In addition, the following HSC messages are replaced by SMC messages:

- SLS4306I and SLS4308I are replaced by SMC0106.
- SLS4310D is replaced by SMC0110.

Managing HSC Mounts from the SMC Client

SMC client/server architecture provides the ability to perform management of certain mount/dismount exception conditions from the client console rather than from the server console. Conditions handled by the SMC include the following:

- Displaying messages on the drive and console indicating the volume and its location for manual mounts when an LSM is offline.
- When a drive is found to be loaded with another volume during a mount request from a job in execution, the dismount is forced and the mount is automatically redriven based on the UCB outstanding mount status.

Note – When a mount or dismount message is intercepted by SMC and directed to an HSC server, the SLS0107D message is not issued on the server or client. When a loaded drive condition is detected by the HSC for an SMC directed dismount, the HSC waits one minute for the drive to unload, and then terminates the dismount. If the dismount is performed as part of a mount request from the SMC, the loaded drive status is returned to the SMC, and the SMC then redrives the mount request if the mount is still pending.

- When a drive or volume is in use by another process, verifying that the mount is still pending, periodically retrying the request, and allowing the operator to cancel or retry the request at any time.
- When the TAPEPlex WTORdest Client option is selected, certain WTOR messages are not issued on the HSC server but are sent directly to the client console instead. The operator response to the message is then transmitted back to the server, as SMC redrives the mount or dismount to the server. The following HSC mount/dismount WTOR messages are currently supported with this option:
 - SLS0134
 - SLS0905
 - SLS2126
 - SLS2905
 - SLS2984
 - SLS0109
 - SLS4084

Refer to the *HSC Messages and Codes Guide* for more information about these messages.

Commands and Control Statements

Overview

This chapter describes the following SMC operator commands and control statements, and the methods used to issue them:

- ALLOCDef
- ALLOCJob
- CMDDef
- COMMtest
- Display DRive
- Display Volume
- DRIVemap
- Llist
- LOG
- MOUNTDef
- MSGDef
- MSGJob
- POLicy
- READ
- RESYNChronize
- Route
- SERVer
- TAPEPlex (formerly LIBrary)
- TAPEREQ (control statement)
- TCPip
- TRace
- TREQDEF
- UEXit
- UNITAttr
- USERMsg

Note – See [“Syntax Flow Diagrams” on page 19](#) for syntax flow diagramming conventions.

Issuing SMC Commands

Use any of the following methods to issue SMC operator commands:

- Issue SMC commands using the MSP Modify command
- Issue SMC commands using the SMC command prefix
- Specify SMC commands in the SMCPARMS or SMCCMDS data set(s).

Issuing SMC Commands Using the MSP Modify Command

Use the following command format to issue an SMC command using the MSP Modify (F) command:

```
F started-task-name,command-name [parameter]
```

The following information is included:

- MSP Modify command (F)
- SMC started task name
- Command name
- Parameters (optional or required)

The following example illustrates the MSGDef command:

```
F SMC1MSP,MSGDEF LVL=4
```

Note –

- The started task name and command name **must** be separated with a comma. Spaces are **not** allowed between the subsystem name and command name.
- Parameters and values may be separated with any number of spaces, and may optionally include an equal (=) sign. Values may also be included in parentheses.

The following are equivalent commands:

```
F SMC1MSP,MSGDEF LVL 4  
F SMC1MSP,MSGDEF LVL=4  
F SMC1MSP,MSGDEF LVL(4)
```

Issuing SMC Commands Using the SMC Command Prefix

SMC operator commands can be issued using an SMC command prefix. This prefix is assigned by specifying the SMC CMDDef command in the SMCPARMS data set.

See [“CMDDef Command” on page 96](#) for more information about this command.

Specifying SMC Commands in the SMCCMDS or SMCPARMS Data Set

SMC operator commands specified in the SMCCMDS or SMCPARMS data set are automatically processed at startup. See [“Control Statements” on page 23](#) for syntax conventions used when specifying commands in these data sets.

- The SMCCMDS data set is used for user-configured items that can be changed while the SMC is active. The SMCCMDS data set can be reprocessed using the READ command. The following is a sample SMCCMDS member entry:

```
MSGDEF CASE(MIXED) LVL(4)
TAPEPLEX NAME(HSCPLEX) LOCSUB(HSC0)
READ DSN('MY.PARMLIB(POL)')
TREQDEF DSN('MY.PARMLIB(TREQ)')
RESYNCHRONIZE
```

- The SMCPARMS data set is used for user-configured items that **cannot** be changed while the SMC is active. The SMCPARMS data set **cannot** be reprocessed using the READ command. The following is a sample SMCPARMS member entry:

```
CMDDEF PREFIX(B@F$)
```

Note – It is recommended that you include **only** the CMDDef PREFIX and USERMsg ID parameter settings in the SMCPARMS data set. Specify all other commands in the SMCCMDS data set.

SMC Commands that Specify JOBname, STEPname, and PROCstep

SMC ALLOCJOB, MSGJOB, and TRACE commands allow specification of JOBname, STEPname, or PROCstep. These commands are evaluated by the SMC in order of most specific to least specific job name specification. Therefore, commands can be entered in any order. Consider the following example:

Two ALLOCJOB commands are entered:

```
ALLOCJOB JOBNAME=NOALLOC* MINLVL=4  
ALLOCJOB JOBNAME=NOALLOC1 MINLVL=3
```

Regardless of the order in which these commands are entered, job name NOALLOC1 is processed with MINLVL 3 because this command's job name is more specific than job name NOALLOC*.

Note –

- If an SMC ALLOCJOB or MSGJOB command is entered specifying only JOBname, STEPname, or PROCstep, the command is interpreted as if LIST had also been specified.
 - The above behavior does **not** apply to TAPEREQ statements, which are always evaluated in the order in which they appear in the TREQDEF DD.
-

ALLOCDDef Command

The SMC ALLOCDDef command is used to specify default allocation settings for the SMC subsystem.

Syntax

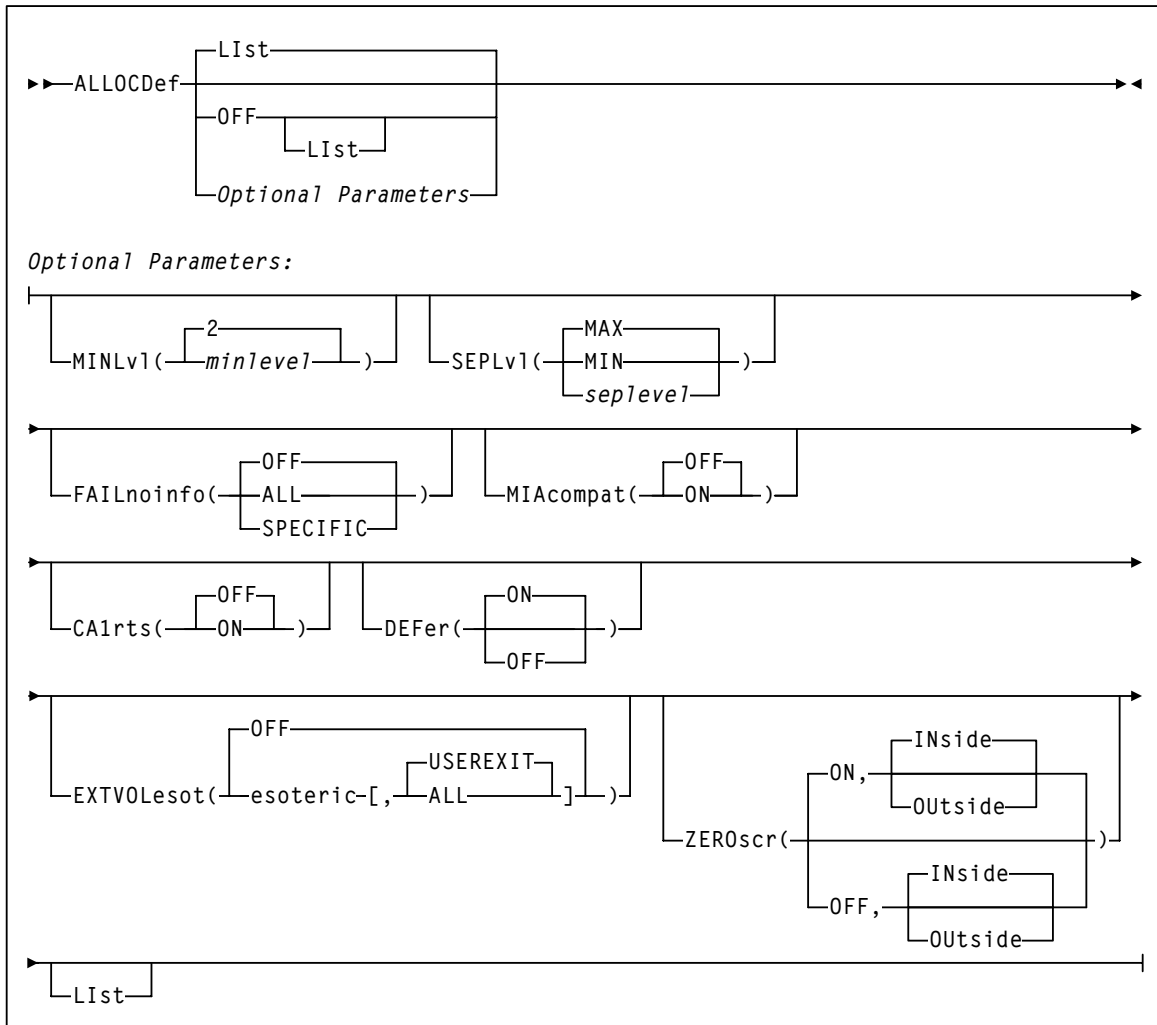

Command Name

ALLOCDDef

initiates the ALLOCDDef command

Parameter Descriptions

LlSt

optionally, lists current default allocation settings

- LlSt is the default when **no** parameters are specified on the ALLOCDDef command.
- LlSt may be specified with other parameters. In this case, the LlSt is generated **after** the other parameters are processed.

OFF

optionally, resets all default allocation values to original SMC default settings. Specify LlSt with this parameter to list these settings.

MINLvl

optionally, specifies the minimum level of drive exclusion. If a job is not allocatable at the minimum exclusion level, the SMC still excludes drives to the minimum level and allows the job to fail.

minlevel

the minimum allocation exclusion level. Valid values are 0-8. 2 is the default value.

Note –

- Setting MINLVL=0 indicates that the job will **not** be failed by the SMC even if the device and specific volume are incompatible. MINLVL=0 may be used to force SMC to allow allocation to succeed when a “foreign” tape cartridge has the same volume serial number as an existing library or virtual volume.
 - Increasing *minlevel* has no effect unless message SMC0045 or SMC0091 has been issued for a specific job step.
 - See [Chapter 5, “Allocation”](#) for more information regarding SMC exclusion levels.
-

SEPLvl

optionally, specifies the exclusion level at which affinity and GDG chains are separated

seplevel

an exclusion level between the minimum and maximum levels. When sufficient drives exist, the SMC attempts to separate chains at this level. This value **cannot** be less than the *minlevel* value.

MAX

Affinity and GDG chains for conflicting exclusion criteria are separated whenever sufficient drives are available. This is the default value.

MIN

Affinity and GDG chains are **not** separated beyond the minimum level.

Note –

- If HSC allocation previously specified UNITAFF(NOSEP) and GDGALL(NOSEP), the default SMC exclusion tables can specify SEPLvl=3 in order to preserve existing behavior for scratch affinity chains with different media types.
 - See [Chapter 5, “Allocation”](#) for more information regarding SMC exclusion levels.
-

FAILnoinfo

optionally, specifies whether the SMC fails a job step during allocation when a communication failure prevents the retrieval of volume information from a TapePlex, or when no TapePlexes are available.

OFF

SMC does **not** fail the job step. This is the default value.

ALL

SMC marks all devices ineligible and fails the job step.

SPECIFIC

If a communication failure occurs during the volume lookup process for a specific volume, or if no TapePlexes are available and the step contains allocations for specific volumes, the SMC marks all devices ineligible and fails the job step.

If the job step contains only scratch allocations, then the job step is allowed to proceed and allocation is based solely on SMC tape policy specifications.

MICompat

optionally, specifies whether the EDL is updated at SSI24 time for compatibility with Computer Associates Unicenter CA-MIA Tape Sharing product.

OFF

The EDL is **not** updated at SSI24 time. This is the default value.

ON

The EDL is modified at SSI24 time. Specify this value if you use Unicenter CA-MIA.

CA1rts

optionally, specifies whether the DEFER processing is performed at SSI24 time for compatibility with Computer Associates Real Time Stacking feature of its CA-1 tape management system.

OFF

DEFER status is **not** updated at SSI24 time. This is the default value.

ON

DEFER status is updated at SSI24 time. Specify this value if you use the Real Time Stacking feature of CA-1.

DEFer

optionally, enables or disables deferred mount processing for library mounts. With deferred mounting enabled, a library resident volume is mounted when the data set is opened. If the data set is not opened, the cartridge is not mounted, freeing the robot to perform other work. If the data set is opened, however, the job waits until the cartridge is mounted.

ON

enables deferred mount processing. This parameter overrides the user's JCL and defers all ACS mounts until the data set is opened. **This is the default setting for JES environments.**

OFF

disables deferred mount processing and honors user JCL specifications

EXTVOLesot

optionally, directs the SMC to use a specified esoteric to allocate a specific external volume (i.e., a volume that is not in a TapePlex). When this esoteric is used depends upon the setting of the modifier value specified after the esoteric, as well as whether the specified esoteric is valid (intersects with the original esoteric specification).

OFF

EXTVOLesot processing is disabled. Nonlibrary drives are selected, if possible, when a specific external volume is allocated. This is the default value.

esoteric,USEREXIT

specifies an esoteric to be used to allocate a specific external volume when the "use specvol" (UX08) return code is specified. If the specific volume user exit returns the "use specvol" (UX08) return code for this DD, then any drives in the specified esoteric that intersect with the original esoteric will be selected for allocation. This is the default value if esoteric is specified.

esoteric,ALL

Whenever an external volume is allocated, drives in the specified esoteric are selected.

ZEROscr

optionally, specifies the exclusion action when there are no scratch volumes in any TapePlex (ON or OFF), or in one or more ACSs within a TapePlex in a multiple ACS environment (INside or OUtside)

ON

This is the default value. ON indicates one of the following:

- If scratch subpools are not being used, and one or more ACSs contain zero scratch volumes, then drives in those ACSs are excluded from the list of eligible devices.
- If a scratch subpool is being requested (either through TAPEREQ or User Exit 02), and one or more ACSs contain zero scratch volumes in the requested subpool, then drives in those ACSs are excluded from the list of eligible devices.

INside

All nonlibrary drives are excluded when there are no scratch volumes in any ACS, and there are library drives eligible for allocation. This is the default value.

OUtside

All library drives are excluded when there are no scratch volumes in any ACS, and there are nonlibrary drives eligible for allocation.

OFF

All drives in all ACSs are to remain eligible for selection.

INside

All nonlibrary drives are excluded when there are no scratch volumes in any ACS, and there are library drives eligible for allocation. This is the default value.

OUtside

All library drives are excluded when there are no scratch volumes in any ACS, and there are nonlibrary drives eligible for allocation.

Examples

In the following example, the ALLOCDDef command sets the minimum level of allocation exclusion to 4 and specifies that unit affinity and GDGALL chains are separated based on levels 1-4. It also specifies that when a user exit returns "use specvol" (UX08), the allocation should be directed to drives in the esoteric SACS0.

```
ALLOCDDEF MINLVL=4 SEPLVL=MIN EXTVOL=(SACS0,USEREXIT)
```

In the next example, ALLOCDDef settings are set to their default values, and then listed.

```
ALLOCDDEF OFF LIST
```

ALLOCJob Command

The SMC ALLOCJob command is used to override SMC default allocation parameters by job name, step name, and PROC step.

Syntax

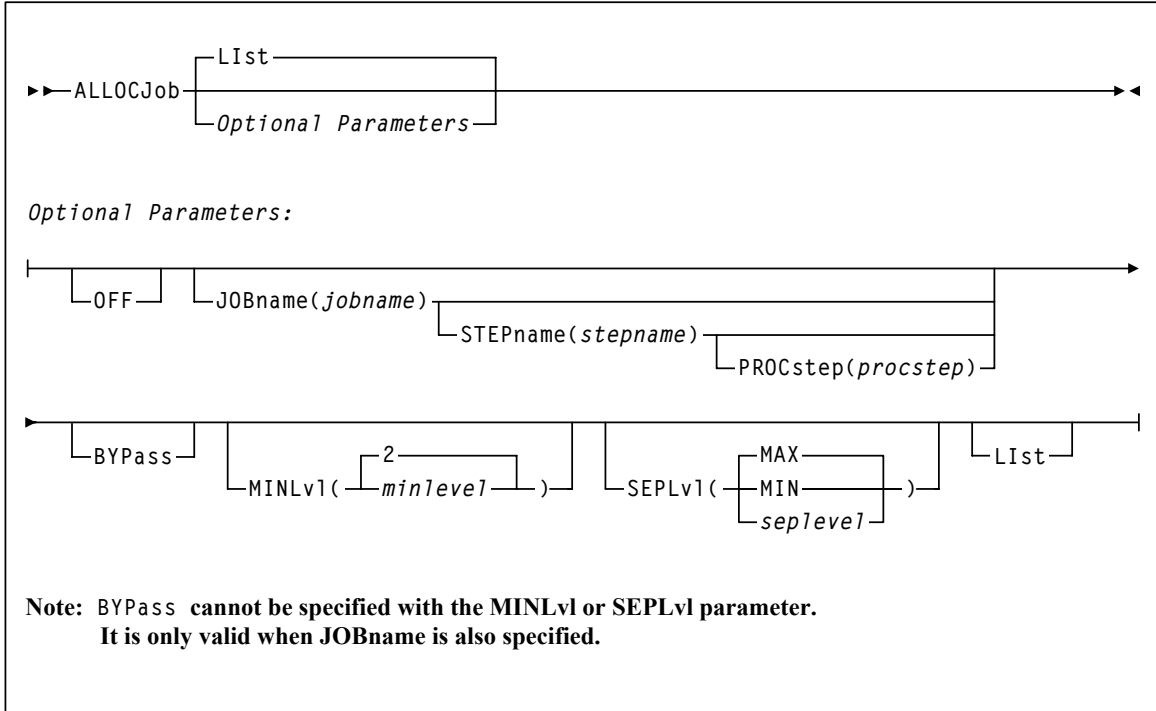

Command Name

ALLOCSJob

initiates the ALLOCSJob command

Parameter Descriptions

List

optionally, lists current default allocation settings and override settings (in the order they are processed) by job name, step name, and PROC step

- List is the default when **no** parameters are specified on the ALLOCSJob command.
- List may be specified with other parameters. In this case, the List is generated **after** the other parameters are processed.

OFF

optionally, removes all job name, step name, and PROC step overrides for allocation

- If no other parameters are specified, allocation overrides are removed for all jobs.
- If only JOBname is specified, allocation overrides are removed for ALL ALLOCSJob entries for that job name.
- If JOBname, STEPname and PROCstep are specified, allocation overrides are removed **only** for the specified entry.

Global allocation settings are **not** affected by this parameter.

JOBname

optionally, specifies a job name

This parameter is required unless List or OFF is specified.

jobname

the job name. The value entered must be one to eight characters in length. An asterisk (*) can be used as a wildcard when included as the last character.

ALLOCSJob is set for all jobs whose job names match the characters preceding the asterisk.

STEPname

optionally, specifies a step name. This parameter is **only** valid when JOBname is also specified.

stepname

the step name. The value entered **must** be one to eight characters in length. An asterisk (*) can be used as a wildcard when included as the last character.

PROCstep

optionally, specifies a PROC step. This parameter is **only** valid when JOBname and STEPname are also specified.

procstep

the PROC step

The value entered **must** be one to eight characters in length. An asterisk (*) can be used as a wildcard when included as the last character.

BYPass

optionally, specifies that SMC allocation influencing is **not** performed for the indicated job (job step, step name, PROC step)

This parameter **cannot** be specified with the MINLVl or SEPLv1 parameter. It is **only** valid when JOBname is also specified.

Note – It is recommended that you use MINLV=0 instead of BYPASS, except when no mounts will be performed (i.e., IEFBR14 jobs).

MINLVl

optionally, specifies the desired minimum level of drive exclusion. If a job is not allocatable at the minimum exclusion level, the SMC still excludes drives to the minimum level and allows the job to fail.

This parameter **cannot** be specified with the BYPass parameter. It is **only** valid when JOBname is also specified.

minlevel

the desired minimum allocation exclusion level. Valid values are 0-8. 0 indicates that the SMC will **not** exclude any drives, even if all drives would be excluded during level 1 exclusion processing. The default is the current value of the ALLOCDEF MINLVL setting. See [Chapter 5, “Allocation”](#) for more information regarding SMC exclusion levels.

Note –

- Setting MINLVL=0 indicates that the job will **not** be failed by the SMC even if the device and specific volume are incompatible. MINLVL=0 may be used to force SMC to allow allocation to succeed when a “foreign” tape cartridge has the same volume serial number as an existing library or virtual volume.
 - Increasing *minlevel* has no effect unless message SMC0045 or SMC0091 has been issued for a specific job step.
-

SEPLv1

optionally, specifies the exclusion level at which affinity and GDG chains are separated

This parameter **cannot** be specified with the BYPass parameter. It is **only** valid when JOBname is also specified.

MIN

Affinity and GDG chains are **not** separated beyond the minimum level.

MAX

Affinity and GDG chains are separated for conflicting exclusion criteria whenever sufficient drives are available. This is the default value.

seplevel

an exclusion level between the minimum and maximum levels. When sufficient drives exist, the SMC attempts to separate chains at this level. See [Chapter 5, “Allocation”](#) for more information regarding SMC exclusion levels.

Note – The *seplevel* value **cannot** be less than the *minlevel* value.

Examples

In the following example, the ALLOCSJob command specifies that job PRODJOB1 with stepnames beginning with STEP1 be allowed to allocate even though SMC determines that volumes are not compatible with any drives in the EDL or esoteric.

```
ALLOCSJOB JOB=PRODJOB1 STEP=STEP1* MINLVL=0
```

In the next example, the ALLOCSJob command specifies that all jobs with jobnames beginning with BYPSMC be ignored by the SMC during allocation processing.

```
ALLOCSJOB JOB=BYPSMC* BYPASS
```

CMDDef Command

The SMC CMDDef command is used to assign an SMC command prefix.

Syntax

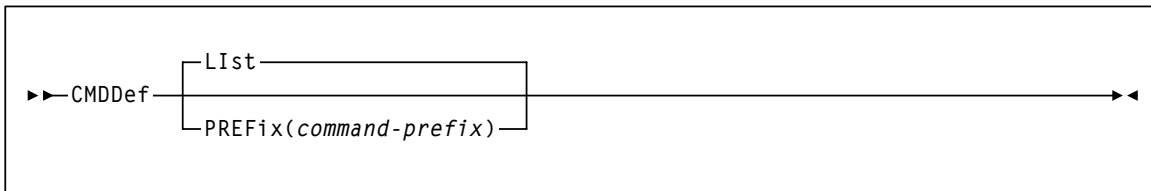

Command Name

CMDDef

initiates the CMDDef command

Parameter Descriptions

LIst

optionally, lists the current command prefix

This is the default if no parameters are specified. It **cannot** be specified with any other parameter.

PREFIx

optionally, specifies a command prefix for the SMC subsystem

This parameter may **only** be specified in the SMCPARMS data set.

command-prefix

the command prefix. The value entered **must** be one to eight characters in length and **must** meet the following requirements:

- Valid characters include:
A-Z 0-9 @ ¢ \$ # , . / ' () < > * & + - = | ! ; : " % _ ?
- The command prefix **cannot** include a command string, a command abbreviation, or any string that invokes a command.
- The command prefix **cannot** include a string that is a subset or superset of an existing prefix beginning with the same character.

Example

In the following example, the CMDDef command is specified in the SMCPARMS data set as follows:

```
CMDDEF PREFIX (B@F$)
```

As a result, SMC operator commands can be entered as follows:

```
B@F$MSGDEF CASE (MIXED)
```

COMMtest Command

The SMC COMMtest command is used to perform an end-to-end communication test between SMC and defined TapePlexes or VLEs. This command can generate a request for all paths to all TapePlexes, regardless of their status. The COMMtest command does **not** update any error statistics or libpath status, but does display messages indicating the communication result.

Note – This command is new for SMC release 6.2.

Syntax

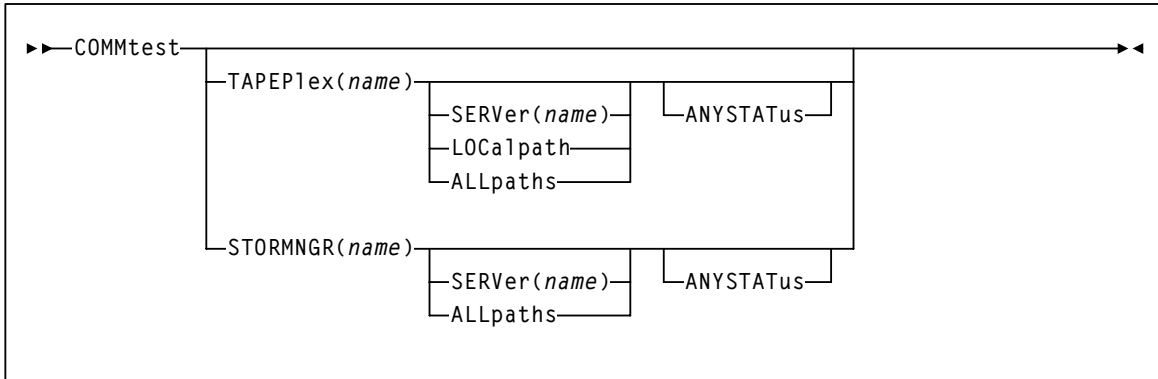

Command Name

COMMtest

initiates the COMMtest command

Parameter Descriptions

TAPEPlex

optionally, restricts communication to the specified TapePlex. By default, communication with all defined TapePlexes is attempted.

name

the TapePlex name as defined by the SMC TAPEPlex command. The following rules apply:

- The value must be between 1 and 8 characters in length.
- The first character must be either an alpha character or digit.
- The last character must be either an alpha character or digit.
- Any character between the first and last must be either an alpha character, digit, or hyphen.

SERVer

optionally, restricts communication to the specified server path. When specifying this parameter, TAPEPlex or STORMNGR must also be specified. By default, communication with all server paths is attempted.

name

the server path name as defined by the SMC SERVer command. The following rules apply:

- The value must be between 1 and 8 characters in length.
- The first character must be either an alpha character or digit.
- The last character must be either an alpha character or digit.
- Any character between the first and last must be either an alpha character, digit, or hyphen.

LOCAlpath

The local server path, if any, is tested. By default, only defined remote server paths are tested.

ALLpaths

All server paths, both local and remote, are tested.

ANYSTATus

Communication is attempted on all communication paths, including paths that were disabled by an operator command or by the SMC. By default, the communications test is performed on any communication path that is active, inactive, or never active. Specification of ANYSTATus also includes disabled communication paths.

STORMNGR

optionally, restricts communication to the specified VLE. By default, communication with all defined VLEs is attempted.

name

a VLE name as defined by the SMC STORMNGR command.

Note – TAPEPLEX and STORMNGR are mutually exclusive.

SERVer

optionally, restricts communication to the specified server path. When specifying this parameter, TAPEPLEX or STORMNGR must also be specified. By default, communication with all server paths is attempted.

name

the server path name as defined by the SMC SERVer command. The following rules apply:

- The value must be between 1 and 8 characters in length.
- The first character must be either an alpha character or digit.
- The last character must be either an alpha character or digit.
- Any character between the first and last must be either an alpha character, digit, or hyphen.

ALLpaths

All server paths, both local and remote, are tested.

ANYSTATus

Communication is attempted on all communication paths, including paths that were disabled by an operator command or by the SMC. By default, the communications test is performed on any communication path that is active, inactive, or never active. Specification of ANYSTATus also includes disabled communication paths.

Example

In the following example, the COMMtest command tests all communication paths, including those that were disabled, for TapePlex PLEX1:

```
COMMTEST TAPEPLEX (PLEX1) ALLPATHS ANYSTATUS
```

Display DRive Command

The SMC Display DRive command is used to request SMC drive attribute and TapePlex ownership information.

Note –

- This command is new for SMC release 6.2.
- TapePlex drive information is also available by issuing the HSC Display Drives command via the SMC Route command.

Syntax

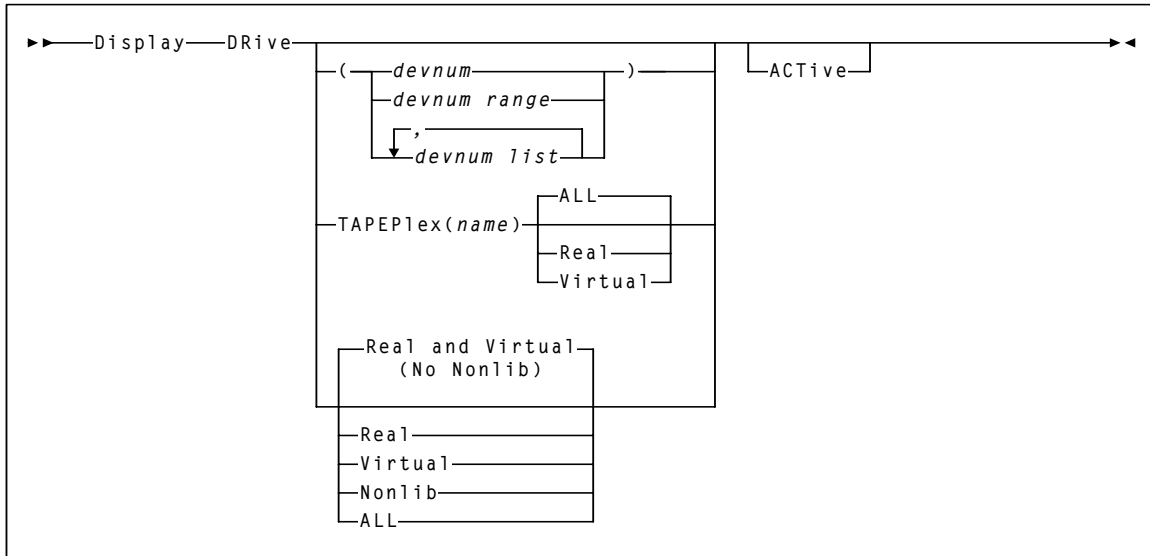

Command Name

Display DRive

initiates the Display DRive command

Parameter Descriptions

devnum, devnum-range, and devnum-list

indicates the device number(s) to be processed. If specified, all device addresses specified are displayed. The *devnum* form of the Display DRive command is the only way that defined devices that are not TapePlex owned, or not defined by an SMC UNITAttr command, can be displayed.

TAPEPlex

optionally, lists **only** devices owned by the specified TapePlex

name

the TapePlex name

Real

optionally, lists **only** “real” (i.e. nonvirtual) devices owned by the specified TapePlex

Virtual

optionally, lists **only** virtual devices owned by the specified TapePlex

ALL

optionally, lists **all** devices owned by the specified TapePlex. This is the default if no parameters are specified.

Real

optionally, lists **only** “real” (i.e. nonvirtual) devices owned by SMC-defined TapePlexes.

Virtual

optionally, lists **only** virtual devices owned by SMC-defined TapePlexes

Nonlib

optionally, lists **only** “real” devices that are not owned by any SMC-defined TapePlex, but have UNITATTR statements defined

ALL

optionally, lists **all** devices owned by SMC-defined TapePlexes.

ACTive

optionally, lists **only** drives currently mounted or awaiting mounts according to SMC internal data

Note – If a Display DRive command is issued without any parameters, by default, the SMC lists all real and virtual devices owned by SMC-defined TapePlexes.

Example

In the following example, the Display DDrive command requests drive attribute information for a specific drive address range:

```
DISPLAY DRIVE 2900-2903
```

The following response is displayed:

```
SMC0000 (OPER) D DR 2900-2903
SMC0178 SMC DISPLAY DRIVE:
Addr Location          Model      SMC Status   MSP Status
-----
2900 PLEX1      01:00:04:00 9490      MNTD SCRTCH  allocated
2901 PLEX1      01:00:04:01 9490      none         online
2902 PLEX1      01:00:04:02 9490      DISM 122333  not ready
2903 PLEX1      01:00:04:03 9490      none         online
```

Note – Contrast the output of this display with the Route command example [on page 135](#).

Display Volume Command

The SMC Display Volume command is used to request volume attribute and TapePlex ownership information.

Note –

- This command is new for SMC release 6.2.
 - TapePlex volume information is also available by issuing the HSC Display Volume command via the SMC Route command.
-

Syntax

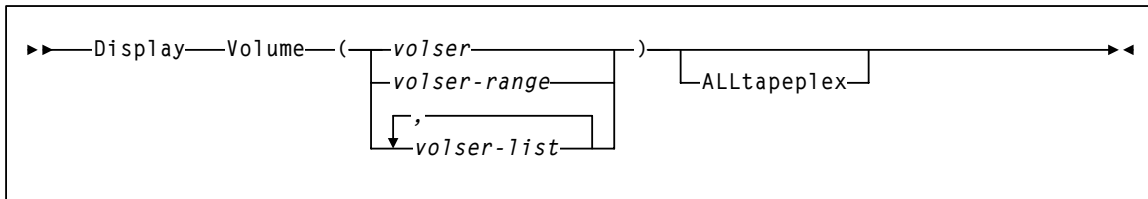

Command Name

Display Volume

initiates the Display Volume command

Parameter Descriptions

volser, volser-range, volser-list

indicates the volser, volser range, or volser list to be processed. If multiple volumes are specified, only the first 100 are queried.

ALLtapeplex

optionally, specifies that all active TapePlexes are queried for the specified volser(s). If specified, multiple display lines may be listed for the same volser if it is defined in multiple TapePlexes.

If this parameter is not specified, the Display Volume command queries TapePlexes in the order they are defined and lists only the first occurrence of the volume.

Example

In the following example, the Display Volume command requests volume attribute and ownership information for a volume range.

```
DISPLAY VOLUME FB2948-FB2952
```

The following response is displayed:

```
SMC0000 (OPER) D VOL FB2948-FB2952
SMC0177 SMC DISPLAY VOLUME:
Volser TapePlex Location Media Rectech Density
-----
FB2948 PLEX1 01:00 STANDARD LONGITUD default
FB2949 PLEX1 01:00 STANDARD LONGITUD default
FB2950 PLEX1 01:00 STK2P STK2P default
FB2951 PLEX1 00:00 STK2P STK2P34 low
FB2952 not found in any TAPEPLEX
```

Note – Contrast the output of this display with the Route command example [on page 135](#).

DRIVemap Command

The SMC DRIVemap command is used to map client drive addresses to server drive addresses. This command allows users to specify different MSP device addresses on different hosts for the same TapePlex or virtual drives in client-server mode.

Note –

- See [Chapter 2, “SMC and StorageTek TapePlex Management”](#) for more information about drive mapping.
- See [“Client/Server Drive Address Mapping” on page 46](#) for information about using DRIVemap commands and the HSC DRVHOST parameter when client and server addresses differ.

Syntax

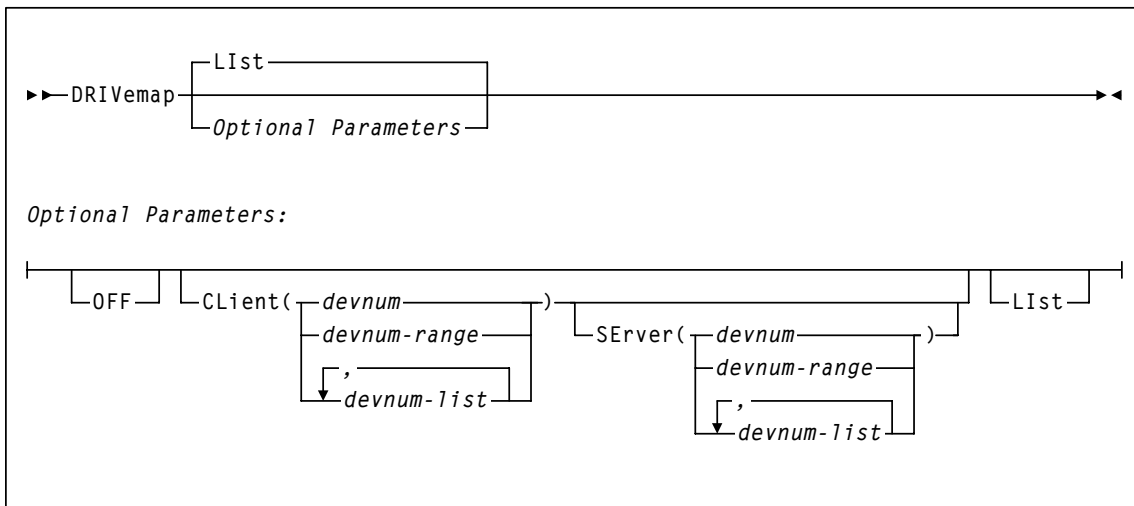

Command Name

DRIVemap

initiates the DRIVemap command

Parameter Descriptions

List

optionally, lists all current DRIVemap mappings

- List is the default when **no** parameters are specified on the DRIVemap command. In this case, all DRIVemap entries are listed.
- List may be specified with other parameters. In this case, the List is applied **after** the other parameters are processed.

OFF

optionally, removes all current DRIVemap mappings. When specified with CLient, this parameter removes DRIVemap ranges specified in the CLient parameter.

CLient

optionally, specifies the device numbers mapped by the DRIVemap command

devnum, devnum-range, devnum-list

the device number, device number range, or device number list

SErver

optionally, specifies the device numbers that are defined on the HSC server

devnum, devnum-range, devnum-list

the device number, device number range, or device number list

The ranges and lists must match those in the CLient parameter. For example:

CL(AA0-AA2) SE(BA0-BA2) is valid;

CL(AA0-AA2) SE(BA0, BA1, BA2) is invalid.

Example

In the following example, the DRIVemap command maps a set of client drive addresses (BA0-BAF) to a set of server drive addresses (AA0-AAF):

```
DRIVEMAP CLIENT(BA0-BAF) SERVER(AA0-AAF)
```

LIBrary Command (SMC 6.1)

In SMC Release 6.2, the SMC LIBrary command is replaced by the SMC TAPEPlex command. However, existing LIBrary commands are still processed for SMC 6.1 compatibility.

See [“TAPEPlex Command” on page 144](#).

Llist Command

The SMC Llist command is used to display storage accessible from the SMC started task address space.

Syntax

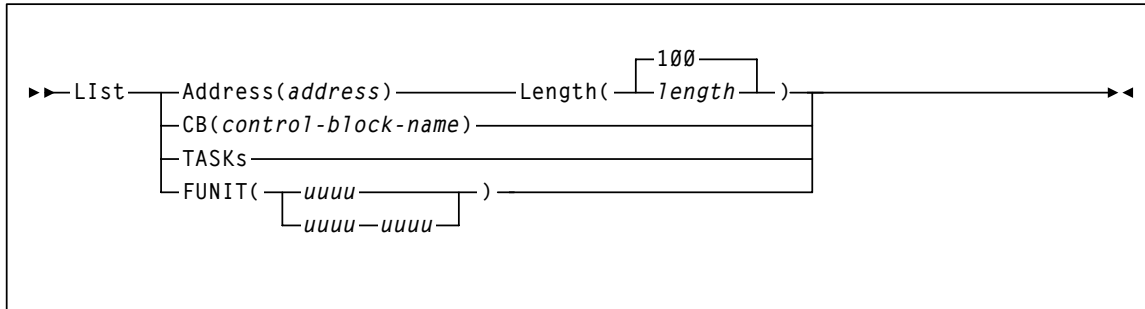

Command Name

Llist

initiates the Llist command

Parameter Descriptions

Address

optionally, specifies the address at which to begin listing SMC memory contents
address

the address. The value entered **must** be a valid hexadecimal address.

Length

optionally, specifies the length of SMC memory (bytes) to be listed. Length is required if Address is specified.

length

the length.

The value entered **must** be a valid hexadecimal value between 1 and FFFF. Memory is listed beginning at the location specified in the *address* parameter. The default value is 100 (decimal 256).

CB

optionally, specifies the internal SMC control block to be listed

control-block-name

the control block name

SMC control blocks are listed for diagnostic purposes. Specify *control-block-name* only as directed by StorageTek Support.

TASKs

optionally, lists the tasks in the SMC subsystem address space

FUNIT

optionally, lists SMC control blocks associated with the specified unit address(es)

uuuu or *uuuu-uuuu*

the unit address(es)

Example

In the following example, the Llist command displays the given length (FFF) of accessible storage beginning with address 01FE00.

```
LIST ADDRESS=01FE00 LENGTH=FFF
```

LOG Command

The SMC LOG command logs XML transactions sent and/or received from TapePlexes and servers to an SMCLOG file. Outgoing requests and incoming responses can be logged from both local and remote TapePlexes. This command is intended to be used primarily as directed by StorageTek Software Support.

In addition, you may specify command parameters to control the following:

- Length of the log data line written (independently of the SMCLOG DCB attributes)
- Whether log data is appended to an existing file
- Handling of SMCLOG EOF conditions

Note – EOFRESTART, used to restart logging at SMCLOG EOF, simply restarts the log at EOF and does not wrap the log (i.e., all data prior to EOF is lost).

Syntax

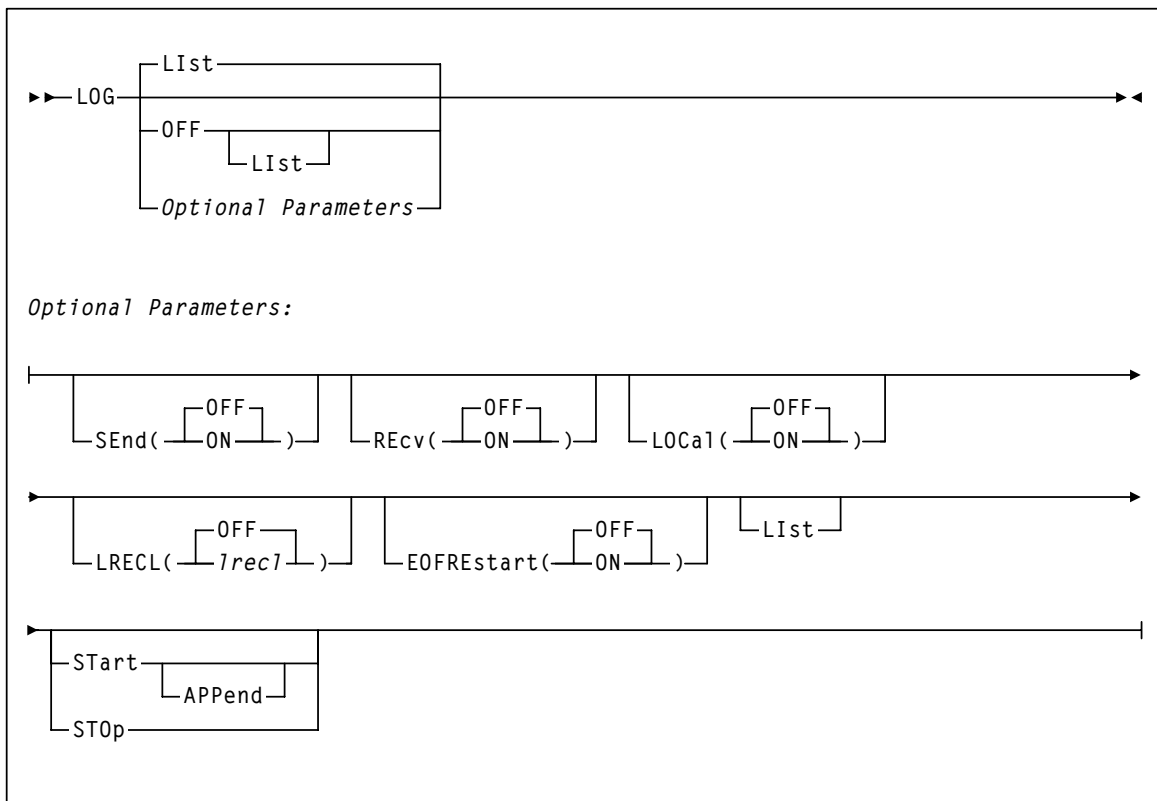

Command Name

LOG

initiates the LOG command

Parameter Descriptions

LlSt

optionally, lists current SMC LOG settings

- LlSt is the default when **no** parameters are specified on the LOG command.
- LlSt may be specified with other parameters. In this case, the LlSt is applied **after** the other parameters are processed.

OFF

optionally, resets all LOG settings to original SMC default settings and stops SMC logging (if started). Specify LlSt with this parameter to list these settings.

SEnd

optionally, specifies whether request data sent to a TapePlex is logged in the SMCLOG file

OFF

Requests sent to a TapePlex are **not** logged to the SMCLOG file. This is the default value.

ON

Requests sent to a TapePlex are logged to the SMCLOG file.

REcv

optionally, specifies whether response data received from a TapePlex is logged to the SMCLOG file

OFF

Responses received from a TapePlex are **not** logged to the SMCLOG file. This is the default value.

ON

Responses received from a TapePlex are logged to the SMCLOG file.

LOCal

optionally, specifies whether the local data, in addition to remote (TCP/IP) requests and responses, is logged to the SMCLOG file

Note – Data sent and received over TCP/IP to remote servers is always logged.

OFF

Data sent and received from a local TapePlex using cross memory services is **not** logged to the SMCLOG file. This is the default setting.

ON

Data sent and received from a local TapePlex using cross memory services is logged.

LRECL

optionally, specifies the line length written to the LOG file

nnnnn

a value from 80 to 32767, used to limit the logical line length.

If the data sent or received exceeds the specified LRECL, then multiple lines are written. If LRECL is specified, then the log date and time stamp are written as separate LOG records. If this value exceeds the DCB LRECL, then the DCB LRECL is used.

OFF

The maximum line length is controlled by the DCB LRECL. The LOG record is appended to the log date and time stamp. This is the default setting.

EOFREstart

optionally, specifies the response when the LOG file reaches End of File (EOF)

OFF

Logging stops at EOF.

ON

The LOG file closes and re-opens at EOF, and logging continues.

STArt

optionally, starts logging

APPend

optionally, specifies that data is appended to the current LOG file when logging is started. If not specified, then data is added to the LOG file from the beginning of the log file, and any data currently in the log file is lost. APPend can only be specified when STArt is also specified.

STOp

optionally, stops logging. Current LOG settings are preserved.

Example

In the following example, the LOG logical record length is set to 120, the log is started, and then the log settings are listed.

```
LOG LRECL(120) START LIST
```

MOUNTDef Command

The SMC MOUNTDef command is used to control message processing (i.e., mount/dismount) options previously controlled by the HSC MNTD command, HSC input parameters and LIBGEN options.

These options control the automation of pending mounts, delete disposition at dismount time, whether messages are produced when a library volume is mounted outside the TapePlex, and when mount messages are rolled off of the console.

Syntax

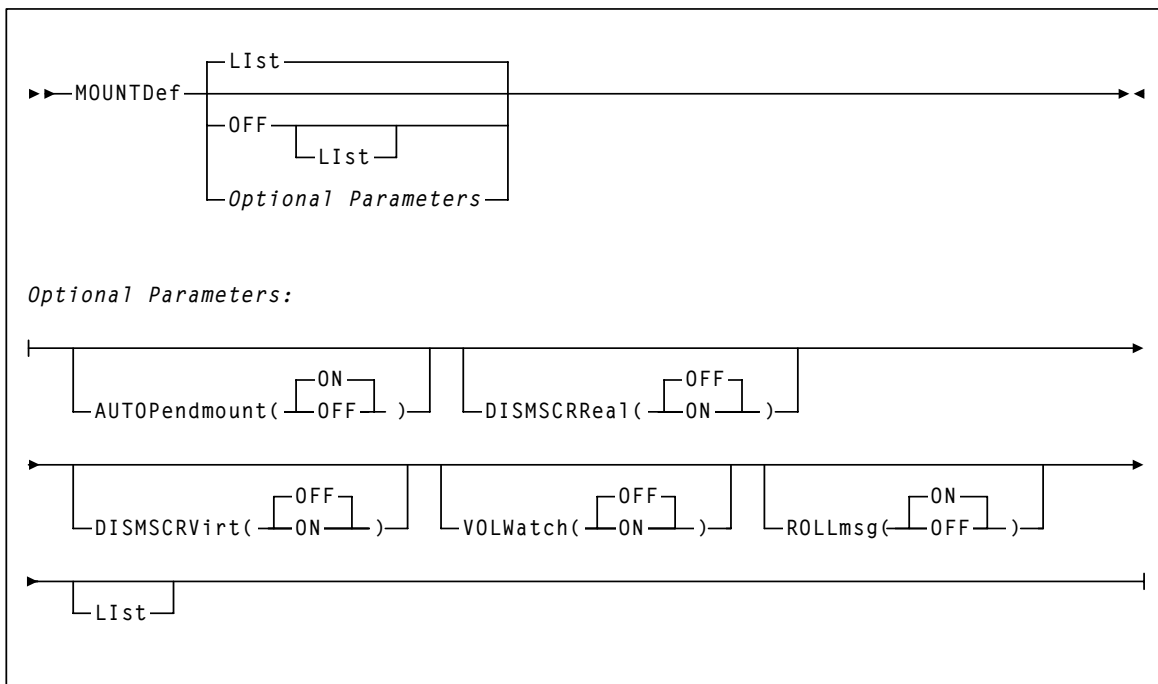

Command Name

MOUNTDef

initiates the MOUNTDef command

Parameter Descriptions

Llist

optionally, lists current SMC MOUNTDef settings

- Llist is the default when **no** parameters are specified on the MOUNTDef command.
- Llist may be specified with other parameters. In this case, the Llist is generated **after** the other parameters are processed.

OFF

optionally, resets all MOUNTDef settings to original SMC default settings. Specify Llist with this parameter to list these settings.

AUTOPendmount

optionally, specifies whether pending mounts are automated for library or virtual drives found when SMC is first initialized and the owning TapePlex is first activated.

ON

Pending mounts are automated. This is the default setting.

OFF

Pending mounts are **not** automated.

Note – If AUTOPendmount is OFF, you must issue an HSC MOUNT command to complete any pending mounts found when a TapePlex is first activated.

DISMSCRReal

optionally, specifies how the SMC interprets the delete disposition on a dismount message for real (nonvirtual) volumes

Note – The DISMSCRReal and DISMSCRVirt parameters replace the DELDISP= parameter of the HSC LIBGEN SLILIBRY macro.

OFF

The real cartridge is retained as nonscratch when MSP indicates delete disposition in the dismount message. This is the default setting, and is recommended for CA-1 or CA-TLMS users to leave volumes in a consistent nonscratch status during the CA-1 and CA-TLMS grace period.

ON

The real cartridge is scratched when MSP indicates delete disposition in the dismount message.

DISMSCRVirt

optionally, specifies how the SMC interprets the delete disposition on a dismount message for virtual volumes

Note – The DISMSCRReal and DISMSCRVirt parameters replace the DELDISP= parameter of the HSC LIBGEN SLILIBRY macro.

OFF

The virtual volume is retained as nonscratch when MSP indicates delete disposition in the dismount message. This is the default setting.

ON

The virtual volume is scratched when MSP indicates delete disposition in the dismount message.

VOLWatch

optionally, specifies whether an SMC message is issued when a library volume is to be mounted on a nonlibrary drive

OFF

No message is issued when a library volume is to be mounted on a nonlibrary drive.

ON

A console message is issued when a library volume is to be mounted on a nonlibrary drive.

ROLLmsg

optionally, specifies whether mount messages handled by the SMC are allowed to roll off the operator console before mount requests are satisfied

ON

Mount messages are allowed to roll off the console screen before mounts are satisfied. This is the default setting.

Note – You can limit the rolling of specific mount messages (e.g., TMS007) by presetting the messages xxxxRCDC (Request to Change Descriptor Codes) flag word xxxxRFBF1. The SAMPLIB includes a sample MPF USEREXIT to preset the xxxxRCDC flag.

OFF

Mount messages remain on the console screen until mount requests are satisfied.

Example

In the following example, the VOLwatch option, used to issue a message when a library volume is mounted on a nonlibrary drive, is enabled. Then all of the MOUNTDef settings are listed.

```
MOUNTDEF VOLWATCH(ON) LIST
```

MSGDef Command

The SMC MSGDef command defines the appearance of SMC system messages, and controls which messages are displayed and suppressed.

Syntax

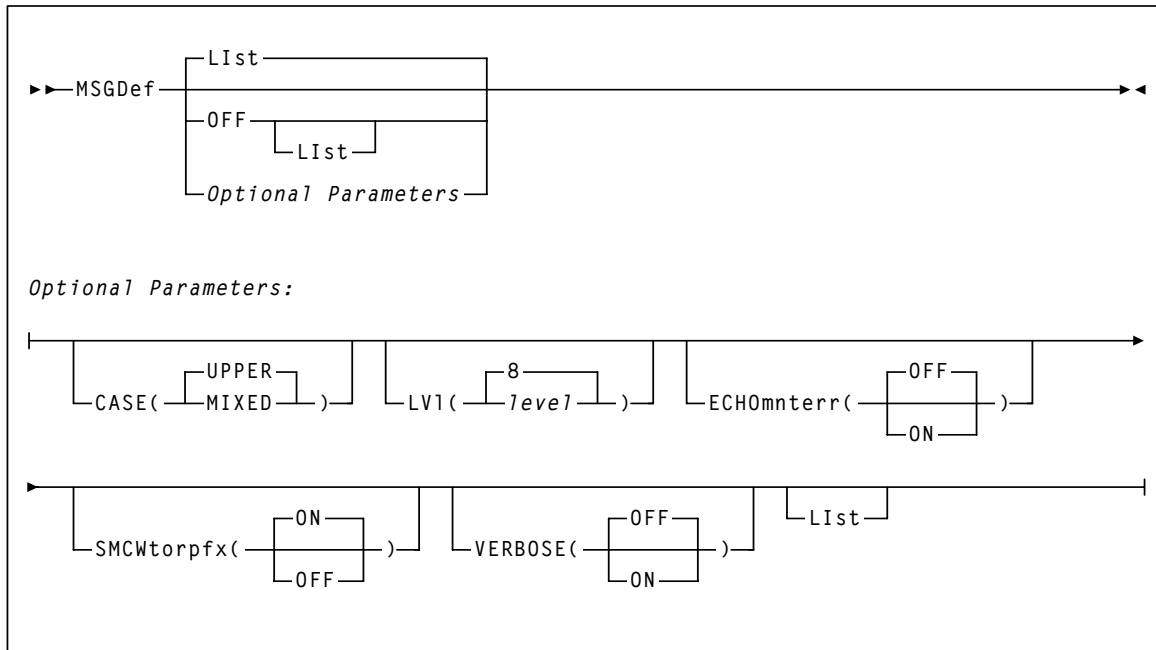

Command Name

MSGDef

initiates the MSGDef command

Parameter Descriptions

List

optionally, lists current default SMC message settings

- List is the default when **no** parameters are specified on the MSGDef command.
- List may be specified with other parameters. In this case, the List is generated **after** the other parameters are processed.

OFF

optionally, resets all MSGDef values to original SMC default settings. Specify List with this parameter to list these settings. MSGDef **cannot** be specified with any other parameter.

CASE

optionally, specifies the message case. Valid values are UPPER or MIXED.

UPPER

specifies upper case. This is the default.

MIXED

specifies mixed case

LVI

optionally, specifies the default level used to control which SMC messages are displayed and suppressed

level

the default level. Valid values include the following:

0	Display error messages only .
4	Display error and warning messages from the SMC subsystem.
8	Display all SMC subsystem messages and allocation job log warning messages. This is the default value if the MSGDef parameter is not specified.

If no value is specified, the default value of 8 is used.

Note – Levels higher than 8 are used for diagnostic purposes and should **only** be specified as directed by StorageTek Software Support.

ECHOmnterr

optionally, specifies whether mount errors generated by the HSC are echoed directly to the console for the SMC client

ON

Mount errors generated by the HSC are echoed to the console for the SMC client.

Note – This parameter is valid for both local and remote servers.

OFF

Mount errors generated by the HSC are **not** to the console for the SMC client. This is the default.

SMCWtorpfx

optionally, specifies whether the SMC0137 prefix is displayed for HSC WTOR messages generated by WTORDEST(CLIENT) on the TAPEplex command

ON

The SMC0137 prefix is displayed. This is the default.

OFF

The SMC0137 prefix is **not** displayed.

VERBOSE

optionally, specifies whether SMC0190 and SMC0191 messages are displayed whenever any SMC settings are altered

ON

SMC0190 and SMC0191 messages are displayed.

OFF

SMC0190 and SMC0191 messages are **not** displayed.

Example

In the following example, the MSGDef command specifies that SMC messages are displayed in mixed case. The command also specifies that **only** error and warning messages from the SMC subsystem are displayed.

```
MSGDEF CASE (MIXED) LVL (4)
```

MSGJob Command

The SMC MSGJob command allows an override of the default message level by job name, step name, and PROC step.

Syntax

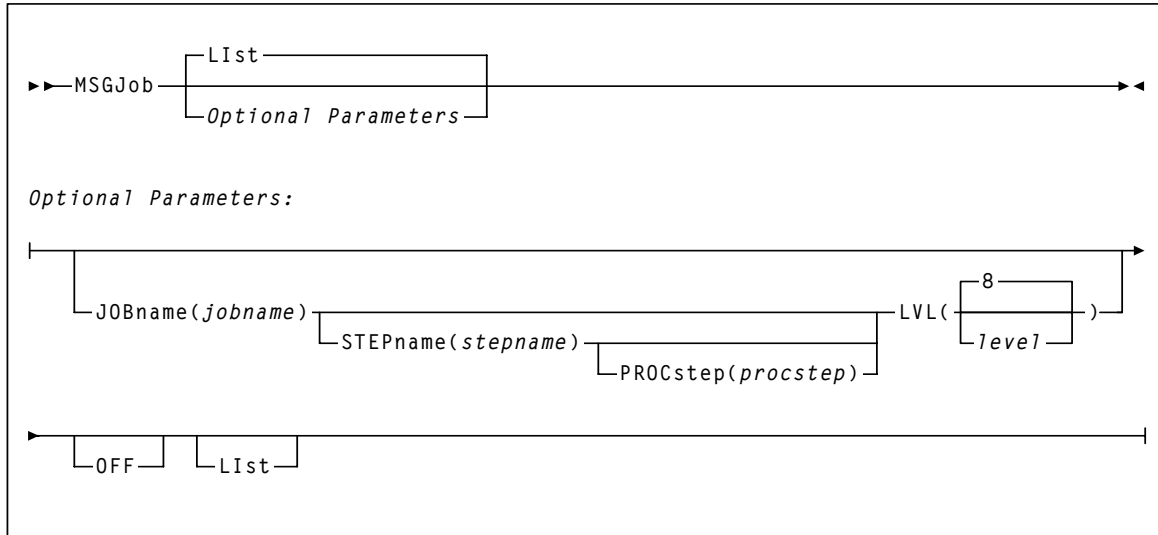

Command Name

MSGJob

initiates the MSGJob command

Parameter Descriptions

LIst

optionally, lists current default SMC message settings and job name, step name, and PROC step exceptions (in the order of evaluation)

- LIst is the default when **no** parameters are specified on the MSGJob command.
- LIst may be specified with other parameters. In this case, the LIst is generated **after** the other parameters are processed.

OFF

optionally, removes MSGJob overrides

- If no other parameters are specified, MSGJob overrides are removed for **all** jobs.
- If only JOBname is specified, MSGJob overrides are removed for **all** MSGJob entries for that job name.
- If JOBname, STEPname and PROCstep are specified, MSGJob overrides are removed **only** for the specified entry.

The global MSGDef is **not** affected by this parameter.

JOBname

optionally, specifies a job name

jobname

the job name

The value entered **must** be one to eight characters in length. An asterisk (*) can be used as a wildcard when included as the last character. In this case, the message level is set for all jobs whose job names match the characters preceding the asterisk.

STEPname

optionally, specifies a step name. It is **only** valid when JOBname is also specified (may be "JOB=*").

stepname

the step name

The value entered **must** be one to eight characters in length. This parameter is **only** valid if JOBname is also specified.

PROCstep

optionally, specifies a PROC step. It is **only** valid when JOBname and STEPname are also specified.

procstep

the PROC step

The value entered **must** be one to eight characters in length. This parameter is **only** valid if JOBname and STEPname are also specified.

LVL

optionally, specifies the default level used to control which SMC messages are displayed. This parameter is required when JOBname is specified.

level

the default level. Valid values include the following:

0	Display error messages only .
4	Display error and warning messages from the SMC subsystem.
8	Display all SMC subsystem messages and allocation job log warning messages.

If no value is specified, the default value of 8 is used.

Note – Levels higher than 8 are used for diagnostic purposes and should **only** be specified as directed by StorageTek Software Support.

Example

In the following example, the MSGJob command specifies that **only** error and warning messages are displayed for job PRODJOB1, step STEP3, PROC step REPORT.

```
MSGJOB JOBNAME (PRODJOB1) STEPNAME (STEP3) PROCSTEP (REPORT) LVL (4)
```

POLicy Command

The SMC POLicy command is used to specify all tape policy specifications in a single named policy object. It can be used with TAPEREQ statements to associate a named policy with an allocation or mount event.

Note –

- **This command is new for SMC release 6.2.**
- See [Chapter 4, “Policy”](#) for more information about the use of SMC policies.
- Policies defined using the SMC POLicy command create SMC policy objects that can be referenced by name from SMC TAPEREQ control statements using the TAPEREQ POLicy parameter. A policy name may be associated with two policy objects: a scratch policy with the specified name, and a specific policy with the specified name.
- Policies referenced from SMC TAPEREQ control statements must be defined prior to executing the TREQDEF command that processes the TAPEREQ control statements.
- When a policy to be added to the SMC contains a policy specification error, for example, specifying a scratch subpool name with VOLTYPE(SPECIFIC), the SMC still creates the policy object. However, the SMC marks the policy object in error, allowing any reference to the named policy object to find it. However, the returned policy will be empty, indicating that the default tape policy attributes will be applied to the event.
- To update an SMC policy, enter a new SMC POLicy command for the given policy NAME and VOLType. Be aware that the new POLicy command **replaces** the existing scratch or specific policy object. Therefore, when updating a policy, you must enter all values you wish to preserve.

For example, if the original scratch policy object is defined as:

```
POLICY NAME(POL1) VOLTYPE(SCRATCH) MEDIA(VIRTUAL) MGMTCLAS(MGMT1)
```

and you wish to add a subpool to the policy, you must enter:

```
POLICY NAME(POL1) VOLTYPE(SCRATCH) MEDIA(VIRTUAL) MGMTCLAS(MGMT1)
SUBPOOL(SUBP1)
```

This behavior allows you to modify one or more POLicy commands in a file and reload all policies using the SMC READ command.

- When an SMC policy object to be updated contains a policy specification error, for example, specifying a scratch subpool name with VOLTYPE(SPECIFIC), the SMC will not update any part of the existing policy object. The policy object is not marked in error, and the complete update is discarded.
 - DEVTPREF is **not** supported on this command. However, you can use an esoteric list to specify preferencing for different device types.
-

Syntax

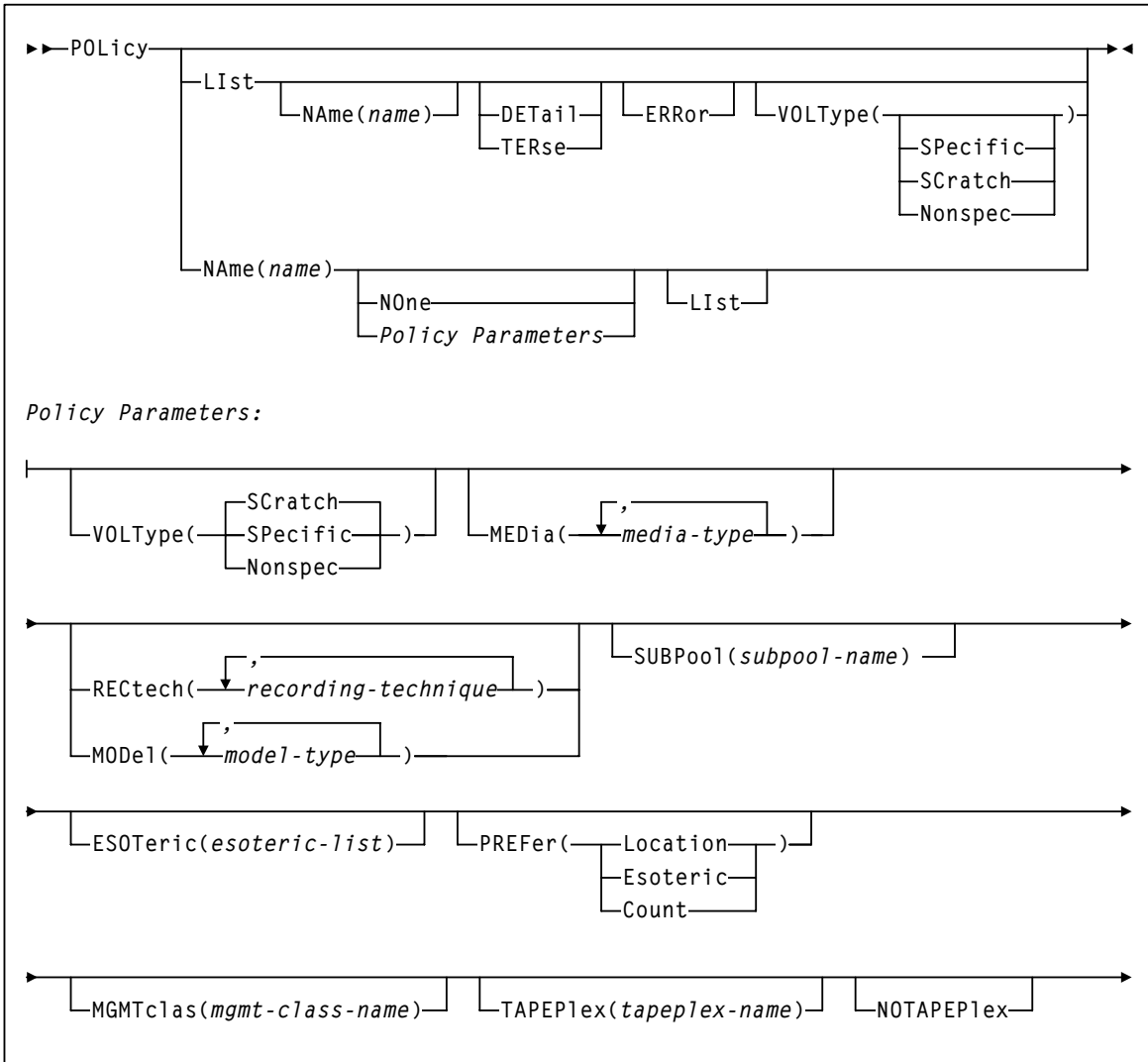

Command Name

POLicy

initiates the Policy command

Parameter Descriptions

Llist

optionally, displays all policy information. Additional parameters allow you to limit which policies are listed, and how much detail is displayed.

NAme

optionally, specifies the name of the policy to be displayed. If the last character is an asterisk (*), all policies that begin with the prefix are displayed. For example, POL LI NA V*.

DETail

optionally, displays audit detail information about the policy, including last update date, time, and source

TERse

optionally, lists only policy names and whether each policy name applies to scratch, specific, or all allocations

ERRor

optionally, displays each policy in error status

When a policy to be added to the SMC contains a policy specification error, for example, specifying a scratch subpool name with VOLTYPE(SPECIFIC), the SMC still creates the policy object. However, the SMC marks the policy object in error, allowing any reference to the named policy object to find it. However, the returned policy will be empty, indicating that the default tape policy attributes will be applied to the event. ERRor lists **only** those policies that contain an error.

VOLType

optionally, specifies whether the list applies to scratch or specific policy types

SCRatch or Nonspec

List **only** scratch (nonspecific) policies.

SPecific

List **only** specific policies.

Note –

- Matching policies are listed in alphabetic order, regardless of the order in which they were defined to the SMC. When specified with other parameters, the Llist is performed **after** the other parameters have been processed.
 - DETail and TERse are mutually exclusive.
-

NAme

specifies the name of a policy that matches the name specified in a TAPEREQ control statement

name

the policy name

NOne

optionally, removes all policy parameters associated with the named policy. Specifying NOne for a policy implies that the default behavior is applied, e.g. any media/rectech, subpool 0, etc.

VOLType

optionally, specifies whether the policy applies to scratch or specific allocation

SCRatch or Nonspec

The policy applies only to scratch (nonspecific) allocations. This is the default.

SPecific

The policy applies only to specific allocations.

Note –

When VOLType(SPecific) is specified:

- The SUBPool parameter is **not** permitted.
 - The MEDia parameter is only permitted if the NOTAPEPlex parameter is specified.
-

MEDia

optionally, specifies the desired media type for a data set being created. You can enter a list of media types, separated by commas. A list specifies a generic pool from which a selection is made. There is no implied priority.

media-type

the media type

See [TABLE B-1 on page 285](#) for a list of valid *media-type* values.

Note –

- MEDia and VOLType(SPecific) are mutually exclusive unless the NOTAPEPlex parameter is specified.
 - If this parameter is not specified, a default is chosen based on the value of the RECtech parameter. See [TABLE B-2 on page 287](#) for default values used if the MEDia parameter is omitted.
 - If both media type and recording technique are omitted, all available device types are eligible for allocation.
-

RECtech

optionally, specifies the method used to record data tracks on the tape surface for the desired data set. You can enter a list of recording techniques, but they must be separated by commas. A list specifies a generic pool from which a selection is made. There is no implied priority.

recording-technique

the recording technique

See [TABLE B-3 on page 288](#) for a list of valid *recording-technique* values.

Note –

- RECtech and MODel are mutually exclusive.
- If this parameter is not specified, a default is chosen based on the value of the MEDia parameter. See [TABLE B-2 on page 287](#) for default values used if the MEDia parameter is omitted.
- If both media type and recording technique are omitted, all available device types are eligible for allocation.

MODel

optionally, specifies the model number of a transport. You can enter a list of models, separated by commas. A list specifies a generic pool from which a selection is made. There is no implied priority.

MODel provides the same type of information as RECtech, but a user may find it more convenient to specify a transport model rather than a recording technique.

model-type

the model type

See [TABLE B-5 on page 292](#) for a list of valid *model-type* values.

Note – MODel and RECtech are mutually exclusive.

SUBPool

optionally, specifies the subpool used to satisfy a scratch request

subpool-name

the subpool name

Note – SUBPool and VOLType(Specific) are mutually exclusive.

ESOTeric

optionally, specifies the name of a device esoteric group, or list of device groups defining the list of eligible transports to be used to satisfy a tape request

esoteric-group-name

the esoteric group name

The name specified can consist of one to eight alphanumeric or national (#, @, \$) characters. A slash (/) or hyphen (-) is also valid.

Note – If the esoteric list contains devices not currently in the Eligible Device List, SMC allocation **cannot** add devices to the list, but can exclude devices not in the specified esoteric. During drive exclusion, devices in any of the listed esoterics are included. During drive prioritization, devices are ordered according to their position in the esoteric list.

PREFer

optionally, specifies the relative value of the esoteric list and additional preferencing information. PREFer is **only** valid when a list of esoterics is specified.

Location

Drives are preferred based on LSM location of a specific volume. This is the default for specific volumes. Location is **only** valid for VOLType (SP).

Esoteric

Drives are preferred based on the order specified in the esoteric list. This is the default for scratch allocations.

Count

Drives are preferred based on scratch counts in the LSM. Count is **only** valid for VOLType (N).

MGMTclas

optionally, specifies a Management Class defined on the VTCS MGMTclas control statement. Refer to the *VTCS Command and Utility Reference* for more information.

mgmt-class-name

the Management Class name

TAPEPlex

optionally, specifies the name of a TapePlex defined to SMC. SMC uses the specified TapePlex name to determine the “owner” of an allocation request. Only the specified TapePlex name is queried to determine specific volume information or scratch availability.

tapeplex-name

the TapePlex name

Note –

- The named TapePlex must be defined using a TAPEPlex command before the POLicy command is processed.
 - TAPEPlex and NOTAPEPlex are mutually exclusive.
-

NOTAPEPlex

optionally, specifies that SMC will **not** perform a TapePlex lookup to obtain volume information

Note –

- NOTAPEPlex and TAPEPlex are mutually exclusive.
 - VOLType (SPecific) is required.
-

Example

In the following example, the POLICY command defines an SMC policy named POLICY1, which specifies management class ABC, subpool XYZ, and the virtual recording technique. Since VOLType is not specified, the policy applies **only** to the default, scratch requests.

```
POLICY NAME(POLICY1) MGMTCLAS(ABC) SUBPOOL(XYZ) RECTECH(V)
```

READ Command

The SMC READ command is used to enter a series of commands using an input data set instead of console commands.

Syntax

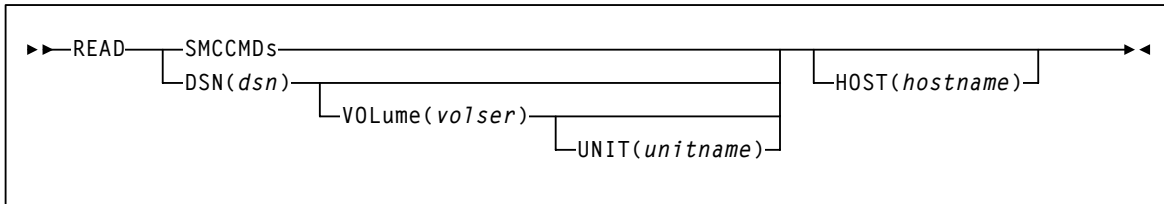

Command Name

READ

initiates the READ command

Parameter Descriptions

SMCCMDS

optionally, re-processes commands contained in the data set specified in the SMCCMDS DD statement of the SMC START procedure

DSN

optionally, processes commands contained in the specified data set

dsn

the data set name

Note – If the DSN parameter specifies a member name, the full data set **must** be enclosed in single quotes.

HOST

optionally, specifies a host name for which this READ command is valid. If this parameter is specified, the READ command is only processed when the specified hostname matches the MSP host. If this parameter is not specified, the READ command is processed regardless of the MSP host.

hostname

the hostname

VOLume

optionally, specifies the volume serial number of the DASD volume on which the data set resides. Specify this parameter if the data set is not catalogued.

volser

the volume serial number on which the data set resides

UNIT

optionally, specifies the unit name of the specified VOLume for uncataloged data sets. Requires that VOLume also be specified.

unitname

the unit name

If not specified, then a unit name of SYSALLDA is the default.

Note –

- HOST is **not** valid when the READ command is entered from an MSP console.
- Specification of the HOST parameter allows you to share a single SMC parameter file set across multiple MSP hosts as shown in the following example:

your.parmlib(COMMCMDs)

```
MSGDEF CASE(MIXED)
...other common SMC parameter settings...
READ DSN('your.parmlib(MSP1CMDs)') HOST(MSP1)
READ DSN('your.parmlib(MSP2CMDs)') HOST(MSP2)
```

your.parmlib(MSP1CMDs)

```
DRIVEMAP CL(AB0-AB7) SE(BB0-BB7)
```

your.parmlib(MSP2CMDs)

```
DRIVEMAP CL(CB0-CB7) SE(BB0-BB7)
```

The file COMMCMDs contains SMC parameter settings applicable to all hosts, and the READ commands with HOST specifications for your MSP hosts. The file MSPS1CMDs contains SMC specifications applicable only to MSP host MSP1, while the file MSP2CMDs contains SMC specifications applicable only to MSP host MSP2.

Example

In the following example, the READ command processes commands included in the MYCMDs member of the MY.COMMAND.PDS data set.

```
READ DSN('MY.COMMAND.PDS(MYCMDs)')
```

RESYNChronize Command

The SMC RESYNChronize command is used to re-establish connections to all defined TapePlexes for the purpose of acquiring drive configuration information from all TapePlexes.

This action is automatically performed when the SMC first activates a new path to a TapePlex, when an HSC subsystem (local or remote) reports a configuration change, or when an active local path to a TapePlex is accessed during an MSP allocation or mount event. However, the operator **must** issue the RESYNChronize command in the following instances:

- When the user wants to automate pending mounts for a newly activated TapePlex, and does not want to wait for an MSP allocation or mount event to trigger the reconnection.
- To attempt to redrive outstanding mounts that may have been lost due to hardware or communication errors.

Note – It is recommended that you include a RESYNC command at the end of your SMCCMDS file (after all TAPEPlex and SERVER commands) to initialize communication with TapePlexes prior to the first intercepted allocation or mount.

Syntax

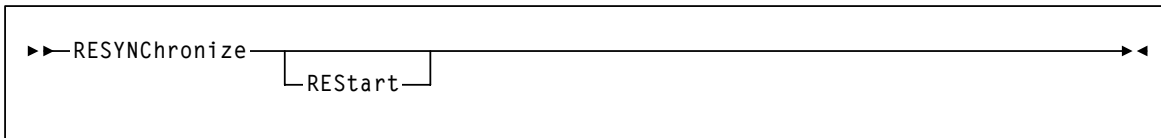

Command Name

RESYNChronize

initiates the RESYNChronize command

Parameter Descriptions

REStart

optionally, starts the RESYNChronize attempt at the first server, regardless of the last active path. REStart also attempts to redrive any outstanding mounts.

Note –

- The SMC RESYNChronize command is **not** required when communicating with HSC, but may be used to redrive outstanding mounts that may have failed due to hardware or communication errors with **either** a local or remote HSC.
 - Use of the RESYNChronize command to automate pending mounts for newly active HSC systems requires that the SMC MOUNTDef AUTOPendmount ON option is specified.
 - Use of the RESYNChronize command to automate pending mounts for newly active HSC systems should be issued after the HSC system has reached FULL service level.
-

Route Command

The SMC Route command is used to request routing of transactions from SMC to a defined TapePlex or VLE. **Only** the following are supported:

- VTCS commands
- HSC commands with UII support, with the exception of VOLRPT.

Note –

- **This command is new for SMC release 6.2.**
 - HSC and VTCS load libraries (SOSLINK and SWSLINK) must be included in the STEPLIB concatenation of the SMC START procedure to support the ability to route HSC and VTCS commands from the SMC to an HSC TapePlex on the same host. See [“Creating the SMC START Procedure” on page 54](#) for more information.
 - HSC and VTCS load libraries (SOSLINK and SWSLINK) must be included in the STEPLIB concatenation of the HTTP Server START procedure to support the ability to route HSC and VTCS commands from a remote SMC to a local HSC TapePlex. See [“Creating the HTTP Server START Procedure” on page 266](#) for more information.
-

Syntax

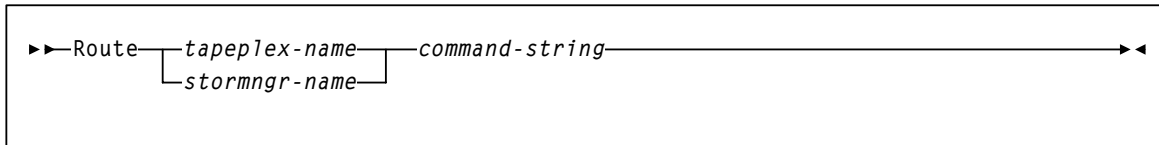

Command Name

Route

initiates the Route command

Parameter Descriptions

tapeplex-name

specifies a TapePlex name as defined on an SMC TAPEPLEX command. SMC routes the request to the specified TapePlex using the currently active TapePlex path. Commands may be sent to either a local or remote HSC TapePlex. This command is **not** supported for MVS/CSC TapePlexes.

stormngr-name

specifies a VLE name as defined on an SMC STORMNGR command. SMC routes the request to the specified VLE using the currently active VLE path. Commands may be sent to either a local or remote HSC TapePlex or VLE. This command is not supported for MVS/CSC TapePlexes.

command-string

specifies the command string to be routed to the requested TapePlex. Note that VTCS commands should not be prefixed with VT; the HSC UII interface routes VTCS commands to the correct functional processor without the VT prefix. The command string must be a command supported by the HSC UII or any VTCS command (except DISPLAY MSG and DISPLAY CMD).

Examples

In the following example, the Route command routes a Display DRive request to TapePlex HSC0:

```
ROUTE PLEX01 D DR DET ALL U(2900-2903)
```

The following response is displayed:

```
SMC0000 (OPER) R PLEX01 D DR DET ALL U(2900-2903)
SMC0173 Response from TAPEPLEX HSC0:
SLS4633I Display Drives Command
DRIVE LOCATION      VOLSER STATUS      MODEL      MEDIA
2900 01:00:04:00      Online  9490      LONGITUD
2901 01:00:04:01      Offline 9490      LONGITUD
2902 01:00:04:02      Online  9490      LONGITUD
2903 01:00:04:03      Offline 9490      LONGITUD
Display of drives complete
SMC0173 Response RC=0
```

In the next example, the Route command routes a Display Volume request to TapePlex HSC0:

```
ROUT PLEX01 D VOL FB2948-FB2952
```

The following response is displayed:

```
SMC0000 (OPER) R PLEX01 D VOL FB2948-FB2952
SMC0173 Response from TAPEPLEX HSC0:
SLS0600I Volume FB2948 ; 01:00:02:06:00, Unselected, Nonscratch
SLS0600I Volume FB2949 ; 01:00:19:00:00, Unselected, Nonscratch
SLS0600I Volume FB2950 ; 01:00:14:00:00, Unselected, Nonscratch
SLS0600I Volume FB2951 ; 00:00:07:00:07, Unselected, Nonscratch
SLS0603I Volume(s) FB2952 not in ACS
SMC0173 Response RC=8
```

Note – Contrast the output of these Route commands with the Display DDrive example [on page 103](#) and Display Volume example [on page 105](#).

SERVer Command

The SMC SERVer command defines a named path to a remote library server; an HSC subsystem executing on another host. The SERVer command describes the communication path to the StorageTek HTTP server.

Note –

- Before a SERVer is defined, the TapePlex that it references must be defined using a TAPEPlex command. The TapePlex name associated with a SERVer **cannot** be changed. See [“TAPEPlex Command” on page 144](#) for more information.
- Similarly, before a SERVer is defined, the VLE that it references must be defined using a STORMNGR command. The VLE name associated with a SERVer cannot be changed. See for more information.

Syntax

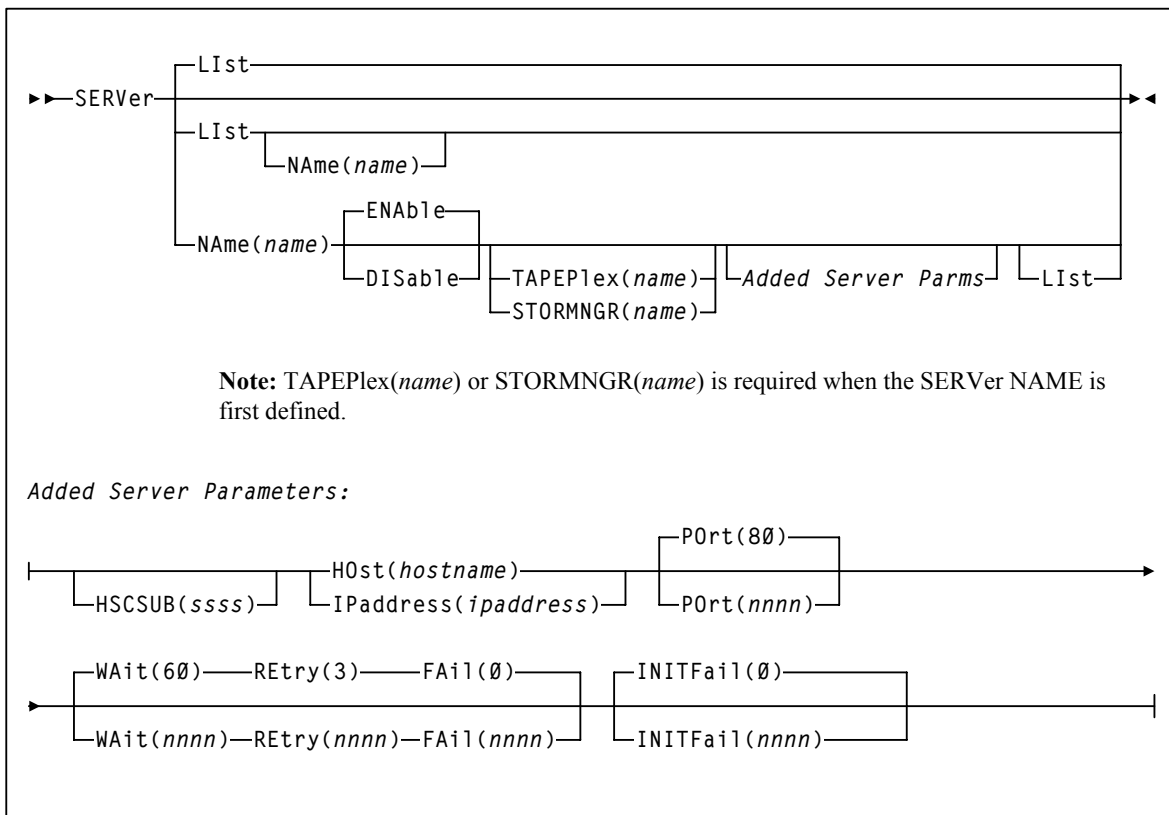

Command Name

SERVer

initiates the SERVer command

Parameter Descriptions

LlSt

optionally, displays status information for TapePlex server paths

- LlSt is the default when **no** parameters are specified on the SERVer command. In this case, all library server paths are listed.
- LlSt may be specified with other parameters. When specified with parameters other than NAmE, the LlSt is generated **after** the other parameters are processed.

NAme

optionally, specifies a TapePlex server path for which status is displayed

name

the TapePlex server path

NAme

optionally, specifies the communication path or route to the server

name

an identifier for the path parameters. This name is reported in any communication error messages. The following rules apply:

- The value must be one to eight characters in length.
- The first character must be an alpha character.
- The last character must be either an alpha character or digit.
- Any character between the first and last must be either an alpha character, digit, or hyphen.

ENable

optionally, enables the specified server path to be selected for allocation or mount requests

DIsable

optionally, disables the specified server path. If this is the only path to the TapePlex, the TapePlex is unavailable for allocation or mount requests.

TAPEPlex

optionally, specifies the TapePlex name associated with an actual ACS hardware configuration. The TAPEPlex parameter **must** be specified when a new server is defined.

name

the TapePlex name. This name is reported in any TapePlex error messages. The following rules apply:

- The value must be one to eight characters in length.
- The first character must be an alpha character.
- The last character must be either an alpha character or digit.
- Any character between the first and last must be either an alpha character, digit, or hyphen.

Note – If you are using the StorageTek HTTP server, there can be multiple named paths to a single TapePlex. See [Chapter 2, “SMC and StorageTek TapePlex Management”](#) for more information.

STORMNGR

optionally, specifies a VLE name as defined on an SMC STORMNGR command. The STORMNGR parameter **must** be specified when a new server is first defined.

name

a VLE name as defined on an SMC STORMNGR command. This name is reported in any VLE error message.

Note – TAPEPlex and STORMNGR are mutually exclusive.

HOst

optionally, specifies the host on which the subsystem resides

hostname

the name of the remote host. The following rules apply:

- The value must be between 1 and 8 characters in length.
- The first character must be either an alpha character or digit.
- The last character must be either an alpha character or digit.
- Any character between the first and last must be either an alpha character, digit, hyphen, or dot.

Note – HOst and IPaddress are mutually exclusive.

IPaddress

optionally, specifies the subsystem IP address

ipaddress

the IP address

Note – IPaddress and HOst are mutually exclusive.

POrt

optionally, specifies the server port

nnnn

the server port. The default is 80.

WAit

optionally, specifies the maximum wait time for any single request made over the network before the SMC assumes that a communication or server problem exists

nnnn

the wait time in seconds. The default is 60.

Note –

- The default for a mount or dismount request is 10 minutes (600 seconds) or more if the specified WAIT time is greater than 600 seconds.
- If your HSC CDS backup job runs longer than the specified wait time, set your wait time to match the normal execution time of your CDS backup job.

REtry

optionally, specifies the number of retry attempts for any single request before the task is allowed to resume, and a failure recorded

nnnn

the number of retries. The default is 3.

FAil

optionally, specifies the number of failures (**after** communication is established) before the server path is disabled or placed out of service

Note – The FAil limit count **only** applies **after** successful communication has been established on this server path.

nnnn

the number of failures. The default is 0.

If 0 is specified, the named server is never automatically disabled due to communications errors. Specify this value when there are no backup server paths to a named TapePlex.

After successful communication is established with a TapePlex, the error severity and server FAil count are used to determine whether a server path should be automatically disabled.

INITFail

optionally, specifies the number of failures (**before** communication is established on the server path) before the server path is disabled or placed out of service

nnnn

the number of failures. The default is 0.

If 0 is specified, the named server is **never** automatically disabled due to communications errors. Use this value only if the library associated with the server is to always be active.

If a remote library may be inactive, specify a small INITFail value, such as 3, for servers associated with the remote library. Specifying a small INITFail value can minimize delays when SMC attempts to communicate with multiple libraries.

Example

In the following example, two TapePlexes (DENVER and OMAHA) are defined.

The first TapePlex, DENVER, has both a local HSC (HSC0, on the SMC host) and a backup remote path on MSP system DEN1. SMC uses the local path unless the local subsystem is inactive or is disabled using the command TAPEPLEX NAME(DENVER) LOCDIS. If the backup remote path is used, selected HSC messages are displayed on the client host.

```
TAPEPLEX NAME(DENVER) LOCSUBSYS(HSC0) WTORDEST(CLIENT)
SERVER NAME(DENBKUP) TAPEPLEX(DENVER) HOST(DEN1) PORT(8888)
```

The second TapePlex, OMAHA, is always accessed using a remote server. The SMC attempts to use the first defined server, OMAHA1. If this server becomes inactive, inaccessible, or is disabled, the SMC uses the next defined server, OMAHA2. If the SMC is unable to communicate with either server, no TapePlex requests are directed to the OMAHA TapePlex.

```
TAPEPLEX NAME(OMAHA) WTORDEST(CLIENT)
SERVER NAME(OMAHA1) TAPEPLEX(OMAHA) HOST(OMA1) PORT(8888)
SERVER NAME(OMAHA2) TAPEPLEX(OMAHA) IP(11.22.33.44) +
PORT(7777)
```

MSP hosts DEN1, OMA1, and the host represented by the IP address 11.22.33.44 must each have an instance of the StorageTek HTTP server executing on them in order for SMC to communicate with the HSC on these hosts. The HTTP server port must be defined as 8888 for the first two hosts and 7777 for the third host.

STORMNGR Command

The SMC STORMNGR command defines a VLE appliance to SMC.

STORMNGR and SERVER commands are required to access a VLE. The STORMNGR command can also list VLEs that the SMC tries to communicate with and report their status.

Syntax

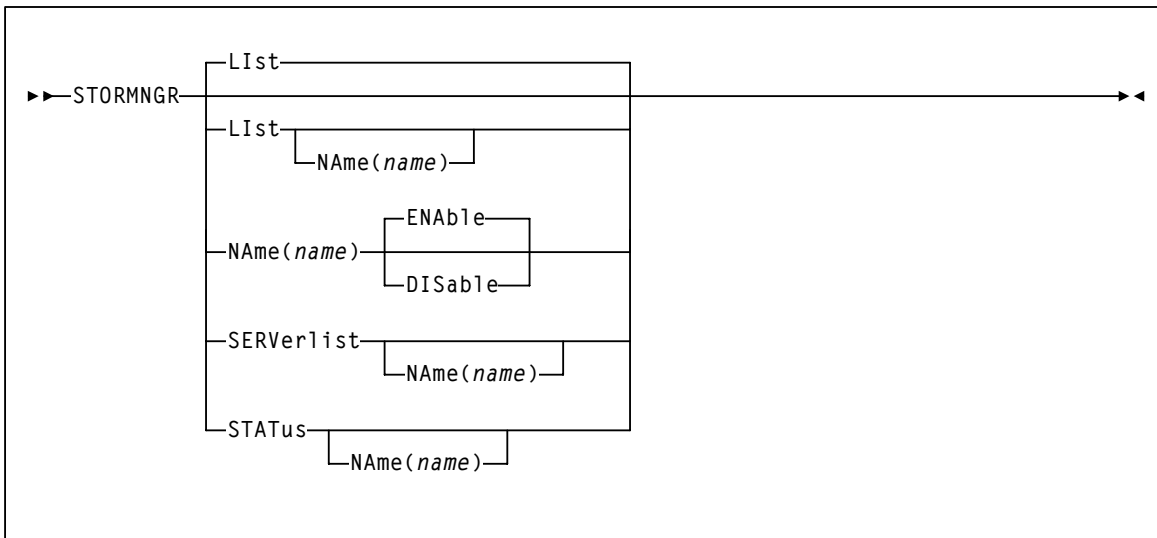

Command Name

STORMNGR

initiates the STORMNGR command

Parameter Descriptions

List

optionally, lists all or a specific VLE.

NAME

If specified, lists the VLE with the specified name.

NAME

Specifies VLE to be added, modified or listed. If NAME is not specified, then all VLEs are listed.

name

the VLE name, which is also defined to VTCS, and is initially defined by the VLE GUI. The following rules apply:

- The value must be between 1 and 8 characters in length.
- The first character must be either an alpha character or digit.
- The last character must be either an alpha character or digit.
- Any character between the first and last must be either an alpha character, digit or hyphen.

ENable

enables the specified VLE. This is the default when new VLE is added.

DISable

disables the specified VLE.

SERVerlist

optionally, lists defined VLEs, their attributes and associated servers. The SERVerlist parameter can also be specified with the NAME parameter to limit the display to a single VLE.

NAME

specifies the VLE name for which servers are to be listed.

name

the VLE name.

STATus

optionally, lists current status of all VLEs or a single named VLE.

TAPEPlex Command

The SMC TAPEPlex command defines a TapePlex; a specific StorageTek tape hardware configuration normally represented by a single CDS.

Note –

- **This command is new for SMC release 6.2. It replaces the LIBRARY command included in previous SMC releases.**
 - TAPEPlex and SERVER commands are required to access remote HSC TapePlexes.
 - If a TAPEPlex command is specified, then all TapePlexes must be explicitly defined.
 - If the TAPEPlex command is not specified, the SMC uses active HSC subsystems defined in the host's SSCVT chain. It is recommended that you use the TAPEPlex command to define all TapePlexes.
-

The TAPEPlex command can also list TapePlexes that the SMC tries to communicate with, and report their status.

Syntax

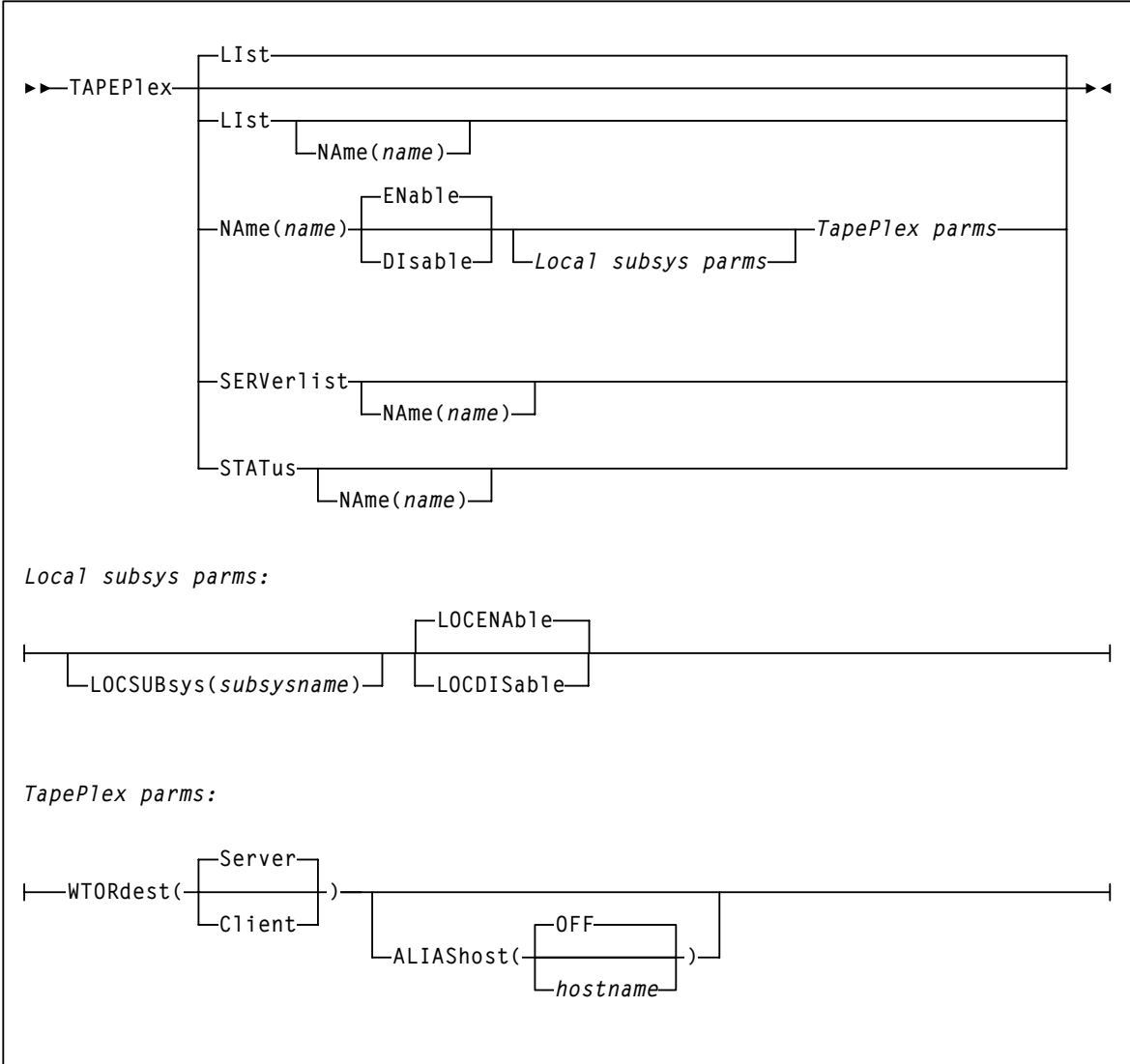

Command Name

TAPEPlex

initiates the TAPEPlex command

Parameter Descriptions

LlSt

optionally, lists the specified TapePlex

NAME

specifies the TapePlex name to be listed

name

the TapePlex name

Note –

- LlSt is the default when **no** parameters are specified on the TAPEPlex command. In this case, all TapePlexes are listed.
 - LlSt may be specified with other parameters. In this case, the named TapePlex is LlSted after the other parameters are processed.
-

NAME

optionally, specifies the TapePlex name to be defined or modified

name

the TapePlex name. The following rules apply:

- The first character must be an alpha character.
- The last character must be either an alpha character or digit.
- Any character between the first and last must be either an alpha character, digit, or hyphen.

ENable

enables the specified TapePlex to be selected for allocation or mount requests

DISable

disables the specified TapePlex. The TapePlex is **not** used for any allocation or mount requests

LOCSUBsys

specifies a local HSC subsystem

subsysname

the subsystem name

LOCENable

enables the specified HSC subsystem to be used as a local path to the TapePlex

LOCDisable

disables the specified HSC subsystem. LOCDisable can be used to force the SMC to ignore the local subsystem and access the TapePlex via a remote server

WTORdest

optionally, specifies the console to which HSC WTOR messages are directed. See [“Managing HSC Mounts from the SMC Client” on page 81](#) for messages that apply.

Client

The remote HSC returns selected WTORs to the SMC client without issuing the WTOR message. The SMC client then issues the WTOR to the operator of the system that the SMC executes on. The SMC redrives the mount or dismount request to the server supplying the WTOR response.

Server

WTOR messages are issued on the HSC server console. This is the default.

ALIAShost

optionally, specifies a host alias to be used in communications with the HSC TapePlex.

hostname

a 1-8 character host name

OFF

The native SMF host name is used in communications with the HSC LIBRARY. This is the default.

SERVerlist

optionally, lists defined TapePlexes, their attributes and associated servers. The SERVerlist parameter may also be specified with the NAME parameter to limit the display to a single TapePlex.

NAME

specifies the TapePlex name for which servers are to be listed

name

the TapePlex name

STATus

optionally, lists current status of all TapePlexes, or a single named TapePlex. The TapePlex status indicates whether a TapePlex is active, inactive, or disabled. For an active TapePlex, the status lists the name of the current server or local subsystem. STATUS does **not** perform a RESYNChronize.

NAME

specifies the TapePlex name for which status information is to be listed

name

the TapePlex name

Examples

In the following example, the TAPEPlex command defines a local HSC subsystem executing on the same host as the SMC.

```
TAPEPLEX NAME (DENVER) LOCSUB (HSC0)
```

In the next example, the TAPEPlex command specifies that the remote subsystem (OMAHA) return selected WTORs to the SMC client without the remote HSC issuing the WTOR message.

```
TAPEPLEX NAME (OMAHA) WTORDEST (CLIENT)
SERVER NAME (OMAHA1) TAPEPLEX (OMAHA) HOST (OMA1) PORT (8888)
SERVER NAME (OMAHA2) TAPEPLEX (OMAHA) IP (11.22.33.44) +
    PORT (7777)
```

Note – The SERVer command must be specified to define the path to the remote TapePlex.

In the next example, the local subsystem name of TAPEPlex BACKUP is changed to HSCB, and then the TAPEPlex entry for HSC will be listed.

```
TAPEPLEX NAME (BACKUP) LOCSUB (HSCB) LIST
```

TAPEREQ (Tape Request) Control Statement

The SMC TAPEREQ statement specifies tape request attributes. These attributes define the media type and recording technique or model number used for a particular data set or group of data sets.

TAPEREQ statements are placed in the definition data set (DDname) specified by the SMC TREQDEF command. SMC allocation calls on these TAPEREQ statements to help ensure that the correct media type is used to satisfy a request, and that the cartridge is mounted on the appropriate device. TAPEREQ statements must be placed in the definition data set; they **cannot** be issued as an operator command.

The new SMC POLICY command allows you to specify all tape policy specifications in a single named object. It can be used with TAPEREQ statements or SMS to associate a named policy with an allocation or mount event.

The optional TAPEREQ POLICY parameter directs the SMC to reference an associated SMC policy defined by an SMC POLICY command. See [Chapter 4, "Policy"](#) for more information. If the POLICY parameter is not specified on the TAPEREQ control statement, SMC reverts to its previous behavior and performs a separate lookup for each required parameter for an allocation or mount event. See page 160 for information about TAPEREQ ordering sensitivity issues.

It is recommended that you convert your existing TAPEREQ statements to use the new SMC POLICY command facility. A TAPEREQ conversion script, included in the SMC SAMPLIB, is provided to assist you in this process. See [Appendix C, "TAPEREQ Conversion Script \(POLCVT02\)"](#) for more information.

Note –

- See ["TREQDef Command" on page 169](#) for information about the TREQDEF Command.
 - Parameters from TAPEREQ lookup, including SUBPool and ESOTeric, always take precedence over values derived from a user exit.
-

Syntax

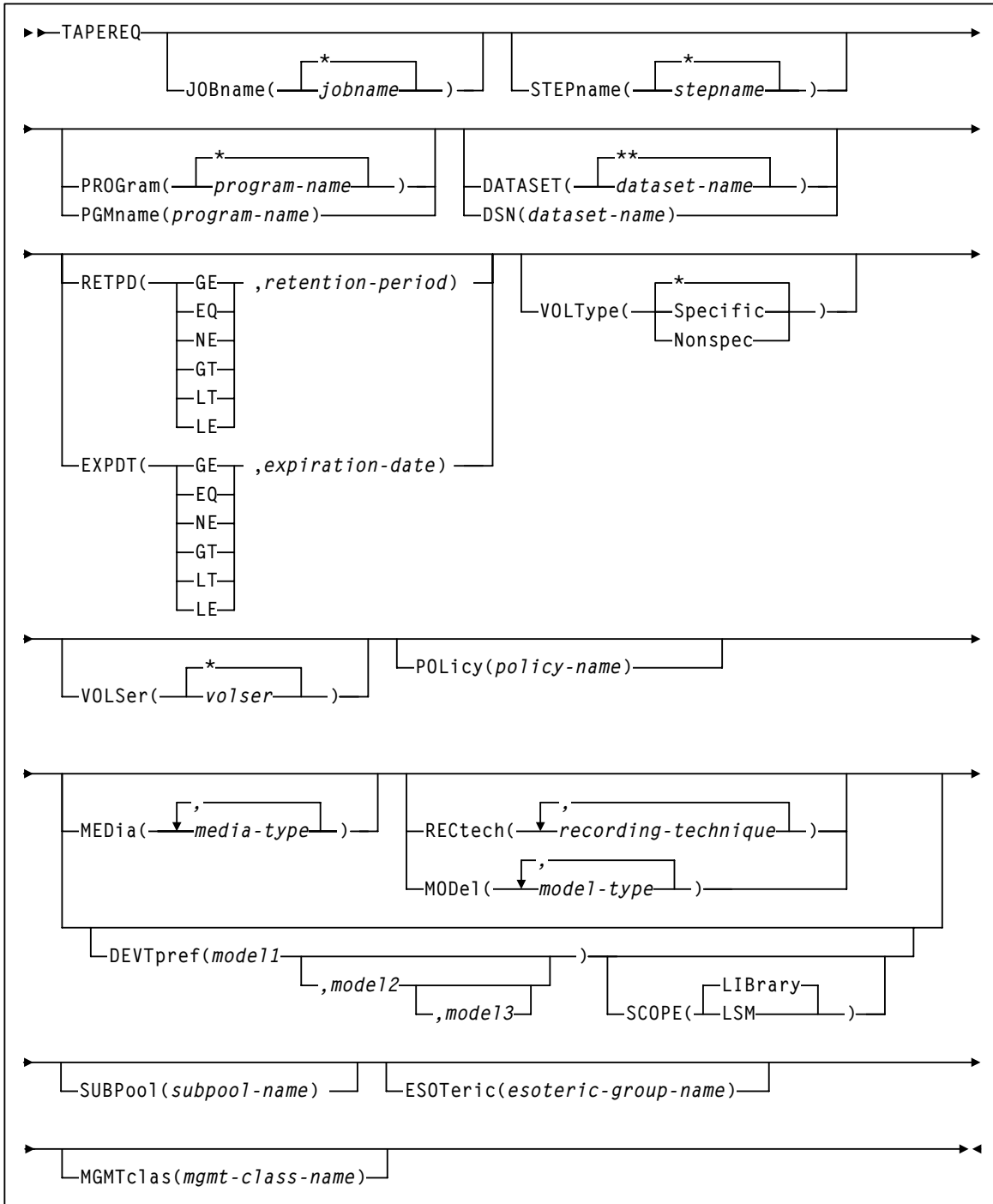

Note – See [Appendix B](#) for valid media types, recording techniques, and model types.

Control Statement Name

TAPEREQ

initiates the TAPEREQ control statement

If any of the following conditions exist:

- There is no TAPEREQ control statement specified in the definition data set to match a request.
- There is no matching TAPEREQ statement or Policy command specifying the MEDia, RECtech, or MODel parameters.
- There is no definition data loaded.

then the MEDia and RECtech or MODel parameters are set to undefined, which matches all requests. Any available device is eligible for allocation.

Parameters

The TAPEREQ control statement is in essence an IF-THEN statement. **IF** the Input (selection criteria) parameters match the current tape request variables, **THEN** the Output (media and format) parameters may apply.

TAPEREQ input and output parameters are described in the following sections.

Input Parameters

Note – The JOBname, STEPname, PROGram, and DATASET parameter values can include the following wild card characters:

% or ?	any single nonblank character
*	any character string (length zero to 8) not to exceed one qualification level. For example, A.B.* matches A.B and A.B.C, but does not match A.B.C.D.
**	used only in DATASET. Indicates any number of qualifiers (zero or more). Cannot be used with any other characters within a qualifier. For example, A.B.** matches A.B, A.B.C, A.B.C.D, A.B.C.D.E, and so forth.

TAPEREQ input (selection criteria) parameters include:

JOBname

optionally, identifies the job name. If JOBname is not specified, the default value is *.

jobname

the name of the job for which the TAPEREQ control statement is processed

The TAPEREQ control statement is used only when the specified *jobname* matches the job name in the request.

STEPname

optionally, specifies the step name. If the STEPname parameter is not specified, the default value is *.

stepname

the name of the step for which the TAPEREQ control statement is processed. The TAPEREQ control statement is used only when the specified *stepname* matches the step name in the request.

PROGname or PGMname

optionally, specifies the program name

The program name used is the job step program name. The default value is *.

program-name

the program name for which the TAPEREQ control statement is processed

The TAPEREQ control statement is used only when the specified *program-name* matches the program name in the request.

DATASET or DSN

optionally, specifies the data set name. The default value is **.

dataset.name

the data set name for which the TAPEREQ control statement is processed

The TAPEREQ control statement is used only when the specified *dataset.name* matches the data set name in the request. Rules for RACF and SMS enhanced generic naming apply.

Note – The name you specify on this parameter might be different from the value coded in the DSN parameter on a DD statement. For example,

DSN=&&ABC

may be coded on a DD statement if a data set is temporary. However, the actual data set name is not &&ABC. Similarly, if the DSN parameter refers back to a previous DD statement, the data set name is resolved to the referred-to data set. Thus, the data set name referred to must be coded on the DATASET parameter in order for the TAPEREQ control statement to be processed.

RETPD

optionally, specifies the retention period and the relationship that must exist. If you do not specify either RETPD or EXPDT, the default value is RETPD(GE,0) (any expiration date will match this criterion).

EQ	equal to.
NE	not equal to.
GT	greater than.
GE	greater than or equal to.
LT	less than.
LE	less than or equal to.

retention-period

the retention period in days for the data set

Specify the number of days as a 1- to 4-digit decimal number.

EXPDT

optionally, specifies the expiration date and the relationship that must exist

EQ	equal to.
NE	not equal to.
GT	greater than.
GE	greater than or equal to.
LT	less than.
LE	less than or equal to.

expiration-date

the expiration date of the data set in YYDDD or YYYY/DDD format

VOLType

optionally, specifies whether or not a nonspecific volume is being requested. If VOLType is omitted, the default value is * (either specific or nonspecific matches).

Specific

specifies that the request is for a specific volume

Note – The TAPEREQ parameter never overrides the actual media type of the specific volume returned by the LCS.

Nonspec

specifies that the request is for a nonspecific (scratch) volume

VOLSer

optionally, identifies a specific volume id. If VOLSer is omitted, the default value is * (any volume). A range of volsers can also be specified.

Using a combination of TAPEREQ statements and POLicy commands, SMC allows you to specify allocation policy based on specific volume serial numbers. See [“Specifying TAPEREQ and Policy by Volume Serial” on page 63](#) for more information.

volsers

the volume id

Note –

- VOLSer requires that the POLicy parameter is also specified.
 - VOLSer is mutually exclusive with VOLType, MEDia, RECtech, MODel, SUBPool, ESOTeric, and MGMTclas.
-

Output Parameters

The TAPEREQ output (media and format) parameters include:

POLicy

optionally, specifies the name of a policy defined by an SMC POLicy command
POLicy is mutually exclusive with VOLType, MEDia, RECtech, MODel, SUBPool, ESOTeric, and MGMTclas.

policy-name

the policy name

The SMC uses this policy name to determine **all** policy information associated with an allocation or mount request.

Note –

- The named policy must be defined using a POLicy command before the TREQDEF command is processed.
 - See [“POLicy Command” on page 123](#) for more information about the SMC POLicy command.
 - See [Appendix C, “TAPEREQ Conversion Script \(POLCVT02\)”](#) for information about creating new POLicy definitions based on existing TAPEREQ statements.
-

MEDia

optionally, specifies the desired type of media for a data set being created. You can enter a list of media types, but they must be separated by commas.

media-type

the media type

See [TABLE B-1 on page 285](#) for a list of valid *media-type* values.

Note –

- A list specifies a generic pool from which a selection is made. There is no implied priority.
 - This parameter is ignored for an existing data set if the media characteristics are determined by the volume information contained in the LCS’s control data set (CDS).
 - If this parameter is not specified, a default is chosen based on the value of the RECtech parameter. See [TABLE B-2 on page 287](#) for default values used if the MEDia parameter is omitted.
 - To avoid problems, all TAPEREQ statements must specify MEDia and RECtech consistently. Be sure to include one or both parameters on each statement. If both media type and recording technique are omitted, all available devices are eligible for allocation.
-

RECtech

optionally, specifies the method used to record data tracks on the tape surface for the desired data set. You can enter a list of recording techniques, but they must be separated by commas.

Note – A list specifies a generic pool from which a selection is made. There is no implied priority.

recording-technique

the recording technique

See [TABLE B-3 on page 288](#) for a list of valid *recording-technique* values.

Note –

- RECtech and MODel are mutually exclusive.
 - If this parameter is not specified on any matching TAPEREQ, a default is chosen based on the value of the MEDia parameter. See [TABLE B-2 on page 287](#) for default values used if the MEDia parameter is omitted.
 - It is recommended that all TAPEREQ statements specify MEDia and RECtech consistently. Be sure to include one or both parameters on each statement. If both media type and recording technique are omitted, all available devices are eligible for allocation.
-

MODel

optionally, specifies the model number of a transport. You can enter a list of models, but they must be separated by commas. MODel provides the same type of information as RECtech, but a user may find it more convenient to specify a transport model rather than a recording technique.

model-type

the model type. See [TABLE B-5 on page 292](#) for a list of valid *model-type* values.

Note –

- MODel and RECtech are mutually exclusive.
 - A list specifies a generic pool from which a selection is made. There is no implied priority.
-

DEVTpref

requests device preferencing for a particular allocation request. The use of device preferencing is restricted to StorageTek 36-track class transport models: 4490, 9490, and 9490EE.

Note – The following rules apply when using the MEDia, MODel, and RECtech parameters in conjunction with DEVTpref:

- The MODel parameter must include the models specified in the DEVTpref parameter.
- The RECtech parameter must include valid values for each model specified in the DEVTpref parameter.
- The MEDia parameter must include valid values for each model specified in the DEVTpref parameter.

model1

specifies the transport model number of the preferred device. These transports are given a higher selection probability than the alternate transport model.

model2

optionally, specifies the transport model number of the first alternate device. It must be separated from the *model1* by either a comma or a blank.

model3

optionally, specifies the transport model number of the second alternate device. It must be separated from *model2* by either a comma or a blank.

If *model3* is omitted, the transport model number not specified by *model1* or *model2* is assumed to be the second alternate device.

The following table shows the alternate device order if only *model1* is entered:

TABLE 7-1 Alternate Device Default Value

<i>Preferred Device (model1):</i>	<i>First Alternate Device (model2):</i>	<i>Second Alternate Device (model3):</i>
4490	9490	9490EE
9490	4490	9490EE
9490EE	4490	9490

Note – Entering DEVTpref(9490,4490) is functionally equivalent to DEVTpref(9490,4490,9490EE).

SCOPE

specifies whether device preferencing should be performed across the entire library complex (single or multiple-ACS), or at the individual LSM level. The SCOPE parameter may be used in an attempt to reduce pass-thru events. SCOPE is valid only when the DEVTpref parameter is specified on the same TAPEREQ statement.

LIBrary

All of the preferred models in the ACS are given a higher selection probability than all of the alternate models, while maintaining the ability to automate tape mounts. LIBrary is the default value.

In a multiple-ACS configuration, the way that the SMC processes SCOPE(LIBrary) depends on the following:

- The ability to automate the mount
- The type of request; specific versus scratch

A specific volume request is confined to the ACS where the volume resides so that the mount can be automated. The transports in all other ACSs, and all nonlibrary transports are marked ineligible for selection. The SMC then applies SCOPE(LIBrary) to one ACS, giving all of the preferred models in that ACS a higher selection probability.

A scratch request can be directed to any ACS, whether or not it contains scratch volumes. In this case, the SMC applies SCOPE(LIBrary) to all ACSs, giving all of the preferred models in all ACSs a higher selection probability.

Note – To prevent a scratch request from being directed to an ACS with no scratch volumes, use ALLOCDef Zeroscr (ON). See [“ALLOCDef Command” on page 87](#).

LSM

All of the preferred models within an LSM are given a higher selection probability than all of the alternate models within that same LSM, while maintaining the ability to automate tape mounts.

Each LSM is processed individually without regard to the models attached to other LSMs in the ACS. This means that if the preferred model is not available in the LSM where the volume resides, an alternate transport in the same LSM is allocated preventing a pass-thru of the volume to a different LSM.

SCOPE(LSM) should be requested if reducing pass-thru events is more important than allocating a preferred transport in a different LSM.

SCOPE applies only when DEVTpref is specified. LIBrary is the default value for the SCOPE parameter.

SUBPool

optionally, specifies the subpool used to satisfy a scratch request

subpool-name

the subpool name

ESOTeric

optionally, specifies the esoteric defining the list of eligible transports to be used to satisfy a tape request

esoteric-group-name

the esoteric group name

The name specified can consist of one to eight alphanumeric or national (#, @, \$) characters. A slash (/) or hyphen (-) is also valid.

Note – If the esoteric contains devices not currently in the Eligible Device List, SMC allocation **cannot** add devices to the list, but can exclude devices not in the specified esoteric.

MGMTclas

optionally, specifies a Management Class you defined on the VTCS MGMTclas control statement. Refer to the *VTCS Command and Utility Reference* for more information.

mgmt-class-name

the Management Class name

Caution – The Management Class applies **only** to virtual allocations and mounts.

Examples

In the following example, a TAPEREQ statement specifies that a 9840 cartridge and 9840 transport be used to satisfy a request for data set A.B.*.

```
TAPEREQ DSN(A.B.*) MODEL(9840) MEDIA(9840)
```

In the following example, a TAPEREQ statement specifies that the SMC policy definition POL1 (defined by an SMC POLicy command) be used to satisfy the request for data set A.C.*.

```
TAPEREQ DSN(A.C.*) POL(POL1)
```

In the following example, a TAPEREQ statement specifies that the SMC policy definition MANUAL be used to satisfy requests for specific volsers in the range AAA000-AAA100.

```
TAPEREQ VOLSER (AAA000-AAA100) POL(MANUAL)
```

Disabling a TAPEREQ Definition

Use the following procedure to disable a TAPEREQ definition.

1. Edit the definition data set containing the current TAPEREQ control statements.
2. Delete the parameters of the TAPEREQ control statement you want to disable, or delete the TAPEREQ control statement.
3. Issue the TREQDEF operator command to reload the definition data set.

To disable all TAPEREQ definitions, load a definition data set that contains only one TAPEREQ control statement with no parameters.

Note – If any individual TAPEREQ control statement is in error, the entire set is discarded.

Order Sensitivity of TAPEREQ Control Statements and Tape Policy Attributes Selected from Multiple TAPEPREQ Control Statements

The TAPEREQ control statement is, in essence, an IF-THEN statement. **IF** the input parameters (or selection criteria) match the current tape request variables, **THEN** the output parameters (or tape policy attributes) may apply.

If the SMC POLICY parameter is not specified on all TAPEREQ control statements, TAPEREQ processing can be order sensitive depending on the selection criteria specified. For example, consider the following TAPEREQ control statements:

```
TAPEREQ DSN(ARBACKUP.** ) MEDIA(VIRTUAL) ESOTERIC(SVTSS1)
TAPEREQ JOBNAME(AR*) MEDIA(STK1R) MGMTCLAS(MCLASS1)
```

If there are jobs with job names beginning with “AR” which also contain data sets beginning with “ARBACKUP.”, then correct media selection depends on both TAPEREQ control statements being processed in the correct order. In this case, different policy attributes are selected from different TAPEREQ control statements. For example, MEDIA and ESOTERIC are selected from the first TAPEREQ control statement, while MGMTCLAS is selected from the second TAPEREQ control statement.

To avoid this situation, it is recommended that you convert your existing TAPEREQ statements to use the new SMC POLICY command facility. A TAPEREQ conversion script, included in the SMC SAMPLIB, is provided to assist you in this process. See [Appendix C, “TAPEREQ Conversion Script \(POLCVT02\)”](#) for more information. This appendix includes an example of output generated from existing TAPEREQ statements.

TCPip Command

The SMC TCPip command alters and/or lists current TCPNAME and ADSNAME defaults for your TCP/IP communications environment. It allows you to direct TCP/IP requests to a specific TCP/IP stack on an MSP host. The TCPip command can be issued at any time.

Syntax

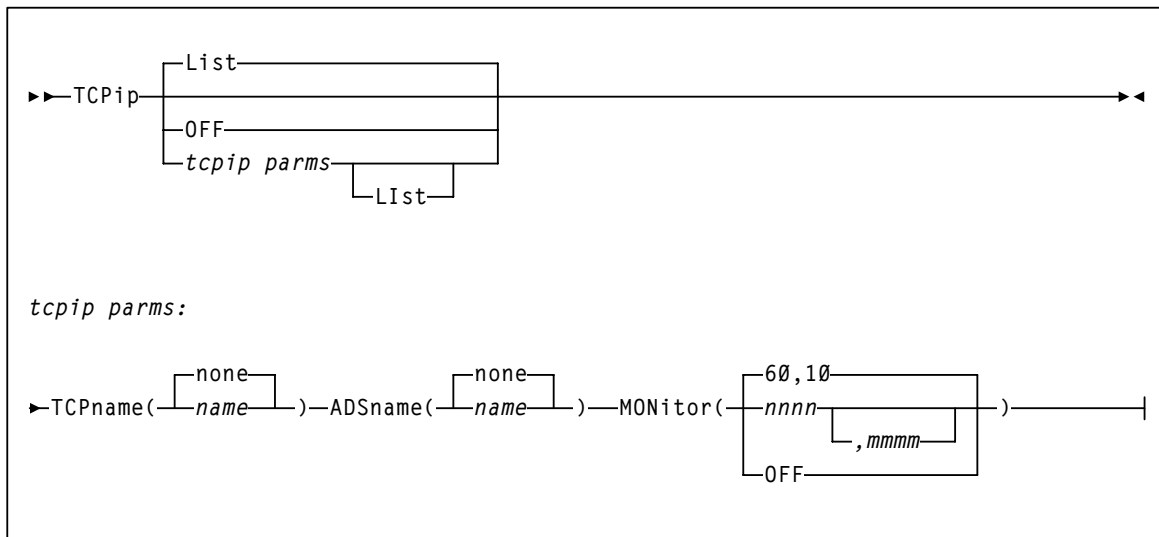

Command Name

TCPip

initiates the TCPip command

Parameter Descriptions

List

optionally, lists current TCPip command defaults.

- List is the default when **no** parameters are specified on the TCPip command.
- List may be specified with other parameters. In this case, the List is generated **after** the other parameters are processed.

OFF

optionally, specifies that system defaults are used for TCP/IP communications

TCPname

optionally, specifies the subsystem name or address space name of a specific TCP/IP stack on an MSP host

name

the subsystem name or address space name

- If a subsystem name is specified, it must consist of one to four alphanumeric or national (#,@,\$) characters, the first character being alphabetic or national.
- If an addressname is specified, it must consist of one to eight alphanumeric or national characters.

ADSname

optionally, specifies the ADSNAME value for a specific TCP/IP stack on an MSP host. ADSNAME is the jobname of the TCP/IP startup job. Refer to the Fujitsu publication *TCP/IP for MSP Application Programming Interface Reference* for more information about ADSNAME.

name

the ADSNAME value

MONitor

optionally, specifies the communication monitor subtask scan interval and communication monitor subtask message interval.

nnnn

indicates the monitor scan interval in seconds. The communication monitor wakes every *nn* seconds to perform library communication validation. Specify a value between 10 and 9999 or OFF. The default is 60. OFF disables the communication monitor subtask.

It is recommended that you preserve the default setting of 60 to enable a monitor scan every minute. A value that is too low can potentially degrade performance when inactive libraries exist. A value that is too high can delay a return to the primary server if PREFPRIMARY(ON) is specified, or delay the redriving of mounts when there is no allocation or mount activity but a communication path becomes available.

mmmm

optionally, indicates the monitor scan interval in number of scans. Communication error messages are displayed according to this interval. The default is 10.

The default MONITOR(60,10) setting specifies a monitor scan interval of 60 seconds, and a monitor message interval of 10 scans. A scan is performed every minute, but error messages are only produced once every 10 scans.

An *mmmm* value of 0 disables all non-fatal or non-disabling error messages issued by the communication monitor subtask. However, errors resulting in the disabling of a server communication path are still issued.

Example

In the following example, a TCPip command directs TCP/IP requests to a CA Unicenter TCPaccess TCP/IP stack.

```
TCP/IP TCPNAME (ACSS)
```

TRace Command

The SMC TRace command enables SMC tracing using the GTF trace facility and optionally provides a snap dump of the address space before and after control block modification.

Note – This command may impact system performance and should be used **only** as directed by StorageTek Software Support.

Syntax

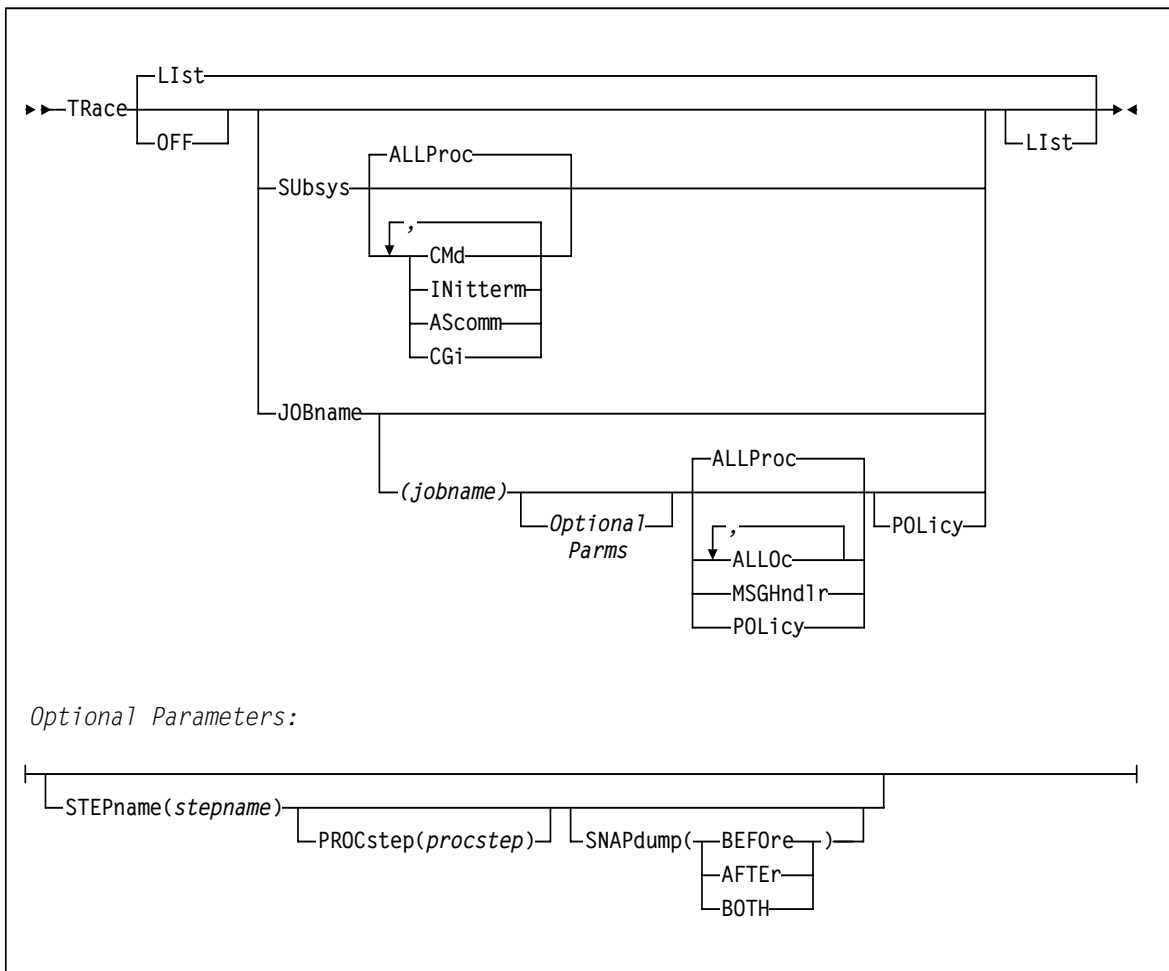

Command Name

TRace

initiates the TRace command

Parameter Descriptions

LlSt

optionally, lists current SMC trace settings for both the SMC subsystems and SMC components by job name, step name, and PROC step

- LlSt is the default when **no** parameters are specified on the TRace command.
- LlSt may be specified with other parameters. In this case, the LlSt is generated **after** the other parameters are processed.
- If no JOBname is specified, all jobs with SMC components being traced are listed.
- If JOBname is specified, **only** those jobs with SMC components being traced whose job name matches the specified job JOBname are listed.

OFF

optionally, disables SMC tracing

- If no other parameters are specified, tracing is disabled for all jobs.
- If only JOBname is specified, tracing is disabled for all entries for that job name.
- If JOBname, STEPname and PROCstep are specified, tracing is disabled **only** for the specified entry.

SUbsys

optionally, enables or disables SMC tracing for one or more SMC subsystem components or subtasks

ALLProc

optionally, enables tracing for the SMC operator command subtask, SMC initialization and termination subtask, and the SMC address space component. This is the default if no parameters are specified.

CMd

optionally, enables tracing for the SMC subtask that processes all SMC operator commands

INitterm

optionally, enables tracing for the SMC subtask that performs SMC initialization and termination

AScomm

optionally, enables tracing for the SMC address space component. Tracing of library and configuration requests is performed **only** if tracing is also enabled for the jobname making the request.

CGi

optionally, enables tracing to the log of the StorageTek HTTP server. Tracing of HTTP server requests is performed **only** if tracing is also enabled for the jobname making the request.

Note – CGi tracing is **not** automatically enabled when ALLProc is specified. It must be specifically requested.

JOBname

optionally, specifies a job name. If not specified, tracing information for all jobs is displayed.

jobname

a specific job name

The value entered **must** be one to eight characters in length. An asterisk (*) can be used as a wildcard when included as the last character. In this case, all jobs whose job names match the characters preceding the asterisk are traced or listed. To trace all jobs, specify TRACE JOB(*).

STEPname

optionally, specifies a step name

stepname

the step name

The value entered must be one to eight characters in length. This parameter is **only** valid if JOBname is also specified.

PROCstep

optionally, specifies a PROC step

procstep

the PROC step

The value entered **must** be one to eight characters in length. This parameter is **only** valid if JOBname and STEPname are also specified.

SNAPdump

optionally, requests a snap dump.

Note – A snap dump may impact system performance, and should be used **only** as directed by StorageTek Software Support.

BEFORe

requests a snap dump before allocation influencing

AFTEr

requests a snap dump after allocation influencing

BOTH

requests a snap dump both before and after allocation influencing

ALLProc

optionally, enables tracing for both the SMC allocation component and message handler component. This is the default if no parameters are specified.

ALLOc

optionally, enables tracing for the SMC allocation component that performs drive exclusion and drive prioritization.

MSGHndlr

optionally, enables tracing for the SMC message handler component that processes all MOUNT, DISMOUNT, and SWAP messages and issues robotic movement commands to the StorageTek TapePlex

POLicy

optionally, enables tracing of selected SMC POLicy name and selection criteria to the job log of the jobname specified in the TRace command for allocation and mount policies

Note – POLicy tracing is **not** automatically enabled when ALLProc is specified. It must be specifically requested.

Examples

In the following example, tracing is enabled for any job whose name begins with "TESTJOB."

```
TRACE JOBNAME=TESTJOB*
```

In the next example, the TRace command specifies that tracing is disabled for all SMC initiator processes and SMC subsystem subtasks.

```
TRACE OFF
```

In the next example, tracing is enabled for SMC initiator allocation and message handling processes for any job with jobname ABC.

```
TRACE JOBNAME=ABC ALLOC MSGHN
```

In the next example, tracing is enabled for the SMC subsystem command component.

```
TRACE SUBSYS CMD
```

In the next example, tracing is disabled for all SMC subsystem subtasks.

```
TRACE SUBSYS OFF
```

In the next example, tracing is disabled for all jobs whose job name begins with "PROD."

```
TRACE OFF JOBNAME=PROD*
```

TREQDef Command

The TREQDEF command specifies and loads the definition data set containing your tape request (TAPEREQ) parameter statements.

This command may be issued from the SMCPARMS or SMCCMDS data set, or it may be issued by an operator.

Syntax

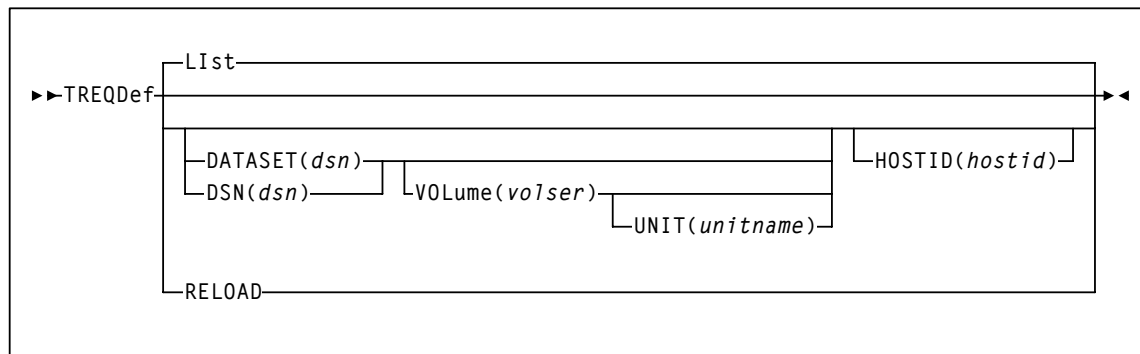

Command Name

TREQDef

initiates the TREQDef command

Parameter Descriptions

List

lists information about the definition data set containing TAPEREQ control statements that are currently loaded. Information includes:

- Data set name
- Member name
- Identifying string (if the data set contains an OPTION TITLE statement)
- Date and time parameters were loaded

List is the default when **no** parameters are specified on the TREQDef command.

DATASET or DSN

optionally, specifies the name of the data set containing the TAPEREQ control statements to be processed and, optionally, an OPTion TITLE statement

dsn

the data set name

This data set can be a fixed length 80-byte sequential data set, or a fixed length 80-byte member of a PDS. If the data set name includes a member name, you must enclose the *dsn* in quotes. For example:

```
DATASET ( ' YOUR . PDS . DSN (MEMBER) ' )
```

VOLume

optionally, specifies the volume serial number of the DASD volume on which the data set resides. Specify this parameter if the data set is not catalogued.

volser

the volume serial number

UNIT

optionally, specifies the unit name of the specified VOLume for uncataloged data sets. Requires that VOLume also be specified

unitname

the unit name

If not specified, then a unit name of SYSALLDA is the default.

HOSTID

optionally, specifies the hostid from which to execute this control statement. This parameter is valid only for use in PARMLIB, to allow multiple systems to share a parmlib member containing multiple TAPEREQ control statement members.

hostid

the host name(s) from which to execute this control statement. Multiple host names must be separated by commas.

RELOAD

optionally, reloads the currently loaded TAPEREQ control statements from the same data set. This parameter can be used after a TREQDEF DSN(*dsn*) command is issued, and changes may then be made to the contents of that data set.

Example

In the following example, the TREQDEF command loads the TAPEREQ parameters from YOUR.DSN(MEMBER).

```
TREQDEF DSN ( ' YOUR . DSN (MEMBER) ' )
```

Command Name

UEXit

initiates the UEXit command

Parameter Descriptions

LlSt

optionally, displays status information for all user exits

- LlSt is the default when **no** parameters are specified on the UEXit command.
- LlSt may be specified with other parameters. In this case, the LlSt is generated **after** the other parameters are processed.

number

optionally, specifies the user exit number. Valid values are 1, 2, 3, 5, 6, 8, 9, 10, 14, and 15.

NAME

optionally, specifies the user exit's load module name

name

the load module name (e.g., SLSUX01)

FORMat

optionally, specifies the format of user exit to be enabled or disabled

HSC

the HSC user exit format

LOAD

optionally, loads the specified user exit, making it available for use

Note –

- If a user exit is not loaded, it **will not be** called.
 - A subsequent load of a module for the same user exit causes the currently active copy of the load module to be deleted when its use count reaches zero.
-

ENable

optionally, enables a user exit that was previously disabled due to a problem

DISable

optionally, disables a user exit to allow for problem resolution

Example

In the following example, the UExit command is used to load HSC user exit 01 (SLSUX01).

```
UEXIT 01 NAME(SLSUX01) FORMAT(HSC) LOAD
```

SLSUX01 is loaded from the SMC STEPLIB, JOBLIB, or your system's linklib concatenation.

UNITAttr Command

The SMC acquires drive type information from both the MSP operating system and the NCS library control systems (TapePlexes). For the HSC, data returned from configuration queries is used to augment information returned from the operating system for library-controlled devices.

The SMC UNITAttr command allows you to specify device addresses and attributes to augment operating system information for nonlibrary controlled devices, and effectively ignore configuration information from TapePlexes for specified devices when multiple TapePlexes define the same device address. The SMC UNITAttr command allows you to do the following:

- Set MODEL=IGNORE for device addresses not available for this host.
- Specify model types for nonlibrary devices on this host.
- Specify NOTAPEPlex for a nonlibrary device address or range that is defined to multiple TapePlexes, but for this host the attached devices belong to the specified TapePlex.
- Specify TapePlex ownership and model for devices that may be referenced by a mount after the SMC is started but before the TapePlex is initialized.

See [“SMC Drive Type Information Synchronization” on page 48](#) for configurations that may require or benefit from the use of UNITAttr commands.

Note –

- Existing HSC UNITATTR control statements are **not** disabled. However, UNITATTR statements for nonlibrary and MODEL(IGNORE) devices are only processed for remote SMC 6.0 client systems. HSC UNITATTR statements for library and virtual drives are **not** used in any HSC processing after release 6.0.
 - SMC does **not** support a UNITDEF command. Each UNITATTR command is parsed and processed independently.
 - HSC nonlibrary and MODEL=IGNORE UNITATTR statements are no longer returned to SMC on a configuration query. Therefore, if you use UNITAttr to bypass devices for allocation or to define the device type of nonlibrary drives, you must define these UNITATTR commands to the SMC subsystem.
-

Syntax

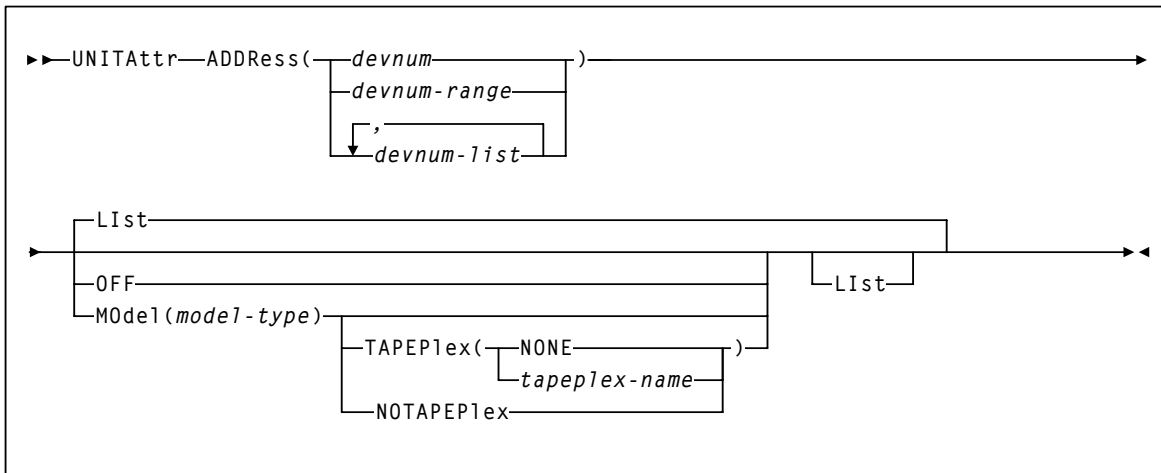

Command Name

UNITAttr

initiates the UNITAttr command

Parameter Descriptions

ADDRESS

specifies the device numbers to be processed by the UNITAttr command

devnum, *devnum-range*, *devnum-list*

the device number, device number range, or device number list

List

lists the UNITAttr model information for the device numbers specified by the ADDRESS parameter

OFF

optionally, specifies that the model type for the device numbers specified by the ADDRESS parameter should be determined from the device UCB, or, for a device which was previously set to MODEL=IGNORE, that the MODEL information from the library server should be restored

MOdel

optionally, specifies the model type of the transport to be assigned the device numbers specified by the ADDRESS parameter

model-type

the model type

See TABLE B-5 on page 292 for a list of valid *model-type* values.

TAPEPlex

optionally, specifies the name of a TapePlex to be associated with the drive before communication is established

TapePlex-name

the TapePlex name.

If specified, this name must match a TapePlex name defined in a TAPEPlex command.

NONE

optionally, removes the TapePlex association from the specified device addresses

NOTAPEPlex

optionally, specifies that the specified address or address range are nonlibrary devices, even when configuration queries from NCS library control systems indicate that the device is library controlled. Use this parameter when a local nonlibrary device address overlaps a TapePlex owned device that is not accessible from his host.

Note –

- When a MOdel is specified with TAPEPlex, the configuration query model information returned from the TapePlex is assumed to be the “real” or “correct” model, and it overrides any MOdel specified in the UNITAttr command.
- If TAPEPlex is specified for an address, but that address is not returned from the configuration query for that TapePlex, an error message is issued, but the erroneous TapePlex ownership remains with the specified device address. As a result, any mounts destined for the specified device address are not automated and are rejected by the specified TapePlex.

Example

In the following example, nonlibrary model 9840C devices are defined.

```
UNITATTR ADDR(2910,2911) MODEL(T9840C)
```

USERMsg Command

The USERMsg command allows you to specify additional message identifiers for messages to be intercepted and passed to the library subsystem's user exit 01. This command can also be used to list the message identifiers of those messages that have been defined using the USERMsg command.

Syntax

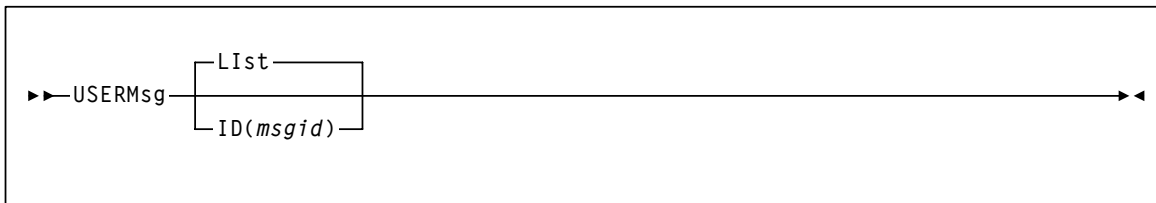

Command Name

USERMsg

initiates the USERMsg command

Parameter Descriptions

LIst

optionally, lists the message identifiers in the customer-defined message table. This is the default if no parameters are specified.

ID

optionally, specifies a message to be added to the customer-defined message table. This message is passed to user exit 01.

msgid

indicates the message identifier for the message to be added.

Note – This parameter may **only** be specified in the SMCPARMS data set.

Example

In the following example, the USERMsg command is used to list message identifiers for messages included in the customer-defined message table.

```
USERMSG LIST
```

Recovery Procedures

Overview

This chapter describes recovery procedures used when the SMC or a TapePlex becomes inactive.

SMC Recovery Procedures (JES)

This section describes recovery procedures for the following problem scenarios:

- Inactive SMC - active TapePlex
- Active SMC - inactive TapePlex
- Automating mount requests for inactive TapePlexes
- Lost MSP mount requests for active TapePlexes

Inactive SMC - Active TapePlex

When the SMC fails while one or more TapePlexes remain active, the following functions are **not** performed:

- Allocation processing
- Automation of mount/dismount/swap messages

When this occurs, re-start the SMC.

Certain software products allow you to suspend processing that may require dynamic allocation.

Common allocations can be postponed by holding the job queue or purging all initiators. Refer to the appropriate Fujitsu publication for more information about JES operator commands.

If the SMC MOUNTDef AUTOPendmount (ON) option was specified, outstanding mount messages are re-driven.

Active SMC - Inactive TapePlex

When a TapePlex fails or is terminated, volumes and drives owned by that TapePlex become unknown to SMC. The following functions are **not** performed:

- Volume lookup for allocation influencing
- Automated mount processing

When this occurs, re-start the TapePlex and issue the SMC RESYNC command. The SMC re-establishes communication with the TapePlex and automates any outstanding mounts, regardless of the SMC MOUNTDef AUTOPendmount setting. See [“Automating Mount Requests for Inactive TapePlexes”](#) below for more information.

Certain software products allow you to suspend processing that may require dynamic allocation.

Common allocations can be postponed by holding the job queue or purging all initiators. Refer to the appropriate Fujitsu publication for more information about JES operator commands.

Note – You can provide a backup path to a remote TapePlex that is automatically activated when the local HSC is discovered to be inactive. See [Chapter 2, “SMC and StorageTek TapePlex Management”](#) for more information.

Automating Mount Requests for Inactive TapePlexes

MSP mount requests for drives owned by inactive TapePlexes are automatically redriven when the corresponding TapePlexes are activated.

Lost MSP Mount Requests for Active TapePlexes

An MSP mount request may be lost when an LMU error occurs. Use this procedure if you suspect lost mounts.

1. Issue the following MSP command on the system requesting the mount to determine if any drives have a mount request pending:
 D R,L
2. Issue the following MSP command on the same system to determine which VOLSER to mount:
 D U, , ,uuuu,1
3. If the drive is defined to an HSC TapePlex, issue the HSC Mount command for the volume on the MSP system on which the HSC is active.

Utilities

Overview

This chapter provides information for the following SMC utilities:

- Tape Management Extract utility (SMCUDBX), used to support scratch synchronization between the SMC client host and the HSC CDS
- Unified User Interface utility (SMCUUI), used to issue HSC Unified User Interface (UI) commands, VTCS commands, or SMC commands from a batch job
- POLicy and TAPEREQ Batch Test utility (SMCUTRQ), used to test POLicy and TAPEREQ lookup.

SMC Utility Return Codes and Messages

SMC utilities may return the following return codes:

- A return code of 0 is returned when the utility program completes successfully with no errors or warnings.
- A return code of 4 is returned when a warning message is detected.
- A return code of 8 is returned when an error that prevents the utility from completing is detected.

For a listing of SMC messages that may be returned by SMC utilities, see [“SMC Utility Message Listing” on page 256](#). These messages are identified by the SMCU prefix.

Tape Management Extract Utility (SMCUBX)

The SMC utility SMCUBX supports scratch synchronization between the SMC client host and the HSC CDS. Using common tape extract modules (SLUDRCA1, SLUDRTL, and SLUDRZAR) with HSC, the SMC accesses the client tape management system to produce an extract file that can be read as input by the HSC scratch tape conversion module SLUCONDB. This process is illustrated in the following figure:

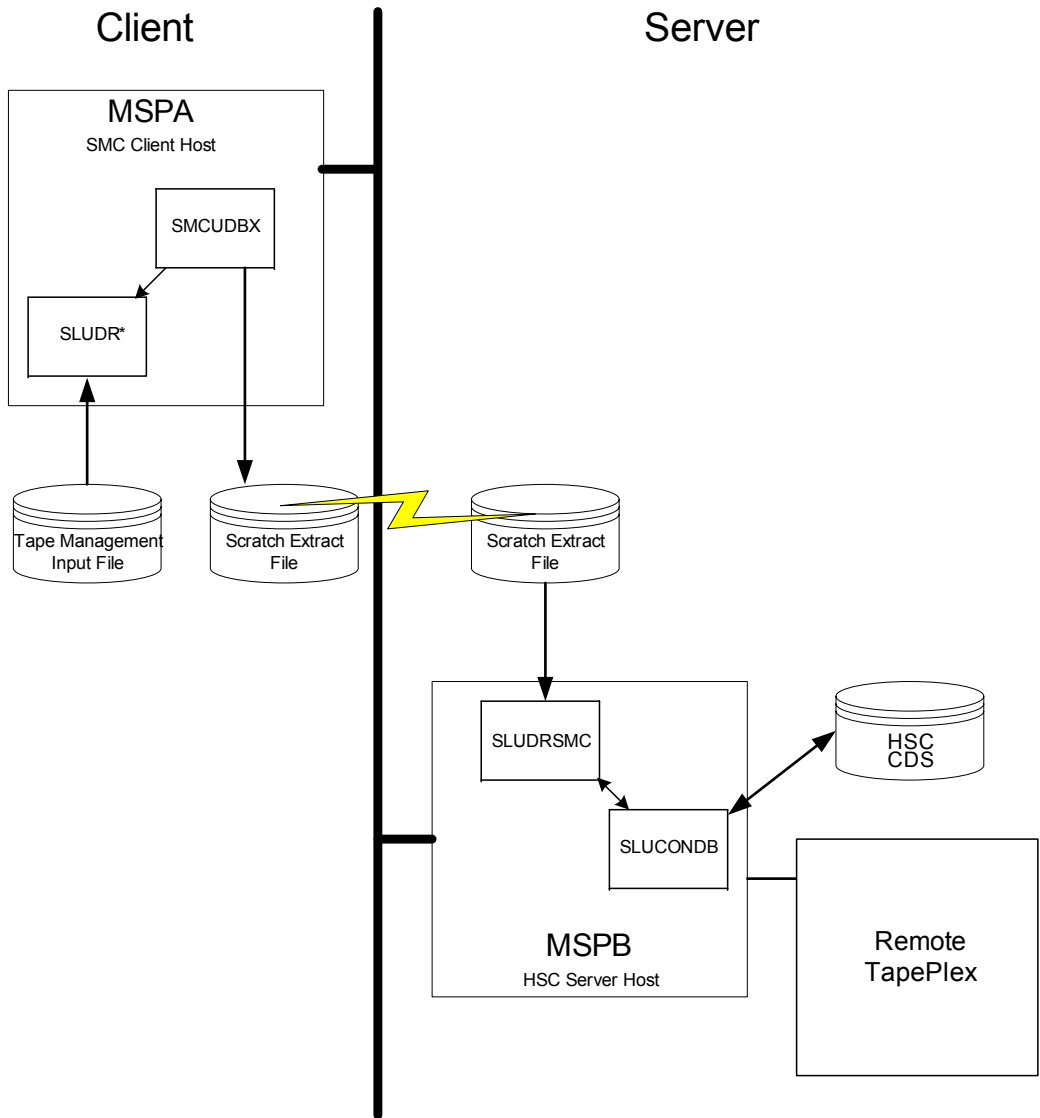

FIGURE 9-1 Scratch Synchronization Between SMC Client host and HSC CDS

If the client and server share a tape management system, the HSC utility SLUCONDB may be run directly using the common tape management system data base as input.

If, however, the client host has a tape management system that is not accessible to the HSC host, the SMC utility SMCUDBX can be used to extract scratch volumes from the tape management system using label and date parameters. The SMCUDBX output can then be used as input on the HSC host to the SLUCONDB utility. The SMC process supports timing synchronization by comparing the GMT time of the SMCUDBX run with the last select time of the HSC CDS volume record. If the volume was selected after the SMC scratch run, it is not eligible for scratch by SLUCONDB.

Running the SMC Scratch Extract Utility

You can run the SMC scratch extract utility regardless of whether the SMC is executing on the host.

SMCUDBX processes the CA-1 Tape Management Catalog (TMC), the CA-DYNAM/TLMS Volume Master File (VMF), or the Zara database, and selects the volume serial numbers for processing based on information specified on the PARM parameter of the JCL EXEC statement.

For CA-1 and CA-DYNAM/TLMS, SMCUDBX calls the appropriate tape management system database READ routine. For Zara, SMCUDBX invokes the SLUDRZAR module, which in turn invokes an application programming interface (API) to read Zara's database. The data returned from these routines is used to format the SMC scratch extract file.

The following list describes the READ routines that are called for the CA-1, CA-DYNAM/TLMS, and Zara tape management systems.

SLUDRCA1

Called to read the CA-1 TMC when CA-1 is defined as the tape management system. This routine uses CA-1 macros to map the layout of the TMC.

SLUDRTLM

Called to read the CA-DYNAM/TLMS VMF when CA-DYNAM/TLMS is defined as the tape management system. This routine uses a CA-DYNAM/TLMS COPY member to map the layout of the VMF.

SLUDRZAR

Called to invoke an API to read Zara's database when Zara is defined as the tape management system.

Note – Both source and load module versions of the SLUDR* tape management extract routines are provided as part of the SMC product installation. Source modules are provided in the SMC SAMPLIB file and load modules are provided in the SMC SLULINK distribution library.

If your installation uses a different tape management system, you can develop a program modeled on one of the supplied examples SLUDRCA1, SLUDRTL, or SLUDRZAR, or you can write your own program to produce an extract file in the following format:

Position	Field	Format
1	Scratch volume	CL6
7	GMT of run	XL8
15	Unused	CL2

The time filed in the SMC scratch extract file is a character representation of the first four bytes of the output of the MSP STCK macro. For example, if the STCK macro produces a result of X'B0912345 6789ABCD', the GMT field of the SMC extract contains the character value C'B0912345'.

SMCUDBX, SLUDRCA1, SLUDRTL, and SLUDRZAR are provided as load modules. You can use the current versions of these load modules with CA-DYNAM/TLMS Release 5.4 and above, CA-1 Release 5.0 and above, and Zara 1.2. The HSC SAMPLIB file on the NCS base tape contains the sample source code.

Note –

- If there are local modifications to your tape management system, you must reassemble the associated READ routine.
 - If your tape management system is CA-1 Release 4.9 or below, you must modify and reassemble the SLUDRCA1 routine. See [“Using SMCUDBX with CA-1 Release 4.9 or Below” on page 185](#) for information about modifying and reassembling this routine.
 - If your tape management system is CA-DYNAM/TLMS Release 5.3 or below, you must reassemble the SLUDRTL routine. See [“Using SMCUDBX with CA-DYNAM/TLMS Release 5.3 or Below” on page 185](#) for information about reassembling this routine.
 - If your tape management system is Zara, the SMCUDBX utility must be able to access the data set that contains the Zara API module (ZARAAPI1). You can either store this module in the LINKLIST, or include a JOBLIB or STEPLIB DD statement in the SMCUDBX JCL that points to the library containing the module.
 - Any routine that you modify and reassemble must be re-linked as non-reentrant (NORENT parameter) with AMODE=24 and RMODE=24.
-

Using SMCUDBX with CA-1 Release 4.9 or Below

To use SMCUDBX with CA-1 Release 4.9 or below, you must modify and reassemble the SLUDRCA1 routine. The CA-1 MACLIB containing the TMRECORD MACRO must be accessible during the assembly.

Perform the following steps for CA-1 Release 4.9:

1. Delete the asterisk in column 1 of the following line:

```
TMRECORD
```

2. Add an asterisk in column 1 of the following line:

```
TMMTMREC
```

3. Reassemble the SLUDRCA1 routine.

Using SMCUDBX with CA-DYNAM/TLMS Release 5.3 or Below

Perform the following steps to use SMCUDBX with CA-DYNAM/TLMS Release 5.3 or below:

1. Verify that the CA-DYNAM/TLMS Release 5.3 MACLIB containing the VMFBASE MACRO is accessible for the re-assembly of the SLUDRTL routine.
2. Reassemble the SLUDRTL routine; no modifications to the source code are required.

Specifying Values for the PARM Parameter

You can specify the following values for the PARM parameter on the JCL EXEC statement when running the Scratch Extraction utility.

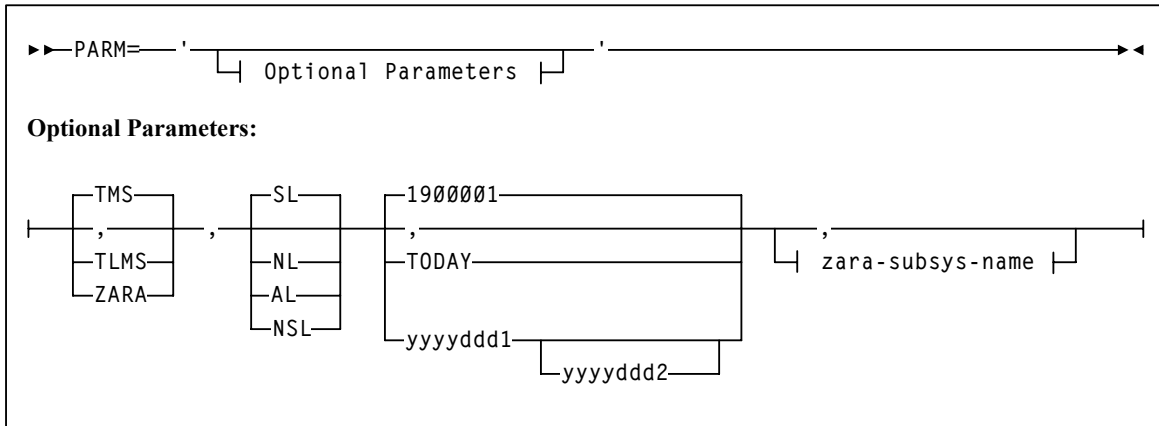

The keywords for the PARM parameter are positional. If the PARM parameter is not specified, default values are used.

Parameter Descriptions

This section describes the values you can specify for the PARM parameter on the JCL EXEC statement.

TMS

Specifies the CA-1 tape management system.

This is the default value.

TLMS

Specifies the CA-DYNAM/TLMS tape management system.

ZARA

Specifies the Zara tape management system.

SL

specifies standard label type for the scratch volume selection. This is the default value.

NL

specifies nonlabeled type for the scratch volume selection.

AL

specifies ANSI label type for the scratch volume selection.

NSL

specifies nonstandard label type for the scratch volume selection.

1900001

Specifies January 1, 1900 as the date. This is the default date.

Note – You must specify a four-year format for year 2000 dates. For example, specify 2000001 for January 1, 2000.

TODAY

Specifies the current system date.

yyyyddd1

Specifies a single date in four-year format. This date becomes the *from* date. The *to* date is the current system date (which is not specified). All dates must be specified in Julian notation (year-day).

yyyyddd1-yyyyddd2

Specifies a range of dates in which the volumes became scratch. Neither date specified can be greater than the current system date, and the first date cannot be greater than the second date.

Note – A comma (,) or no keyword (blank) results in the system default date of January 1, 1900 (1900001).

MIXED

Specifies to print all report headings and messages in mixed-case characters (uppercase and lowercase).

Note – A comma (,) or no keyword (blank) results in headings and messages being printed in uppercase characters.

zara-subsys-name

Specifies the subsystem name for the Zara tape management system, where *zara-subsys-name* is the four-character name. The default subsystem name is ZARA.

Sample JCL

The following definitions apply to the JCL used for the SMC Scratch Extract utility.

DBTMS

Input to the Scratch Extract utility in the form of the CA-1 TMS or the CA-DYNAM/TLMS VMS. This DD statement is not required for Zara.

STDOUT

Output messages from the Scratch Extraction utility. This DD statement is required.

DBEXTFIL

Output file from the Scratch Extract Utility. If a DCB LRECL is specified, it must specify a 16-byte value.

If Zara is the tape management system, the Zara API module must either reside in the MSP LINKLIST, or you must include one of the following JCL statements to access the module.

```
//STEPLIB DD DISP=SHR, DSN=your.zaraapi.library
           DISP=SHR, DSN=your.tmsextract.library
           or
//JOB LIB DD DISP=SHR, DSN=your.zaraapi.library
```

The following figure shows sample JCL used to invoke the Scratch Extraction utility to process the CA-DYNAM/TLMS VMF for all tapes scratched in 2003.

```
//yourstd JOB card
//STEP0 EXEC PGM=SMCUDBX,PARM='TLMS,,2003001-2003365'
//STEPLIB DD DISP=SHR,DSN=your.SMCLINK
//          DD DISP=SHR,DSN=your.SLU DRxxx.LINKLIB
//DBTMS DD DISP=SHR,DSN=your.tlms.database
//DBEXTFIL DD DISP=(NEW,KEEP),DSN=scratch.extract.file,
//          SPACE=(TRK,(5,1)),UNIT=SYSDA
//STDOUT DD SYSOUT=*
/*
```

FIGURE 9-2 Sample JCL for Scratch Extraction Utility

Sample Output

Scratch Extraction utility output includes the following:

- Messages associated with error conditions resulting from an unsuccessful attempt to execute scratch extraction processing
- Messages indicating errors or actions occurring during processing
- Output data set containing Scratch Update utility control statements

The following figure shows sample output from the SMCUDBX utility.

```
SMCUDBX 6.2.0          SMC TMS DB SCRATCH EXTRACT          Page 0001
TIME 15:26:41                                     Date 2006-08-14

Total records extracted for scratch volumes = 977
```

FIGURE 9-3 Scratch Extraction Utility Sample Output Messages

SMCUUUI Utility

The SMC utility SMCUUUI is used to issue SMC and HSC Unified User Interface (UI) commands, or VTCS requests from a batch job. The commands can be routed to a local or remote HSC TapePlex. Several types of output can be received for a UI command, including:

- **Plain text output**

This type of output is written to TEXTOUT, and corresponds to the normal output produced by the HSC or VTCS command or report utility. If plain text output is requested for an HSC or VTCS report, the report headings are **not** produced by the UI.

- **Structured XML**

This type of output is written to XMLOUT. Structured XML is a well formed XML data stream with XML header tags and XML data tag elements, and XML data element content. The complete list of SMC, HSC and VTCS XML tag names and types is listed in the *NCS/VTCS XML Guide*.

- **Comma Separated Values (CSV)**

This type of output is written to CSVOUT. An input template of XML data tag names is used to define the format of the CSVOUT corresponding to a particular request. The output data for each request is a CSV header line that contains a comma-separated list of the XML data tags requested, followed by CSV detail lines. Each CSV detail line contains one comma-separated entry for each requested XML data tag. This type of output is readily adaptable as input into spreadsheets or customized report writers. Refer to the *NCS/VTCS XML Guide* for more information about the format for specifying CSV.

The type of output received is controlled by the data set definition statements (DD) defined in the JCL to execute the SMCUUUI utility.

Note – In general, error messages are **not** produced for CSV output. To view error messages produced by the UI process, you **must** include either a TEXTOUT or XMLOUT DD statement.

Sample JCL

The following JCL sample executes the SMCUUUI utility.

```
//yourstd JOB card
//STEP EXEC PGM=SMCUUUI, PARM='pgmparms'
//STEPLIB DD DSN=yoursmc.LINKLIB, DISP=SHR
//          DD DSN=yourvtcs.LINKLIB, DISP=SHR
//          DD DSN=yourhsc.LINKLIB, DISP=SHR
//STDOUT DD DSN=yourstd.printout.dataset, DISP=SHR
//UUIIN DD *
  CSV and uui commands
//*****
//* Specify at least one of the following output data sets:      *
//*****
//CSVOUT DD DSN=yourcsv.output.dataset, DISP=SHR
//XMLOUT DD DSN=yourxml.output.dataset, DISP=SHR
//TEXTOUT DD DSN=yourtext.output.dataset, DISP=SHR
```

FIGURE 9-4 JCL to Execute the SMCUUUI Utility

Parameters

The following SMCUUUI utility parameters may be specified for *pgmparms* in the sample JCL:

TAPEPlex(name)

Specifies the name of the SMC TapePlex to which the UUI commands will be directed. If omitted, the first active TapePlex found is used.

Use TAPEPlex(SMC) to indicate that the input commands are to be issued directly to the SMC, and not to a TapePlex (such as the SMC Display Volume and Display DDrive command).

XMLDate(format)

Specifies the format of the returned date fields in the XML and CSV output.

Valid date formats and examples are as follows:

- **YYYYMONDD** (default format)
Example: 2006Aug13 for August 13, 2006
- **YYYY-MM-DD**
Example: 2006-08-13 for August 13, 2006
- **YYYY-MON-DD**
Example: 2006-Aug-13 for August 13, 2006

Required Data Set Definition (DD) Statements

You must specify the UUIIN and STDOUT data set definitions.

UUIIN Data Set

The UUIIN data set contains:

- SMC UUI commands
- HSC UUI commands
- VTCS PGMI requests

Native SMC UUI commands include Display DRive and Display Volume.

Refer to the *NCS/VTCS XML Guide* for a list of supported HSC UUI requests. Syntax rules for UUI input are as follows:

- Input must be 80 byte card images.
- Only columns 1-72 of the 80 byte card image may contain actual command input. Columns 73-80 may be used for sequence numbers if desired.
- If the last non-blank character in columns 1-72 is a "+", the logical command is continued on the next physical card.
- Comments begin with "/*" (in column 2 or beyond) and end with "*/".
- The maximum logical command length is 32000 bytes.

STDOUT Data Set

The STDOUT data set is where the SMCUUI utility reports the input and final completion code for each UUI request.

Output Data Set Definition (DD) Statements

You **must** specify at least one of the following output data set definition statements:

- XMLOUT
- CSVOUT
- TEXTOUT

XMLOUT Data Set

The XMLOUT data set is where the SMCUUUI utility outputs the structured XML output corresponding to the UUIIN command, as shown in the following example:

```
//yourstd JOB card
//STEP EXEC PGM=SMCUUUI
...
//UUIIN DD *
SCRATCH VOL(400720)
//XMLOUT DD DSN=yourxml.output.dataset,DISP=SHR
...
```

The XMLOUT DD would contain the following output:

```
<scratch_request>
<header>
<hsc_version>6.2.0</hsc_version>
<date>2006Apr19</date>
<time>13:54:34</time>
<host_name>MSPB</host_name>
</header>
<volume_data>
<volser>400720</volser>
<result>success</result>
<reason>SLS0167I Volume 400720 successfully added to library as
scratch
</reason>
</volume_data>
</scratch_request>
```

CSVOUT Data Set

The CSVOUT data set is where the SMCUUUI utility writes the CSV output for the requested UUIIN commands that specified corresponding CSV formatting. Refer to the *NCS/VTCS XML Guide* for a complete explanation of the Comma Separated Value (CSV) specification.

The maximum logical CSV input length is 4096 bytes.

Note – In general, error messages are **not** produced for CSV output. To view error messages produced by the UUI process, you **must** include either a TEXTOUT or XMLOUT data set definition statement.

TEXTOUT Data Set

The TEXTOUT data set is where the SMCUUUI utility outputs plain text UUI responses. This is the same output that would be received from the corresponding SMC, HSC or VTCS command, or written to the SLSPRINT DD by the SLUADMIN or SWSADMIN utility, except that page and column headings are not produced. This data set is optional.

POLicy and TAPEREQ Batch Test Utility (SMCUTRQ)

The SMC utility SMCUTRQ is used to test SMC tape policy lookups. The program accepts control cards containing the same type of information that is extracted by the SMC during tape allocation and mount processing.

After you input the jobname, stepname, program name and other attributes on the control cards, this utility formats those attributes and requests SMC tape policy lookups from the SMC subsystem as if it were a job with those simulated characteristics.

Next, the utility generates a report indicating what policy was matched, or what TREQDef TAPEREQ statements, if any, were matched for the specific criteria. If the currently active TREQDef file is accessible, as indicated by the TREQDef LList command, the actual TAPEREQ statements matching each lookup are listed.

The SMCUTRQ utility requires an active SMC subsystem on the same host. If SMC is not active, an error message is produced and the program terminates.

Sample JCL

Execute load module SMCUTRQ in the SMC linklib to produce the report.

The following JCL sample executes the SMCUTRQ utility:

```
//yourstd JOB card
//STEP EXEC PGM=SMCUTRQ
//STEPLIB DD DSN=yoursmc.LINKLIB,DISP=SHR
//STDOUT DD DSN=yourstd.printout.dataset,DISP=SHR
//SYSOUT DD SYSOUT=*
//SMCIN DD *
POL1 jobname stepname pgmname ddname nnnn yyyy/ddd mgmtclas
POL2 C volser dataset.name
```

FIGURE 9-5 JCL to Execute the SMCUTRQ Utility

Control Cards

Each TAPEREQ POLicy lookup requires that you enter two control cards specifying the job step characteristics to be simulated. The control card format is as follows:

Card 1:

Column	Length	Field	Format
1	4	ID	"POL1" required identifier
6	8	jobname	1-8 character non-generic jobname
15	8	stepname	1-8 character non-generic stepname
24	8	program name	1-8 character non-generic program name
33	8	ddname	1-8 character non-generic ddname
42	4	retention period	4 digit retention period
47	8	expiration date	yyddd, yyyyddd, or yyyy/ddd format expiration date
56	8	management class	1-8 character non-generic SMS management class name

Card 2:

Column	Length	Field	Format
1	4	ID	"POL2" required identifier
6	1	volume type	"S" for specific "N" for non-specific (scratch)
8	6	volume serial	6 character volser
15	44	dataset name	44 character non-PDS MSP dataset name

Note –

- All variable length fields must be left justified.
- Retention period and expiration date fields are mutually exclusive. When both are specified, retention period is used.
- You may ignore the lookup fields that are not important to your lookup. This is determined by looking at what selection criteria you actually use on your TAPEREQ statements. However, it is recommended that you specify all non-mutually exclusive fields.
- "POL1" and "POL2" control cards are required, even if all input fields are not coded.
- You can input multiple sets of control cards.

Sample Input

Example 1

```
POL1 TSTNEWPG STEP1      TESTPGM  MYTAPE1
POL2 S 123456 ABC.QUAL1.QUAL2.TEST
```

Simulate the TAPEREQ lookup that would occur when:

- Specific volume 123456 for DSN ABC.QUAL1.QUAL2.TEST
- Allocated to DD MYTAPE1 for job TSTNEWPG, step STEP1, executing program TESTPGM.

Example 2

```
POL1 TSTNEWPG STEP1      TESTPGM  MYTAPE1  0099
POL2 N          ABC.QUAL1.QUAL2.TEST
```

Simulate the TAPEREQ lookup that would occur when:

- Scratch volume for DSN ABC.QUAL1.QUAL2.TEST
- Allocated to DD MYTAPE1 with a retention period of 99 days
- For job TSTNEWPG, step STEP1, executing program TESTPGM.

Sample Output

```

SMCUTRQ 6.2.0                SMC POLICY/TAPEREQ TEST
Time 11:25:49                POLICY/TAPEREQ Lookup Report

SMCU0019 SMC subsystem=SMC0

Card 0001: *OL1|JOBNAME|STEPNAME|PGMNAME|DDNAME|RETP|EXPDT
Card 0002: *OL2|T|VOLSER|DSN
Card 0003: POL1 ANYJOB STEP1 TESTPGM DD1
Card 0004: POL2 S 123456 ABC.QUAL1.QUAL2.TEST

TAPEREQ lookup keys:
      JOBname=ANYJOB  STEPname=STEP1  PROGname=TESTPGM  DDname=DD1
      VOLType=S      VOLSer=123456   DSN=ABC.QUAL1.QUAL2.TEST

      Lookup for POLICY          not matched
      Lookup for RECTECH/MEDIA  matched TREQDEF record 5
      Statement: TAPEREQ DSN(ABC.**.TEST) MEDIA(VIRTUAL)
      Lookup for SUBPOOL        not matched
      Lookup for ESOTERIC       not matched
      Lookup for DEVTPREF       not matched

Card 0005: POL1 ANYJOB ANYSTEP ANYPGM DD1
Card 0006: POL2 S 123456 ABC.D11.XYZ.ABC

TAPEREQ lookup keys:
      JOBname=ANYJOB  STEPname=ANYSTEP  PROGname=ANYPGM  DDname=DD1
      VOLType=S      VOLSer=123456   DSN=ABC.D11.XYZ.ABC

      Lookup for POLICY          not matched
      Lookup for RECTECH/MEDIA  matched TREQDEF record 10
      Statement: TAPEREQ DSN(**.XYZ.***) MEDIA(VIRTUAL)
      Lookup for SUBPOOL        not matched
      Lookup for ESOTERIC       not matched
      Lookup for DEVTPREF       not matched

Processing complete; RC=0

```

FIGURE 9-6 SMCUTRQ Utility Sample Output

Messages

Overview

This chapter provides information about SMC messages and return codes. This information is provided to help system programmers and operators:

- Initialize the SMC.
- Monitor SMC activity.
- Diagnose and correct SMC problems.

See [Chapter 12, “Using the StorageTek HTTP Server”](#) for information about messages issued by the StorageTek HTTP Server for MSP.

Message Format

Messages are displayed on the console in the following format:

SMC***nnnn*** *message-text*

where:

- SMC identifies the Storage Management Component (SMC).
- *nnnn* is the four-character message number.
- *message-text* is the actual text displayed on the job log or system log.

Message Descriptions

This chapter provides a description for each SMC message. In addition to the message number and message text, this description includes the following:

Message Level

The message level represents a message category. Using the MSGDEF or MSGJOB operator command, the message level is specified in order to control which categories of messages are issued. See “MSGDef Command” on page 117 for more information.

Explanation

The explanation describes the message.

System Action

The system action describes how the SMC reacts when a message-triggering event occurs.

User Response

The user response describes how the user should respond to the message. In many cases, no response is required.

Variable Definitions

Italicized text indicates variable data that is replaced by actual values when messages are issued. Message specific variable data is symbolized as follows:

TABLE 10-1 Variable Data Definitions

Variable Data	Definition
<i>AA</i>	ACSid
<i>n</i>	decimal value
<i>X</i>	hexadecimal value
various letters (<i>C, N, K</i> , etc.)	variable information (character data)
numbers (<i>1, 2</i> , etc.) (combined with letters)	related variable information i.e., commands <i>CCCCCCCC1</i> and <i>CCCCCCCC2</i>
{ }	multiple choices
[]	optional field (may not appear in message)

Message Change Summary

The following SMC messages have been added, changed, or deleted in this release:

Note – See [Chapter 12, “Using the StorageTek HTTP Server”](#) for information about StorageTek HTTP Server messages.

New Messages

New System Messages

- | | | | |
|-----------|-----------|-----------|-----------|
| ■ SMC0000 | ■ SMC0181 | ■ SMC0192 | ■ SMC0207 |
| ■ SMC0092 | ■ SMC0182 | ■ SMC0193 | ■ SMC0208 |
| ■ SMC0172 | ■ SMC0183 | ■ SMC0194 | ■ SMC0226 |
| ■ SMC0173 | ■ SMC0184 | ■ SMC0195 | ■ SMC0241 |
| ■ SMC0174 | ■ SMC0185 | ■ SMC0196 | ■ SMC0242 |
| ■ SMC0175 | ■ SMC0186 | ■ SMC0197 | ■ SMC0243 |
| ■ SMC0176 | ■ SMC0187 | ■ SMC0200 | ■ SMC0260 |
| ■ SMC0177 | ■ SMC0188 | ■ SMC0201 | ■ SMC0261 |
| ■ SMC0178 | ■ SMC0189 | ■ SMC0202 | |
| ■ SMC0179 | ■ SMC0190 | ■ SMC0203 | |
| ■ SMC0180 | ■ SMC0191 | ■ SMC0204 | |

New Utility Messages

- | | |
|------------|------------|
| ■ SMCU0014 | ■ SMCU0020 |
| ■ SMCU0015 | ■ SMCU0021 |
| ■ SMCU0016 | ■ SMCU0022 |
| ■ SMCU0017 | ■ SMCU0023 |

Changed Messages

- | | | | |
|-----------|-----------|-----------|-----------|
| ■ SMC0048 | ■ SMC0118 | ■ SMC0136 | ■ SMC0172 |
| ■ SMC0049 | ■ SMC0128 | ■ SMC0137 | ■ SMC0173 |
| ■ SMC0099 | ■ SMC0130 | ■ SMC0138 | ■ SMC0175 |
| ■ SMC0101 | ■ SMC0131 | ■ SMC0139 | ■ SMC0203 |
| ■ SMC0104 | ■ SMC0132 | ■ SMC0142 | ■ SMC0204 |
| ■ SMC0106 | ■ SMC0133 | ■ SMC0143 | ■ SMC0207 |
| ■ SMC0116 | ■ SMC0134 | ■ SMC0154 | ■ SMC0226 |
| ■ SMC0117 | ■ SMC0135 | ■ SMC0167 | |

Deleted Messages

- SMC0104
- SMC0143

SMC System Message Listing

The following SMC messages are listed numerically.

SMC0000

{(CCCCCCCC)} command string

Level: 0

Explanation: The SMC received an input command from an operator console. The console name or user ID, if available, is listed followed by the command string.

System Action: None

User Response: None

SMC0001

SMC subsystem initializing

Level: 0

Explanation: The MSP start command was entered for the SMC, and the SMC subsystem initialization process has begun.

System Action: None.

User Response: None.

SMC0002

CCCCCCCCCCCCCCCC failed; return code=XXXX1, reason code=XXXX2

Level: 0

Explanation: MSP facility or macro CCCCCCCCCCCCCCCCCC completed with the specified nonzero return code XXXX1 and reason code XXXX2.

System Action: Depending upon the type of error, initiation/termination may try to continue. If the MSP facility is listed as *Requested SDUMP*, the error occurred during the TRACE SNAP process, and processing will continue without producing the requested SDUMP.

User Response: Look for Fujitsu related messages in the SYSLOG or job log, and refer to Fujitsu documentation for the explanation.

SMC0003

SMC subsystem SSSS terminating

Level: 0

Explanation: The MSP stop command was entered for the SMC, and the SMC subsystem termination process has begun.

System Action: None.

User Response: None.

SMC0004

MSP release is down-level

Level: 0

Explanation: An attempt was made to initialize the SMC on an MSP system that does not support the necessary services required by this version of SMC.

System Action: The SMC subsystem terminates.

User Response: Upgrade MSP to the required release level.

SMC0005

Invalid command CCCCCCCC [at line *nnnn* of SMCCMDS|SMCPARMS]

Level: 0

Explanation: An undefined command, CCCCCCCC, was encountered by the SMC.

System Action: Processing continues. The command is ignored.

User Response: Ensure that the syntax in the command data set is correct, or enter the corrected command.

SMC0006

SMC subsystem not dynamic

Level: 0

Explanation: The SMC was defined as a nondynamic subsystem using the positional form of the SUBSYSxx parmlib member. The SMC must run as a dynamic subsystem.

System Action: The SMC subsystem terminates.

User Response: Use the keyword format of the subsystem definition in the SUBSYSxx parmlib member to define the SMC subsystem, or remove the SMC subsystem from the SUBSYSxx parmlib member.

SMC0007

Explanation: SMCCVT incompatible with previous version; defaulting to COLD start

Level: 4

Explanation: During initialization, the SMC subsystem detected that the prior SMC subsystem of the same name was an incompatible version. The COLD start parameter was not specified.

System Action: Initialization continues, but in COLD start mode (the SMC subsystem CVT is rebuilt).

User Response: None.

SMC0008

Not running from an authorized linklib; SMC subsystem terminating

Level: 0

Explanation: The SMC subsystem initialization module, SMCBINT, was executed from an unauthorized library.

System Action: The SMC subsystem terminates.

User Response: Ensure that the SMC link library is APF authorized.

SMC0009

Job *JJJJJJJJ* JOB*nnnn* active at termination

Level: 4

Explanation: The SMC subsystem received the MSP stop ('P') command, but there is an active job, *JJJJJJJJ*, in tape allocation or message processing. The SMC0012 message was issued previously, but the job allocation or message processing has not completed after waiting one minute.

System Action: Termination continues. No allocation influencing is performed for the job, and mounts or dismounts will not be automated.

User Response: None.

SMC0010

Unable to acquire storage for *CCCCCCCC*; return code=*XXXX*

Level: 0

Explanation: During initialization, the SMC subsystem could not acquire sufficient storage for the specified dynamic control block or module, *CCCCCCCC*.

System Action: The SMC subsystem terminates.

User Response: Ensure that there is sufficient CSA storage available. Refer to Fujitsu documentation for the explanation of return code *XXXX*.

SMC0011

Load failed for module *MMMMMMMM*

Level: 0

Explanation: The SMC subsystem could not load the required module *MMMMMMMM*.

System Action: The SMC subsystem terminates.

User Response: Ensure that the SMC startup procedure has access to all SMC distributed load libraries in its steplib concatenation.

SMC0012

Termination waiting for job *JJJJJJJJ* JOB*nnnnnn* [in allocation|in message handling]

Level: 0

Explanation: The SMC subsystem received the MSP stop command, but there is an active job *JJJJJJJJ* in tape allocation or message handling.

System Action: The SMC waits for 30 seconds or until all active processes are complete.

User Response: Ensure that there are no jobs performing tape allocation or message handling when the SMC is terminated. Respond to any MSP allocation recovery messages.

SMC0013

TRACE settings:
CCCC....CCCC

Level: 0

Explanation: The TRACE command was specified with the LIST keyword. The SMC0013 multiline message lists the current settings for the SMC subsystem. Refer to the TRACE command for parameter descriptions.

System Action: None.

User Response: None.

SMC0014

Unmatched [quote|or invalid parenthesis] detected; command ignored [at line *nnnn* of SMCCMDS|SMCPARMS]

Level: 0

Explanation: The SMC encountered a command containing an unterminated quoted string, or invalid or unmatched parenthesis.

System Action: Processing continues. The command is ignored.

User Response: Ensure that the syntax in the command data set is correct, or enter the corrected command.

SMC0015

Invalid keyword *KKKKKKKK* for the *CCCCCCCC* command [at line *nnnn* of SMCCMDS|SMCPARMS]

Level: 0

Explanation: The SMC encountered a command that specified an invalid keyword *KKKKKKKK*.

System Action: Processing continues. The command is ignored.

User Response: Ensure that the syntax in the command data set is correct, or enter the corrected command.

SMC0016

Invalid value *VVVVVVVV* for keyword *KKKKKKKK* of the *CCCCCCCC* command [at line *nnnn* of SMCCMDS|SMCPARMS]

Level: 0

Explanation: The SMC encountered a command that specified keyword *KKKKKKKK* with an invalid value *VVVVVVVV*.

System Action: Processing continues. The command is ignored.

User Response: Ensure that the syntax in the command data set is correct, or enter the corrected command.

SMC0017

Keyword *KKKKKKKK* of the *CCCCCCC* command requires a value [at line *nnnn* of *SMCCMDS|SMCPARMS*]

Level: 0

Explanation: The SMC encountered a command that specified keyword *KKKKKKKK* without an accompanying value (required by most keywords).

System Action: Processing continues. The command is ignored.

User Response: Ensure that the syntax in the command data set is correct, or enter the corrected command.

SMC0018

Keyword *KKKKKKKK* of the *CCCCCCC* command is not allowed for *EEEEEEEE* [at line *nnnn* of *SMCCMDS|SMCPARMS*]

Level: 0

Explanation: The SMC encountered a command that specified keyword *KKKKKKKK*, which is not valid in the current operating environment *EEEEEEEE*.

System Action: Processing continues. The command is ignored.

User Response: Ensure that the specified keyword is valid in your environment.

SMC0019

Duplicate keyword *KKKKKKKK* specified for the *CCCCCCC* command [at line *nnnn* of *SMCCMDS|SMCPARMS*]

Level: 0

Explanation: The SMC encountered a command that specified the same keyword, *KKKKKKKK*, more than once.

System Action: Processing continues. The command is ignored.

User Response: Ensure that the syntax in the command data set is correct, or enter the corrected command.

SMC0020

Keyword *KKKKKKK1* of the *CCCCCCC* command is mutually exclusive with keyword *KKKKKKK2* [at line *nnnn* of *SMCCMDS|SMCPARMS*]

Level: 0

Explanation: The SMC encountered a command that specified multiple keywords, two of which (*KKKKKKK1* and *KKKKKKK2*), are mutually exclusive.

System Action: Processing continues. The command is ignored.

User Response: Ensure that the syntax in the command data set is correct, or enter the corrected command.

SMC0021

{COLD|WARM} start failure

Level: 0

Explanation: During initialization, the SMC subsystem detected an error.

System Action: The SMC subsystem terminates.

User Response: Look for SMC related messages in the SYSLOG or job log. Associated messages may be (but are not limited to) SMC0002, SMC0004, SMC0006, SMC0008, SMC0010, or SMC0011.

SMC0022

Invalid format or missing keywords for the CCCCCC command
[at line *nnnn* of SMCCMDS|SMCPARMS]

Level: 0

Explanation: The SMC encountered a command CCCCCC that contained either too many or too few keywords in the command line.

System Action: Processing continues. The command is ignored.

User Response: Ensure that the syntax in the command data set is correct, or enter the corrected command.

SMC0023

CCCCCC command successfully processed [at line *nnnn* of
SMCCMDS|SMCPARMS]

Level: 0

Explanation: The CCCCCC command was successfully validated and processed by the SMC.

System Action: None.

User Response: None.

SMC0024

SSSS subsystem initialization complete

Level: 0

Explanation: The SMC initialization process is complete. The SMC is ready to begin normal operations.

System Action: None.

User Response: None.

SMC0025

No {CCCCCCCC|control block} entries to list

Level: 0

Explanation: One of the following occurred:

- Command CCCCCCCC was specified with the LIST keyword. However, no entries were found in the SMC queue for the specified command.
- A LIST command was specified with a control block keyword. However, no control blocks of the specified type were found.

System Action: None.

User Response: None.

SMC0027

Keyword KKKKKKK1 of the CCCCCCCC command requires keyword KKKKKKK2 [at line nnnn of SMCCMDS|SMCPARMS]

Level: 0

Explanation: The SMC encountered a command that specified keyword KKKKKKK1, but not the required co-requisite keyword, KKKKKKK2.

System Action: Processing continues. The command is ignored.

User Response: Ensure that the syntax in the command data set is correct, or enter the corrected command.

SMC0028

STOP command received

Level: 0

Explanation: The MSP stop ('P') command was received by the SMC, and the SMC subsystem termination process is set to begin.

System Action: The SMC subsystem begins termination processing.

User Response: None.

SMC0029

CCCCCCCC command processing error; [matching entry not found|command line truncated; will be ignored|parameter truncated; command ignored] [at line nnnn of SMCCMDS|SMCPARMS]

Level: 0

Explanation: An error was found processing the CCCCCCCC command.

System Action: Processing continues. The command is ignored.

User Response: Use the LIST keyword to list the current SMC queue of entries; then ensure that the syntax in the command data set is correct, or enter the corrected command.

SMC0030

```
TRACE JOBNAME=JJJJJJJJ [STEPNAME=SSSSSSSS]  
[PROCSTEP=PPPPPPPP] [SNAPDUMP DDDDDDDD] CCCCCCCC
```

Level: 0

Explanation: The TRACE command was specified with the LIST keyword. The SMC0030 message lists the jobs, step, and PROC steps and the associated processes which have been specified for tracing.

System Action: None.

User Response: None.

SMC0031

No SMC start mode specified; defaulting to WARM start

Level: 4

Explanation: During SMC initialization, the subsystem detected that neither a WARM or COLD start was specified in the initialization program's execution parameters.

System Action: Initialization continues in WARM start mode.

User Response: None.

SMC0032

Number of SMC startup parameters specified exceeds maximum of
n

Level: 0

Explanation: During initialization, the SMC subsystem initialization program encountered an execution parameter string containing too many parameters.

System Action: The SMC subsystem terminates.

User Response: Correct the subsystem initialization startup procedure to specify the correct execution parameter string.

SMC0033

SMC startup parameter *PPPPPPPP* may not have a value

Level: 0

Explanation: During initialization, the SMC subsystem initialization program encountered a valid execution parameter, but it was specified as a keyword=value pair, where no value is allowed.

System Action: The SMC subsystem terminates.

User Response: Correct the subsystem initialization startup procedure to specify the correct execution parameter string.

SMC0034

SMC startup parameter *PPPPPPPP* must have a value

Level: 0

Explanation: During initialization, the SMC subsystem initialization program encountered a valid execution parameter, but it was not specified as a keyword=value pair, and a value is required.

System Action: The SMC subsystem terminates.

User Response: Correct the subsystem initialization startup procedure to specify the correct execution parameter string.

SMC0035

Error processing SMC startup parameter *PPPPPPPP*; *CCCCCCCCCCCC*

Level: 0

Explanation: During initialization, the SMC subsystem initialization program encountered an error in the execution parameter string. The string *CCCCCCCCCCCC* indicates the type of error encountered.

System Action: The SMC subsystem terminates.

User Response: Correct the subsystem initialization startup procedure to specify the correct execution parameter string.

SMC0036

SMC startup parameter *PPPPPPPP* successfully processed

Level: 4

Explanation: During SMC initialization, the execution parameter *PPPPPPPP* was successfully verified and processed.

System Action: None.

User Response: None.

SMC0037

Invalid SMC startup parameters; subsystem terminating

Level: 0

Explanation: During initialization, the SMC subsystem initialization program detected an error processing the execution parameter string.

System Action: The SMC subsystem terminates.

User Response: Look for SMC related messages in the SYSLOG or job log. Associated messages may be (but are not limited to) SMC0032 SMC0033, SMC0034, or SMC0035.

SMC0038

Another SMC system *SSSS* is already active

Level: 0

Explanation: During initialization, the SMC subsystem initialization program detected a different SMC subsystem, *SSSS*, already active on the system.

System Action: The initializing SMC subsystem terminates.

User Response: Only one SMC can be active on a system at a time.

- If SMC *SSSS* is active, and is preventing the current SMC from initializing, terminate SMC *SSSS*.
- If SMC *SSSS* was terminated abnormally and is not truly active, restart the current SMC subsystem with the RESET execution parameter.

SMC0039

Identically named subsystem *SSSS* is already active

Level: 0

Explanation: During initialization, the SMC subsystem initialization program detected an identically named subsystem *SSSS* already active on the system.

System Action: The initializing SMC subsystem terminates.

User Response: Determine whether the subsystem SMC *SSSS* is active. If so, terminate SMC *SSSS*. If SMC *SSSS* was terminated abnormally and is not truly active, restart the current SMC subsystem with the RESET execution parameter.

SMC0040

SMC subsystem *SSSS* is already active; RESET specified; startup continuing

Level: 4

Explanation: During initialization of SMC subsystem *SSSS*, the initialization program detected that the prior SMC subsystem terminated abnormally, but the user specified the RESET execution parameter to ignore this condition.

System Action: None.

User Response: None.

SMC0041

{Command|Comment} beginning at line *nnnn* of {SMCCMDS|SMCPARMS} is unterminated

Level: 4

Explanation: A command or comment beginning at line *nnnn* of an input command file ended with a continuation character (+), but no continuation was found.

System Action: Processing continues. The command containing the unterminated string is ignored.

User Response: Ensure that the syntax in the command data set is correct.

SMC0042

Job *JJJJJJJJ* step *SSSSSSSS* not allocatable before SMC modification

Level: 4

Explanation: During execution of job *JJJJJJJJ* step *SSSSSSSS*, the SMC allocation component detected that the job step was not allocatable before any allocation influencing was performed.

System Action: None. The job is failed by MSP or express-canceled by JES.

User Response: Correct the JCL.

SMC0043

Job *JJJJJJJJ* step *SSSSSSSS* not allocatable at MINLVL=*nn*; failing DD *DDDDDDDD*

Level: 4

Explanation: During execution of a job with tape allocation, the SMC allocation component detected that the job is not allocatable at the specified minimum exclusion level (MINLVL).

System Action: The job is failed by MSP or express-canceled by JES.

User Response: Correct the JCL, or change the MINLVL for the specified job.

SMC0044

SMC subsystem termination in progress; no allocation influence for job *JJJJJJJJ* step *SSSSSSSS*

Level: 8

Explanation: During execution of job *JJJJJJJJ* step *SSSSSSSS*, the SMC allocation component detected that the SMC subsystem was being terminated.

System Action: No allocation influencing is performed for the job.

User Response: None.

SMC0045

Conflicting exclusion criteria for job *JJJJJJJJ* step *SSSSSSSS*
DD *DDDDDDDD*

Level: 8

Explanation: Messages SMC0045 and SMC0046 are always produced together. See the explanation for message SMC0046 for more information.

System Action: None.

User Response: None.

SMC0046

CCCCCCCCCCCCCCCC would have excluded all devices; not honored

Level: 8

Explanation: When the SMC allocation component attempted to apply the exclusion criteria CCCCCCCCCCCCCC for job JJJJJJJJ step SSSSSSSS DD DDDDDDDD, no devices remained in the current exclusion level EDL. The SMC0045 and SMC0046 messages are always produced together.

For information about exclusion criteria, refer to the keyword column of the "Drive Exclusion Levels" tables in Chapter 5 of the *SMC Configuration and Administration Guide*.

System Action: None. The criteria that would have eliminated all devices is ignored.

User Response: Examine the message to determine which exclusion criteria could not be honored. If possible, change the specification of the allocation policy to eliminate policies that conflict, for example, specifying a subpool name or esoteric name incompatible with media or recording technique.

SMC0047

Esoteric EEEEEEEE contains no known devices; ignored for job JJJJJJJJ step SSSSSSSS DD DDDDDDDD

Level: 8

Explanation: During execution of job JJJJJJJJ step SSSSSSSS, the SMC allocation component encountered a user policy esoteric, EEEEEEEE (from POLICY, TAPEREQ or user exit), that did not contain any tape devices in the current EDL.

System Action: The specified esoteric is ignored.

User Response: None.

SMC0048

Support ending for CCCCCCCC1, change to CCCCCCCC2

Level: 0

Explanation: A CCCCCCCC1 command or keyword was entered. However, the command or keyword will not be supported in the next release, where the CCCCCCCC2 command or keyword will provide equivalent functionality.

System Action: None.

User Response: Change the CCCCCCCC1 command or keyword to CCCCCCCC2.

SMC0049

No eligible TAPEPLEX for job *JJJJJJJJ*

Level: 8

Explanation: During execution of job *JJJJJJJJ*, the SMC allocation component did not find any TapePlexes at the correct release level, or no valid TAPEPLEX commands were processed.

System Action: If ALLOCDEF FAILnoinfo is specified, the SMC marks all devices ineligible. Otherwise, no allocation influencing is performed for the job.

User Response:

- If TapePlexes are implied using the MSP SSCVT chain or via the TAPEPLEX command LOCSUBsys parameter, ensure that the HSC on the host is active and at the correct level.
- If TapePlexes on another host are defined using the TAPEPLEX command, ensure that the HSC on the remote host defined by the SERVER command is active and at the correct level. Also ensure that the HTTP server is active on the remote host.

SMC0051

SMC subsystem interface error for job *JJJJJJJJ*; reason=
SSSSSSSS function=*CCCCCCCC*

Level: 4

Explanation: SMC processing in an MSP initiator address space attempted to communicate with the SMC subsystem in order to process an allocation or mount request but encountered an error. The reason for the failure is *SSSSSSSS* while the function attempted was *CCCCCCCC*.

System Action: The SMC terminates its processing of the allocation or mount request.

User Response: Investigate the cause of the error by looking for related SMC subsystem or MSP error messages.

SMC0052

User exit *nn* {inactive|abended and disabled}

Level: 8

Explanation: During execution of a job, the SMC allocation or message handling component invoked the user exit *nn*. However, the user exit is currently inactive or has abended and is now disabled.

System Action: Processing continues without the user exit.

User Response: Correct the user exit.

SMC0053

**** SMC U1099 ABEND AT CCCCCCn ****

Level: 0

Explanation: An SMC task has abended in module CCCCCC at abend sequence number *n*.

System Action: If the abend occurs in the address space of a tape allocation job, the SMC subsystem does not influence the job's allocation. If the abend occurs in the SMC started task address space, a restart of the SMC subsystem may be required.

User Response: Look for SMC or Fujitsu related messages in the SYSLOG or job log. Save the associated logs, dump data set, and JCL, and contact StorageTek Software Support.

SMC0054

MSGJOB LVL=*nn* for {DEFAULT SETTING|JOBNAME=JJJJJJJJ}
[STEPNAME=SSSSSSSS] [PROCSTEP=PPPPPPPP]

Level: 0

Explanation: A MSGJOB command was specified with the LIST keyword. Each unique job, job step, and PROC step entry found in the MSGJOB queue is displayed in a separate SMC0054 message, followed by the SMC defaults in a final SMC0054 message. *nn* indicates the message level, and any messages at that indicated level or lower are produced on that job's job log in JES.

System Action: None.

User Response: None.

SMC0055

ALLOCJOB {BYPASSed|MINLVL=*nn*}[SEPLVL=MIN|MAX|*nn*] for {JOBNAME=JJJJJJJJ}[STEPNAME=SSSSSSSS][PROCSTEP=PPPPPPPP][SNAPDUMP DDDDDD] PPPPPPPP

Level: 0

Explanation: An ALLOCJOB command was issued with the LIST keyword. Each unique job, job step, and PROC step entry found in the ALLOCJOB queue is displayed in a separate SMC0055 message. The BYPASSED message indicates that the specified job, job step, or PROC step will not have any of its tape allocations influenced by the SMC. MINLVL=*nn* indicates the desired minimum exclusion level at which affinity and GDG chains are separated.

System Action: None.

User Response: None.

SMC0056

nn Bytes:

```

AAAAAAAA +0000 | XX.XX XX.XX XX.XX XX.XX | CC..CC |
AAAAAAAA +0010 | XX.XX XX.XX XX.XX XX.XX | CC..CC |
AAAAAAAA +0000 | XX.XX XX.XX XX.XX XX.XX | CC..CC |

```

Level: 0

Explanation: An SMC Llist command was issued. The SMC0056 multiline message lists the *nn* bytes of storage in translated hexadecimal (*xx.xx*) and character (*cc.cc*) format, each line listing the next 16 bytes (X'10') bytes of storage, beginning at hexadecimal address *aaaaaaaa*.

System Action: None.

User Response: None.

SMC0057

No {SMCPARMS|SMCCMDS} DDNAME statement found

Level: 8

Explanation: During SMC initialization, the specified SMCPARMS DD or SMCCMDS DD was not present in the SMC startup procedure.

System Action: Initialization continues.

User Response: None.

SMC0058

Error opening {DDNAME {SMCPARMS|SMCCMDS}|DSNAME DDDDDDD}

Level: 0

Explanation: The SMC encountered a READ command, but the specified DDNAME or DSNAME could not be opened.

System Action: The READ command is ignored.

User Response: Look for Fujitsu related messages in the SYSLOG or job log, and refer to Fujitsu documentation for more information.

SMC0059

Identically named subsystem SSSS is initializing

Level: 0

Explanation: During initialization, the SMC subsystem initialization program detected an identically named SMC subsystem, SSSS, already being initialized (but not yet fully active).

System Action: The currently initializing SMC subsystem terminates.

User Response: Only one SMC can be active on a system at a time. If the prior SMC subsystem, SSSS, was terminated abnormally, and is not truly active, then restart SMC SSSS with the RESET execution parameter.

SMC0060

I/O error reading {DDNAME {SMCPARMS|SMCCMDS}|DSNAME DDDDDDD}

Level: 0

Explanation: The SMC received an I/O error attempting to read the SMCPARMS or SMCCMDS data set specified in the SMC started procedure or a data set specified on a READ command.

System Action: The indicated data set is not processed.

User Response: Determine the cause of the error. If the input data set is a PDS, ensure that a member name was specified.

SMC0061

Command beginning at line *nnnn* of {SMCCMDS|SMCPARMS} is too long; input ignored

Level: 4

Explanation: The SMC encountered a multi-line command beginning at line *nnnn* of the specified file. This command exceeds 1024 characters in length.

System Action: Processing continues. The entire multi-line is ignored.

User Response: Ensure that the command data set has the correct syntax.

SMC0062

Command *CCCCCCC* [with parameter *PPPPPPP*] is not allowed
[*{from console|at line nnnn of SMCCMDS|SMCPARMS}*]

Level: 0

Explanation: The SMC encountered a command or a command parameter that is not supported for the indicated command origin. For example, the READ command is not supported if encountered during processing of another READ command.

System Action: The command is ignored.

User Response: Issue the command from a valid command origin.

SMC0063

MSGDEF settings:
CCCC....CCCC

Level: 0

Explanation: A MSGDEF command has been issued with the LIST keyword. The SMC0063 multiline message lists the current settings for the SMC subsystem. Refer to the MSGDEF command for parameter descriptions.

System Action: None.

User Response: None.

SMC0066

ALLOCDEF settings:
CCCC....CCCC

Level: 0

Explanation: An ALLOCDEF command has been issued with the LIST keyword. The SMC0066 multiline message lists the current settings for the SMC subsystem. Refer to the ALLOCDEF command for parameter descriptions.

System Action: None.

User Response: None.

SMC0069

SMCERSLV release level *LLLLLL1* does not match SMC release level *LLLLLL2*

Level: 0

Explanation: Module SMCERSLV is at release level *LLLLLL1* which does not match SMC release level *LLLLLL2*.

System Action: The SMC does not initialize.

User Response: Reassemble SMCERSLV at the correct release level and restart the SMC.

SMC0070

SMC maintenance has been applied; reassemble SMCERSLV

Level: 0

Explanation: SMC maintenance was applied and affected the module SMCERSLV, but SMCERSLV was not reassembled.

System Action: The SMC does not initialize.

User Response: Reassemble SMCERSLV using the correct level of SMC macros and restart the SMC.

SMC0074

Unsupported virtual label type for job *JJJJJJJJ* step *SSSSSSSS*
DD *DDDDDDDD*

Level: 8

Explanation: All virtual devices were previously excluded for the DD because of an unsupported label type (NL). A subsequent exclusion criteria requesting virtual drives could not be honored. Message SMC0046 describes the criteria not honored.

System Action: The DD is allocated to a nonvirtual drive. Nonlibrary drives are preferred over library drives.

User Response: Change the JCL to request a supported label type, or change the policy to direct the allocation to a different device type.

SMC0075

SEPLVL cannot be less than MINLVL on the CCCCCC command [at line *nnnn* of SMCCMDS|SMCPARMS]

Level: 0

Explanation: The SMC encountered a command that specified either a SEPLVL that is lower than the applicable MINLVL or a MINLVL higher than the applicable SEPLVL.

System Action: Processing continues. The command is ignored.

User Response: Ensure that command MINLVL and SEPLVL values are correct in the command data set, or enter the corrected command.

SMC0077

Subtask CCCCCC terminating at retry count *n*; please stop and restart SMC subsystem

Level: 0

Explanation: The specified SMC subsystem task abnormally terminated *N* times, and could not be restarted. The subsystem is now operating without a required service.

System Action: Processing continues. However, specific allocation or command facilities may be affected.

User Response: Stop and restart the SMC subsystem. If the named subtask is SMCOCMD, use the MSP CANCEL command to terminate the subsystem.

SMC0078

No command prefix defined

Level: 0

Explanation: No CMDDEF command specified a command prefix in the SMCPARMS data set.

System Action: Processing continues.

User Response: If a command prefix is desired, add the CMDDEF command to the SMCPARMS data set. The command is processed the next time SMC is initialized.

SMC0079

The command prefix is PPPPPPP

Level: 0

Explanation: The command prefix for the subsystem is set to PPPPPPP.

System Action: The SMC now accepts commands prefixed with PPPPPPP.

User Response: None.

SMC0080

Command prefix value VVVVVVVV contains invalid character C at line nnnn of SMCPARMS

Level: 0

Explanation: The command prefix value VVVVVVVV of the CMDDEF command contained an invalid character C.

System Action: Processing continues. The command is ignored.

User Response: Review the list of valid characters for the command prefix listed with the CMDDEF command description. Update the CMDDEF command in the SMCPARMS data set with the new prefix value. The command is processed the next time the SMC is initialized.

SMC0081

Command prefix not added; [prefix is not unique|CPF system error]

Level: 0

Explanation: The command prefix was disallowed by the CPF facility because the prefix was not unique or a system error occurred.

System Action: Processing continues. The command is ignored.

User Response:

- If the prefix is not unique, issue the MSP DISPLAY OPDATA command and compare the prefix with those of the other subsystems. The command prefix **cannot** include a command string, a command abbreviation, or any string that invokes a command. The command prefix **cannot** include a string that is a subset or superset of an existing prefix beginning with the same character.
- If a CPF error occurred, look for Fujitsu related messages in the SYSLOG and refer to Fujitsu documentation for the explanation.

SMC0082

Command prefix already set

Level: 0

Explanation: The command prefix can be specified only once while the SMC is initializing and cannot be changed during execution.

System Action: Processing continues. The command is ignored.

User Response: To change the command prefix, update the CMDDEF statement in the SMCPARMS data set and recycle the SMC.

SMC0084

MMM DD YYYY HH:MM:SS SSSS active on hostid HHHH

Level: 4

Explanation: The date (MMM DD YYYY), time (HH:MM:SS), subsystem name (SSSS) and MSP hostid (HHHH) are displayed once a day at midnight and during SMC initialization.

System Action: None.

User Response: None.

SMC0085

SMCBPREI: IEFSSI failed RC=XX RS=XXXX

Level: 0

Explanation: The SMC subsystem pre-initialization routine (SMCBPREI) encountered an error.

System Action:

- If the Return Code (RC) is 4 or less, the SMC subsystem was defined.
- If the Return Code (RC) is 8 or higher, the SMC subsystem was not defined.

User Response: Investigate the Return Code (RC) and Reason (RS) and take the necessary action. The return code and reason are documented in the Fujitsu manual *Task Management Macro Instructions Reference Manual*.

SMC0086

SMC SUBSYSTEM TASKS:

A (PCE)	A (TCB)	USE	CT-S	PROGRAM	JOBNAME	JOBID	LAST
XXXXXXXX	XXXXXXXX	00001	BB-W	SMCBINT	JJJJJJJJ	Jnnnn	TTTTTT
XXXXXXXX	XXXXXXXX	00001	BM-W	SMCBMID	JJJJJJJJ	Jnnnn	TTTTTT
XXXXXXXX	XXXXXXXX	00001	QM-W	SMCQMGR	JJJJJJJJ	Jnnnn	TTTTTT
XXXXXXXX	XXXXXXXX	00001	J				
XXXXXXXX	XXXXXXXX	00001	O -W	SMCOCMD	JJJJJJJJ	Jnnnn	TTTTTT
XXXXXXXX	XXXXXXXX	00001	BL-W	SMCBLOG	JJJJJJJJ	Jnnnn	TTTTTT
XXXXXXXX	XXXXXXXX	00001	QW-X	SMCQWRK	JJJJJJJJ	Jnnnn	TTTTTT
. . . .							
XXXXXXXX	XXXXXXXX	nnnnn	QW-X	SMCQWRK	JJJJJJJJ	Jnnnn	TTTTTT

SMCQWRK executing tasks=nn waiting tasks=nn requests=nn

Level: 0

Explanation: An SMC LIST TASK command was issued. The SMC0086 multiline message lists status of each SMC subsystem task. The last line lists the number of SMCQWRK tasks currently executing, waiting for work, as well as the total number of requests processed.

System Action: None.

User Response: None.

SMC0087

EXTVOLESOT esoteric EEEEEEEE not found [at line nnnn of SMCCMDS | SMCPARMS]

Level: 0

Explanation: An ALLOCDEF command was issued with the EXTVOLESOT keyword specifying EEEEEEEE. However, the specified *esoteric-name* is not a valid MSP esoteric.

System Action: The specified ALLOCDEF command is not processed.

User Response: Reissue the ALLOCDEF command specifying a valid MSP esoteric name.

SMC0088

Unable to [acquire/release] resource CCCCCCCC; attempt by
JJJJJJJJ XXXXXXXX1 owned by XXXXXXXX2

Level: 0

Explanation: A shared SMC resource could not be acquired or freed successfully. Job JJJJJJJJ is the task currently attempting to acquire or free the resource, but cannot because another task holds the resource.

System Action: Jobname JJJJJJJJ may not be processed correctly.

User Response: Contact StorageTek Software Support.

SMC0089

Unable to start subtask CCCCCCCC

Level: 0

Explanation: During initialization, the indicated SMC subsystem task could not be successfully attached.

System Action: The SMC subsystem terminates.

User Response: Look for related MSP or SMC messages in the SYSLOG or SMC job log.

SMC0090

Unable to restart subtask CCCCCCCC

Level: 0

Explanation: During subsystem processing the indicated SMC subsystem task abended and could not be restarted.

System Action: Processing continues. However, subsystem processing or command facilities may be affected.

User Response: Stop and restart the SMC subsystem. If the indicated subtask is SMCOCMD, use the MSP CANCEL command to terminate the subsystem.

SMC0091

Could not allocate job JJJJJJJJJ step SSSSSSSS after applying
all exclusion levels; backing up until allocatable

Level: 8

Explanation: The indicated job step would not allocate when all exclusion criteria were applied to all DDs in the step. This means that the remaining set of drives is insufficient for each DD to be assigned a unique drive.

System Action: The SMC backs out exclusion criteria on selected DDs in the step until the set of remaining drives is sufficient to allocate to all DDs in the step.

User Response: None.

SMC0092

IDAX Settings:
CCCC...CCCC

Level: 0

Explanation: An IDAX command has been issued with the LIST keyword. The SMC0092 multiline message lists the current setting for the SMC subsystem. Refer to the IDAX command for a description of keywords and their meanings.

System Action: None.

User Response: None.

SMC0093

TCPIP TCPNAME=CCCCCCCC ADSNAME=CCCCCCCC

Level: 0

Explanation: A TCPIP LIST command was issued. The current values of the TCPNAME and ADSNAME are displayed. If the SMC is using the default settings, "default" is displayed.

System Action: None.

User Response: None.

SMC0094

MOUNTDEF settings:
CCCC...CCCC

Level: 0

Explanation: A MOUNTDEF command has been issued with the LIST keyword. The SMC0094 multiline message lists the current settings for the SMC subsystem. Refer to the MOUNTDEF command for a description of keywords and their meanings.

System Action: None.

User Response: None.

SMC0095

UX01 function code UX01RPLY not supported

Level: 4

Explanation: The function code return of UX01RPLY (reply to a WTOR message) is not supported by SMC.

System Action: None. The user exit is ignored.

User Response: None.

SMC0096

Invalid UX01 function code X'XX'

Level: 4

Explanation: A user exit 01 returned an invalid function code of X'XX'.

System Action: All data returned by this invocation of UX01 is ignored.

User Response: Correct the UX01 to return only function codes documented in the *NCS User Exit Guide*.

SMC0097

UX01 function code X'XX' not valid for message *MMMMMMMM*

Level: 4

Explanation: The SMC detected that the action code returned for a message (mount, dismount, or swap) did not match the action for an SMC default message.

System Action: All data returned by this invocation of UX01 is ignored.

User Response: Correct the UX01 to return a function code compatible with the message.

SMC0098

UX01 drive *XXXX1* does not match message drive *XXXX2*, using UX01 drive

Level: 4

Explanation: The device address returned from UX01 does not match the address specified in the message.

System Action: The device address returned from UX01 is used in the message processing.

User Response: Ensure that UX01 is functioning as desired.

SMC0099

Drive *XXXX* not a TAPEPLEX drive

Level: 4

Explanation: A user exit 01 returned a drive *XXXX*, which is not a library or virtual drive.

System Action: All data returned by this invocation of UX01 is ignored.

User Response: Ensure that UX01 is functioning as desired.

SMC0100

Invalid UX01 drive *XXXX*

Level: 4

Explanation: A user exit 01 returned an invalid drive address of *XXXX* which is not defined as a valid tape device on this system.

System Action: All data returned by this invocation of UX01 is ignored.

User Response: Correct the UX01.

SMC0101

Invalid UX01 or TAPEREQ subpool *SSSSSSSSSSSS* from TAPEPLEX *PPPPPPPP* for job *JJJJJJJJ*

Level: 4

Explanation: A POLicy, TAPEREQ, or user exit 01 specified a subpool name that was not recognized by TAPEplex *PPPPPPPP*, which owned the device for the mount request.

System Action: The default subpool 0 is used.

User Response: Correct the POLicy, TAPEREQ, or UX01 to specify a valid subpool.

SMC0102

Invalid UX01 volser VVVVVV

Level: 4

Explanation: A user exit 01 returned a volume serial containing invalid characters.

System Action: The volume serial returned by this invocation of UX01 is ignored.

User Response: Correct the UX01 to return a valid volume serial.

SMC0103

Unrecoverable mount error on device XXXX volser VVVVVV for JOB
JJJJJJJJ

Level: 0

Explanation: The SMC detected a volume mount error in response to an IAT5310 message for a mount requested in message IAT5210.

System Action: The SMC breaks the mount loop and issues a dismount to the indicated device XXXX. The job remains in the MDS VERIFY queue.

User Response: Refer to the IAT5310 message for the cause of the mount error and take corrective action.

SMC0104

Default recording technique set for
TAPEPLEX=CCCCCCC device XXXX

Level: 4

Explanation: The configuration query response from TapePlex CCCCCCC returned device address XXXX as a TapePlex-owned device, but could not determine the model type for the device.

System Action: The SMC sets the default recording technique for the device based on the UCB device type. Processing continues.

User Response: Verify that any maintenance for new device types has been applied to all NCS products, including SMC, or issue an SMC UNITAttr command for the device specifying the correct model information.

SMC0105

Keyword KKKKKKKK of the CCCCCCC command is required

Level: 0

Explanation: The command CCCCCCC was issued without the required keyword KKKKKKKK.

System Action: The command is not processed.

User Response: Re-issue the command with the required keyword.

SMC0106

Mount of volser VVVVVV in TAPEPLEX PPPPPPPP on device XXXX not in library

Level: 0

Explanation: An SMC MOUNTDEF VOLWATCH option is ON. The SMC has detected that a volume resident in TapePlex PPPPPPPP is being requested to be mounted on a nonlibrary drive.

System Action: None.

User Response: Cancel the job requesting the mount, or eject the volume to satisfy the mount request.

SMC0107

Swap VVVVVV from XXXX1 to XXXX2

Level: 4

Explanation: The SMC has intercepted DDR swap processing. XXXX2 is either the original device selected to swap to or a device selected by SMC that more closely matches the device characteristics of XXXX1.

System Action: DDR swap processing continues.

User Response: None.

SMC0108

No compatible drive found for SWAP processing

Level: 0

Explanation: The SMC has intercepted DDR swap processing. The original device chosen to swap to is not compatible with the swap from device and the SMC could not locate a compatible alternate device.

System Action: DDR swap processing continues.

User Response: If no compatible device is available, reply NO to message KHE201D or KHE206D to stop the swap process. If a compatible device is offline, vary it online and reply with its device number to message KHE201D or KHE206D.

SMC0109

The SMC subsystem is running in key *n*; results are unpredictable; reply 'Y' to continue or 'N' to terminate

Level: 0

Explanation: During initialization SMC detected that it is running in key *n*, not 1 through 7.

System Action: The SMC waits until a reply is received.

User Response: A reply of N stops SMC. A reply of Y causes SMC to continue initialization, though results are unpredictable. Possible problems are S0C1 and S0C4 ABENDs. To prevent this message, update the Program Properties Table (PPT) with "PPT PGMNAME(SMCBINT),SYST,KEY(*n*)", where *n* is between 1 and 7, inclusive.

SMC0110

Allow swap of VVVVVV from XXXX1 to XXXX2; Reply 'Y', 'N' or DEVICE

Level: 0

Explanation: The SMC has intercepted DDR swap processing. The SMC is awaiting operator approval to allow the swap.

System Action: The SMC continues processing; however, the swap cannot complete until an operator reply is entered.

User Response: To allow the swap to proceed using the selected device XXXX2, reply Y. To select a different swap to device, reply with its device address. The SMC does not validate a new device address. To cancel the swap, reply N. If an I/O error on device XXXX1 caused the swap, a reply of N causes the job to fail.

SMC0111

USER defined message ID: MMMMMMMM

Level: 0

Explanation: The SMC has listed the messages that were added using the USERMsg command.

System Action: Both SMC default and USERMsg added messages are sent to user exit 01 for each library subsystem. SMC processes USERMsg added messages according to the response from user exit 01.

User Response: None.

SMC0112

Cannot add duplicate message ID MMMMMMMM at line nnnn of SMCPARMS

Level: 0

Explanation: The USERMsg command was issued to add a new message ID that SMC will intercept. The supplied message ID MMMMMMMM is a duplicate of a message already defined to SMC.

System Action: The message is not added.

User Response: None.

SMC0113

```
SERVER=SSSSSSSS CCCCCCCC
Status={active|never active|inactive|disabled}
Messages=nnnn
Retries=nnnn
Init errors=nnnn
Errors=nnnn
```

Level: 0

Explanation: A SERVer command has been issued with the LIST keyword. The SMC0113 multiline message lists the server settings and status for each server defined to the SMC subsystem. Refer to the SERVer command for parameter descriptions.

- **STATUS** indicates the status of the server.
- **active** indicates that this server is the current path through which the specified TapePlex will be accessed.
- **never active** indicates that communication was never attempted on this path, or was attempted but never succeeded.
- **inactive** indicates that another server path is active, or that the last communication attempt on this path failed.
- **disabled** indicates that the server has been disabled by a discovered incompatibility, by reaching the FAIL limit, or by an operator command.
- **Messages** indicates the number of logical messages (volume lookup requests, mounts, dismounts) on this server path.
- **Retries** indicates how many message retries have been attempted.
- **Init errors** indicates the current count of number of errors for an inactive server.
- **Errors** indicates the total number of errors on this server.

System Action: None.

User Response: None.

SMC0116

```
Cannot find TAPEPLEX|STORMNGR PPPPPPPP for SERVER SSSSSSSS [at
line nnnn of SMCCMDS|SMCPARMS]
```

Level: 0

Explanation: A SERVer command was issued with a TapePlex or STORMNGR name that was not previously defined.

System Action: The server is not added or updated.

User Response: Specify a TAPEPlex command to define the TapePlex or a STORMNGR command to define the STORMNGR, then specify the SERVer command.

SMC0117

Cannot change TAPEPLEX|STORMNGR name for existing SERVER
SSSSSSSS [at line nnnn of SMCCMDS|SMCPARMS]

Level: 0

Explanation: A SERVER command was issued with the NAME of an existing server and a TapePlex or STORMNGR name, but its TapePlex or STORMNGR name did not match the name set when the server was originally defined.

System Action: The command is rejected.

User Response: Omit the Tapeplex or STORMNGR name, change the Tapeplex or STORMNGR name to match the existing server, or change the server name to add a new server.

SMC0118

No LOCSUBSYS for [LOCENABLE|LOCDISABLE] parameter on TAPEPLEX
command [at line nnnn of SMCCMDS|SMCPARMS]

Level: 0

Explanation: A TAPEPLEX command was issued with a LOCENABLE or LOCDISABLE parameter, but the TapePlex was not defined with a LOCSUBSYS subsystem name.

System Action: This message is a warning. The TapePlex will be added or modified, but the LOCENABLE or LOCDISABLE parameter is ignored.

User Response: None.

SMC0119

[SERVER|LOCSUBSYS] CCCCCCCC now disabled

Level: 0

Explanation: The SMC detected TCP/IP errors in excess of the FAIL count or detected a fatal error for a local subsystem. See the preceding SMC0128/SMC0129 messages for the reason for the disable.

System Action: None. If there are no additional server paths defined for the associated library, the library hardware is no longer accessible from this host.

User Response: Correct the problem with the TCP/IP network, SMC server, host operating system, or the HSC subsystem, and re-ENABLE the SERVER or LOCSUBsys.

SMC0120

NAME must be specified to add or modify a SERVER [at line nnnn
of SMCCMDS|SMCPARMS]

Level: 0

Explanation: The user entered a SERVER command to add a new server or modify an existing server path, but the server path name was not specified.

System Action: None.

User Response: Enter the SERVER command specifying the server path name.

SMC0121

UEXIT *nn* is now [ENABLED/DISABLED]

Level: 0

Explanation: The user entered a UEXIT *nn* ENABLE or DISABLE command, or the SMC detected an abend in the specified user exit. The specified user exit is now ENABLED or DISABLED.

System Action: None.

User Response: If the SMC automatically disabled the user exit due to an abend, the exit cannot be re-enabled unless it is also reloaded.

SMC0122

```
UEXIT=nn
Status={active|disabled|abended}
CCCC...CCCC
Sequence=nn
Loaded=YYYY-MM-DD HH:MM:SS
Changed=YYYY-MM-DD HH:MM:SS
```

Level: 0

Explanation: A UEXIT command was issued with the LIST keyword. The SMC0122 multiline message lists the user exit status for each user exit defined to the SMC subsystem. REfer to the UEXIT command for parameter descriptions.

- **nn** indicates the SMC user exit number (type).
- **STATUS** indicates the user exit status.
- **active** indicates that the exit is loaded and active.
- **disabled** indicates that the exit is loaded but was de-activated by the UEXIT disable keyword.
- **abended** indicates the user exit abended. A new version must be loaded for this exit to be re-activated.
- **Sequence** indicates how many loads have been performed for this user exit.
- **Loaded** indicates when this version of the module was loaded.
- **Changed** indicates when this version of the module was activated or disabled.

System Action: None.

User Response: None.

SMC0123

```
Drive range mismatch between CLIENT(XXXX1-XXXX2) and SERVER
(XXXX3-XXXX4)
```

Level: 0

Explanation: A DRIVemap command was issued. One of the specified CLient range did not match the format of the corresponding SERver range.

System Action: None.

User Response: Reissue the command, ensuring that the CLient parameter and the SERver parameter have corresponding formats and number of drives.

SMC0124

ABENDED or INACTIVE UEXIT *nn* must be reloaded to ENABLE [at line *nnnn* of SMCCMDS|SMCPARMS]

Level: 0

Explanation: A UEXIT *nn* ENABLE command was issued for a user exit that had previously abended, or inactivated itself via a return code.

System Action: None.

User Response: Use the UEXit command with the LOAD keyword to reload the exit.

SMC0125

UEXIT *nn* already [ENABLED/DISABLED][at line *nnnn* of SMCCMDS|SMCPARMS]

Level: 0

Explanation: A UEXIT *nn* ENABLE or DISABLE command was issued but the exit was already in the specified state.

System Action: None.

User Response: Verify the exit number you are trying to alter.

SMC0126

UEXIT *nn* not valid for JES [at line *nnnn* of SMCCMDS|SMCPARMS]

Level: 0

Explanation: A UEXIT command was issued for a user exit number not valid for this configuration.

System Action: None.

User Response: Verify the user exit number for your configuration.

SMC0127

Cannot resolve HOST name *H...H* [at line *nnnn* of SMCCMDS|SMCPARMS]

Level: 0

Explanation: A SERVer command was issued using the HOST keyword specification. However, the SMC could not resolve the IP address using the specified HOST *name*.

System Action: The SERVer command is ignored.

User Response: Enter the correct HOST name or use the IPADDRESS keyword instead.

SMC0128

```
TapePlex error:
{Fatal comm error detected|
  Initialization error number nn or {nn|unlimited}|
  Comm error number nn of {nn|unlimited}
  Comm error limit exceeded}
JOB=JJJJJJJJ IIIIIIII TASK=XXXXXXXXXXXXXXXXX {MSG=XXXXXXXX}
TAPEPLEX|STORMNGR=TTTTTTTT {SUBSYSTEM=AAAA|SERVER=SSSSSSSS}
REQUEST=FFFF
{Client {IP=NNN.NNN.NNN.NNN} socket=NN port={nnnn|ANY}}
{Server IP=NNNN.NNNN.NNNN.NNNN port=nnnn}
{Bytes out=nnnn in=nnnn}
{Error=EEEE...EEEE}
{Reason=RRRR...RRRR}
{Response from STK HTTP server follows: HHHH...HHHH}
SMC comm RC=nnnn
```

Explanation: The SMC encountered an interface or communication error attempting to communicate with a TapePlex or STORMNGR. The SMC0128 multiline message first lists the jobname, transaction type, and TapePlex or STORMNGR name associated with the error.

If the communication error was produced for a local TapePlex or STORMNGR using cross memory services on this same host (i.e., not using a server) then the next line will list the interface error.

If the communication error was produced for a remote HTTP server or its associated remote HSC TapePlex or STORMNGR using TCP/IP, then one of the message reason lines will be displayed.

Examples of the reason strings include:

- Specific TCP/IP function errors (connect, send, recv, etc.)
- Data error (incomplete or invalid data response)
- Subsystem inactive, not found, or at an incompatible release level
- Subsystem function error
- HTTP server not authorized
- HSC ASCOMM error
- Interface or communication timeout

Note – Certain remote errors may result in a display of the entire HTTP server response as follows:

```
Response from HTTP server follows:
HTTP 1.0 401 Unauthorized
```

If the message indicates “Comm error limit (*nnn*) exceeded” then the SMC0128 message will be followed by an SMC0119 message and the server path will be disabled by the SMC.

If the message indicates an “Initialization error” then the error occurred before any successful communication to the named server path. Such errors are not counted against the cumulative error count on the server path, and will not result in the named server being automatically disabled by the SMC.

Also, "Initialization error" messages will not be generated for every request, but will only be generated at 5 minute intervals until the path is successfully activated.

System Action: The allocation or mount event may not be processed by the SMC.

User Response: Use the specified error reason to determine the cause of the problem. If the error was produced for a remote server, verify that the HTTP server is active.

SMC0129

{ERROR|WARNING}: No cartridge transport(s) for XXXX1- [XXXX2]
for {UNITATTR|DRIVEMAP} {ADDRESS|CLIENT}

Level: 0

Explanation: A UNITATTR or DRIVEMAP command was issued specifying a device XXXX1 or range XXXX1-XXXX2. None of the specified devices is an MSP-defined cartridge transport device.

System Action:

- If the message indicates an ERROR, the command is not processed.
- If the message indicates a WARNING, the SMC stores the value and may use it to translate addresses for non-MSP-defined RTD devices.

User Response: Review the devices specified in the command and re-issue the command if they are incorrect.

SMC0130

TAPEPLEX PPPPPPP1 has same LOCSUBSYS SSSS as TAPEPLEX
PPPPPPP2 [at line nnnn of SMCCMDS|SMCPARMS]

Level: 0

Explanation: A TAPEPLEX command was issued with a different TapePlex name PPPPPPP1 but the same LOCSUBSYS name as an existing TapePlex PPPPPPP2.

System Action: The TAPEPLEX command is not executed.

User Response: Correct the error and resubmit the command.

SMC0131

Cannot use [TAPEPLEX|SUBSYSTEM] CCCCCC from user exit or
POLICY; RRRRRRRR

Level: 4

Explanation: The TapePlex name on an SMC POLICY, or the TapePlex or SUBSYSTEM name from a user exit, was not used by the SMC for the specified reason RRRRRRRR.

System Action: The SMC uses other criteria to establish library ownership. Other data from the policy or exit is honored.

User Response: Correct the condition specified by RRRRRRRR.

SMC0132

Mount retry limit exceeded for volser=VVVVVV device=XXXX from
TAPEPLEX=PPPPPPP SERVER=SSSSSSS

Level: 4

Explanation: When SMC mount or mount TAPEREQ retrieval processing determines that an MSP mount is still pending and should be retried, it waits before attempting the retry. After the mount or mount policy retrieval retry limit is reached, the SMC0132 message is displayed.

System Action: The SMC will not continue to process the mount request after this message is issued.

User Response: Investigate the cause of the HSC mount problem. After resolving the problem, issue the SMC RESYNChronize REStart command or the HSC MOUNT command if necessary.

SMC0133

```
TAPEPLEX | STORMNGR=PPPPPPP
CCCC...CCCC
Status={disabled|active|inactive|never active}
Requests=nnnn
[SERVER=SSSSSSS
Status={disabled|active|inactive|never active}]
```

Level: 0

Explanation: A TAPEPlex or STORMNGR command was issued with the LIST keyword. The SMC0133 multiline message lists parameters and status for each TapePlex or STORMNGR defined to the SMC subsystem. Optionally, if the SERVerlist keyword was specified, the server status for all servers associated with this TapePlex or STORMNGR is also displayed.

TapePlex **status** indicates the status of the TapePlex or STORMNGR.

- **disabled** indicates that the TapePlex or STORMNGR has been disabled by an operator command.
- **active** indicates that the last communication to this TapePlex or STORMNGR was successful.
- **inactive** indicates that a communication path to this TapePlex or STORMNGR is no longer active, although one was previously active.
- **never active** indicates that a communication path to this TapePlex or STORMNGR was never successfully established.

Requests indicates the total number of requests (configuration, volume lookup, mount, dismount, and swap) that were directed to the specified TapePlex or STORMNGR.

If the SERVER keyword was specified, then each server path defined for this TapePlex or STORMNGR will also be displayed, along with its status.

System Action: None.

User Response: None.

SMC0134

No UNITATTR in effect for device(s) XXXX1[-XXXX2]

Level: 0

Explanation: Either no UNITATTR command was entered for the device, or a previously entered UNITATTR command was overridden by information from a TapePlex.

System Action: If the UNITATTR OFF parameter was specified, the device is not processed.

User Response: None.

SMC0135

{Mount/dismount message|Client response WTOR message|WTOR message issued by server} from TAPEPLEX=PPPPPPPP SERVER=SSSSSSSS

SMC0136

HSC mount or dismount message

Level: 4

Explanation: The WTORDEST(CLIENT) or ECHOMNTERR(ON) option is in effect. A mount or dismount was performed on an HSC TapePlex but did not complete successfully. The SMC0135 message indicates the TapePlex name and server name where the mount or dismount was requested. The SMC0136 merely echoes the HSC server mount or dismount message on the SMC client.

System Action: None.

User Response: Correct the problem indicated in the HSC mount or dismount message.

Note – Messages SMC0135 and SMC0136 are issued for all mount errors if the message level is 12 or greater, regardless of the WTORDEST or ECHOMNTERR setting, and for all HSC mount and dismount messages if the message level is 16 or greater.

SMC0137

HSC mount or dismount WTOR message

Level: 4

Explanation: A mount or dismount was performed on an HSC TapePlex with the TAPEPlex WTORDEST(CLIENT) set. HSC issued a WTOR that is to be handled by the client. The SMC0135 message indicates the TapePlex name and server name where the mount or dismount was requested.

System Action: The SMC redrives the mount or dismount to the server, transmitting the specified message response.

User Response: See the *HSC Messages and Codes Guide* for the corresponding HSC message, and respond as directed.

Note – The MSGDef command SMCWtorpfx parameter can be used to suppress the SMC0137 portion of the message.

SMC0138

XML {input|output} parse error RC=nnn; transaction=TTTTTTTTT
TAPEPLEX|STORMNGR=PPPPPPPP

Level: 0

Explanation: The SMC encountered an XML parse error. Input XML errors are produced when the input XML transaction cannot be parsed. Output XML errors occur when transaction response data cannot be converted to XML.

System Action: Depending upon the type of error, and server characteristics, the allocation or mount event may not be processed by the SMC.

User Response: Contact StorageTek Software Support.

SMC0139

UNITATTR for device XXXX MODEL=MMMMMMMMM [TAPEPLEX=PPPPPPPP]

Level: 0

Explanation: A UNITATTR command was issued with the LList parameter. The model and TapePlex associated with the device are displayed.

System Action: None.

User Response: None.

SMC0142

Invalid reply to prior message from TAPEPLEX=PPPPPPPP SERVER=
SSSSSSSS

Level: 0

Explanation: The WTORDEST(CLIENT) option was specified for TapePlex PPPPPPPP, and SMC has communicated a mount or dismount request to HSC via server SSSSSSSS. When SMC attempted to redrive the request, HSC returned an indication that the response was invalid.

System Action: SMC redisplays the HSC message.

User Response: Refer to the *HSC Messages and Codes Guide* for the valid responses for the indicated message.

SMC0143

UNITATTR MODEL=MMMMMMM1 cannot override real MODEL MMMMMMM2
for TAPEPLEX=PPPPPPPP device=XXXX

Level: 0

Explanation: A UNITATTR was specified for device XXXX specifying model MMMMMMM1. However, when the configuration query information was returned from TapePlex PPPPPPPP, the actual model was MMMMMMM2.

System Action: The SMC sets the recording technique for the device based on the actual model returned from the configuration query response. Processing continues.

User Response: Verify that any maintenance for new device types has been applied to all NCS products, including SMC, or issue an SMC UNITAttr command for the device specifying the correct model information.

SMC0144

Mount of volser=VVVVVV on device=XXXX; drive is in use; reply 'C' to cancel mount or 'R' to retry

Level: 0

Explanation: SMC has communicated a mount or dismount request to HSC. HSC has responded with a message indicating that the drive is in use.

System Action: If the mount is still outstanding, the SMC automatically redrives the mount every 30 seconds. The message is DOMed if the mount is no longer pending, or the drive becomes available.

User Response: Wait for the drive to become available, or reply 'C' to cancel the request, or 'R' to retry immediately.

SMC0145

Mount of volser=VVVVVV on device=XXXX; volume is in use; reply 'C' to cancel mount or 'R' to retry

Level: 0

Explanation: SMC has communicated a mount or dismount request to HSC. HSC has responded with a message indicating that the drive is in use.

System Action: The SMC verifies that the mount is still outstanding. If the mount is still outstanding, the SMC automatically redrives the mount every 30 seconds. The message is DOMed if the mount is no longer pending, or the volume becomes available.

User Response: Wait for the volume to become available, or reply 'C' to cancel the request, or 'R' to retry immediately.

SMC0146

All devices marked ineligible for job JJJJJJJJ step SSSSSSSS due to volume lookup failure

Level: 4

Explanation: When SMC allocation attempted to acquire volume information, a communication failure with the library server occurred. The ALLOCDEF option FAILNOINFO was specified.

System Action: The SMC marks all devices as ineligible for allocation. The job is failed by MSP or express-canceled by JES.

User Response: Investigate the cause of the communication failure and resubmit the job.

SMC0147

PPPPPPP1 is incompatible with PPPPPPP2 on the TAPEREQ command line nnnn of TREQDEF DSN

Level: 0

Explanation: An incompatibility exists between PPPPPPP1 and PPPPPPP2 at line nnnn in the data set specified on the TREQDEF command.

System Action: The SMC continues to process the TAPEREQ statements, flagging additional errors.

User Response: Correct the errors and re-issue the TREQDEF command.

SMC0149

TREQDEF specifications not installed, reason code *nn*

Level: 0

Explanation: The TAPEREQ statements in the data set specified on the TREQDEF command were not installed.

08 - Syntax error on a TAPEREQ statement

12 - The TAPEREQ structure has not been initialized

System Action: None.

User Response: Correct the errors and re-issue the TREQDEF command.

SMC0150

TREQDEF specifications installed from *DDDDDDDD*

Level: 0

Explanation: The TAPEREQ statements in the data set specified on the TREQDEF command were successfully installed.

System Action: None.

User Response: None.

SMC0151

TREQDEF status:

Loaded from *DDDDDDDD*

Title: *TTTTTTTT*

{Loaded on *YYYY-MM-DD* at *HH:MM:SS*|

Not active due to error; process RC=*nn*}

Level: 0

Explanation: The TREQDEF command was issued with the LIST keyword. The current TAPEREQ statements were loaded from data set *DDDDDDDD*. The title *TTTTTTTT* is displayed if one was specified in the OPTION statement. If there was no currently active TREQDEF file due to an error, the message "not active due to error" is displayed but the data set name last used for the TREQDEF is available and can be used in the TREQDEF RELOAD command.

System Action: None.

User Response: None.

SMC0152

TREQDEF DSN command has not been previously issued

Level: 0

Explanation: The TREQDEF LIST or RELOAD commands have been specified without a prior TREQDEF DSN command.

System Action: None.

User Response: Issue a TREQDEF command with the DSN keyword prior to issuing the TREQDEF with the LIST or RELOAD keyword.

SMC0153

Dynamic allocation failed for DDDDDDDD

Level: 0

Explanation: Data set name DDDDDDDD, specified in a READ command, could not be allocated by the SMC.

System Action: The command is not processed.

User Response: Review the specified data set name to ensure that it is a cataloged MSP data set, and re-issue the command.

SMC0154

UNITATTR model MMMMMMMM ignored for TAPEPLEX device XXXX

Level: 0

Explanation: A UNITATTR command has been issued specifying device XXXX. The device is defined to a TapePlex known to SMC. The SMC obtains the device model from the TapePlex.

System Action: The UNITATTR command does not process the device.

User Response: None.

SMC0155

LOG settings:
CCCC...CCCC
Logging currently {INACTIVE|ACTIVE}

Level: 0

Explanation: A LOG command was issued with the LIST keyword. The SMC0155 multiline message lists the current settings and status for the SMC subsystem. Refer to the LOG command for parameter descriptions.

In addition, a log status of ACTIVE indicates that logging has been started; INACTIVE indicates that logging has not been started, or has been stopped at EOF.

System Action: None.

User Response: None.

SMC0156

SMCLOG file is not currently opened

Level: 0

Explanation: A LOG command has been issued with the STOP keyword. However logging is not currently active.

System Action: The LOG command is ignored.

User Response: None.

SMC0157

SMCLOG file is already opened

Level: 0

Explanation: A LOG command has been issued with the START keyword. However, the logging is already active.

System Action: The LOG command is ignored.

User Response: None.

SMC0158

No SMCLOG DD; logging cannot be started

Level: 0

Explanation: A LOG command has been issued with the START keyword. However, there was no SMCLOG DD in the SMC subsystem startup JCL.

System Action: The LOG command is ignored.

User Response: Add an SMCLOG DD to the SMC subsystem startup JCL, then restart the SMC subsystem.

SMC0159

Logging {started|stopped}

Level: 0

Explanation: A LOG command has been issued with the START or STOP keyword.

System Action: SMC logging is started or stopped.

User Response: None.

SMC0160

Invalid range XXXX1-XXXX2 for keyword ADDRESS of the UNITATTR command

Level: 0

Explanation: A UNITATTR command has been issued specifying a device range XXXX1-XXXX2, where XXXX1 is larger than XXXX2.

System Action: The UNITATTR command does not process this device range.

User Response: Reissue the command specifying a valid range.

SMC0161

Restoring all default settings for the CCC...CCC command

Level: 0

Explanation: The CCC...CCC command has been issued with the OFF parameter. All SMC values have been restored for the SMC subsystem.

System Action: None.

User Response: None.

SMC0162

CCC...CCC object successfully {added|updated|deleted}

Level: 0

Explanation: The CCC...CCC command has been successfully processed.

System Action: None.

User Response: None.

SMC0163

DRIVEMAP settings:
CLIENT=XXXX1{-XXXX2} SERVER=XXXX3{-XXXX4}

Level: 0

Explanation: A DRIVEMAP command has been issued with the LIST keyword. The SMC0163 multiline message lists the currently active DRIVEMAPs. One line is produced for each client/server range.

System Action: None.

User Response: None.

SMC0164

CLIENT range XXXX1{-XXXX2} not found for the OFF keyword of the DRIVEMAP command

Level: 0

Explanation: The DRIVEMAP command has been issued with the OFF parameter and CLIENT parameter. No matching DRIVEMAP range matching the CLIENT parameter was found.

System Action: None.

User Response: None.

SMC0165

Keyword {CLIENT/SERVER} range XXXX1{-XXXX2} overlaps with previous DRIVEMAP entry

Level: 0

Explanation: A DRIVEMAP command was issued containing a client or server range that overlaps a range specified on a previously issued DRIVEMAP command.

System Action: The DRIVEMAP command is not processed.

User Response: Issue the DRIVEMAP LIST command to view the list of currently active DRIVEMAP ranges. Correct the DRIVEMAP command to specify a new range. Or, use the DRIVEMAP CLIENT(XXXX1-XXXX2) OFF command to de-activate the existing overlapping range and re-specify the command with unique ranges.

SMC0166

Excessive READ depth at line *nn* of DSN *DDDDDDDD*

Level: 0

Explanation: A READ command was issued from a file. However, too many command files are already open, and the read command depth has been exceeded. Read command depth is defined as the number of files that can be open simultaneously due to imbedded Read commands.

System Action: The READ command is not processed.

User Response: Restructure your command files to reduce the READ command depth and ensure that the files referenced do not contain a recursive loop.

SMC0167

```
CCCCCC summary:
TAPEPLEX|STORMNGR PPPPPPP is {disabled|inactive|active on
{local subsystem SSSS|server SSSSSSSS}
{All TAPEPLEX|STORMNGR(s) active|
n of n TAPE TAPEPLEX|STORMNGR(s) active|
WARNING: All TAPEPLEX|STORMNGR(s) inactive|
WARNING: No TAPEPLEX|STORMNGR(s) defined|
WARNING: No TAPEPLEX|STORMNGR(s) enabled}
```

Level: 0

Explanation: The CCCCCC command was issued and a TapePlex and STORMNGR resynchronization was performed. Each TapePlex is represented by a line in the multiline WTO displaying its status.

System Action: None.

User Response: None.

SMC0168

WARNING: No TREQDEF command processed

Level: 4

Explanation: No TREQDEF command was found in the SMCPARMS or SMCCMDS file at startup.

System Action: TAPEREQ processing is not performed for allocation or mount requests.

User Response: If your installation previously specified TREQDEF in HSC, issue the TREQDEF command to SMC and add the TREQDEF command to the SMCCMDS (or SMCPARMS) file.

SMC0169

WARNING: {SMCCMDS|SMCPARMS} processing TIMEOUT; startup continuing

Level: 4

Explanation: During SMC subsystem startup, startup command processing could not complete the indicated command file.

System Action: The SMC continues startup processing, but not all startup commands may have been processed.

User Response: None.

SMC0170

{Request timeout|SMC subsystem terminating}; request to subsystem SSSS aborted

Level: 4

Explanation: The SMC issued a request to subsystem SSSS, but no response was received within the time limit, or the SMC subsystem was terminated.

System Action: The SMC continues processing without waiting for the HSC response. In addition, if a request timeout is indicated, the SMC server path to the specified subsystem is disabled.

User Response: Check the status of the subsystem that is not responding to SMC, and correct the problem. After correcting the problem, enable the appropriate server path.

SMC0171

Allocatability test matrix retries exceeded

Level: 0

Explanation: The SMC could not determine allocatability of the jobstep using its test matrix in the calculated number of retries.

System Action: Normally, processing continues, with SMC "backing out" exclusion conditions until the jobstep is allocatable.

User Response: If possible, rerun the job with allocation trace turned on. Save trace and log output, and contact StorageTek Software Support.

SMC0172

Specified TAPEPLEX|STORMNGR P P P P P P P P not
{defined|HSC|active|enabled|valid for UUI}

Level: 0

Explanation: An SMC command was issued specifying TAPEPLEX or STORMNGR P P P P P P P P. However, the command cannot be completed because the TAPEPLEX or STORMNGR is either not defined to the SMC, or is not eligible.

System Action: The command is not processed.

User Response: Either name a valid TAPEPLEX or STORMNGR, or correct the TAPEPLEX or STORMNGR status and reissue the command.

SMC0173

Response from TAPEPLEX|STORMNGR PPPPPPPP:
 CCCC...CCCC
 Response RC=nn

Level: 0

Explanation: An SMC Route command was issued that specified TAPEPlex or STORMNGR PPPPPPPP. The SMC0173 message lists the TAPEPLEX or STORMNGR name, followed by the response from the specified TAPEPLEX or STORMNGR, terminated by an SMC0173 message displaying the command return code.

System Action: None.

User Response: None.

SMC0174

ASCOMM ACK timeout for job=JJJJJJJJ (DS=nnnn-nnnn)

Level: 0

Explanation: The SMC replied to a request from job JJJJJJJJ, but no acknowledgment was received within the time limit.

System Action: The SMC continues processing without waiting for the acknowledgment.

User Response: None.

SMC0175

Communication initialized on TAPEPLEX|STORMNGR=name {SERVER=
 name}

Level: 4

Explanation: The SMC has successfully communicated with the specified TapePlex or STORMNGR for the first time. Additionally, if the communication path selected was a remote server, then the server is also displayed.

System Action: Processing continues.

User Response: None.

Note – This message is produced each time communication switches from one server to another, or communication is re-established after an error.

SMC0176

No active TAPEPLEX(s) for DISPLAY command

Level: 0

Explanation: A DISPLAY command has been entered. However, the SMC cannot establish communication with any TapePlex.

System Action: If the DISPLAY (or QUERY) VOLUME command was entered, the command terminates as there are no TapePlexes to direct the request. If the DISPLAY DRIVE command was entered, the command continues although the drive information displayed may not reflect TapePlex ownership.

User Response: None.

SMC0177

```
SMC DISPLAY VOLUME
Volser TapePlex Location Media Rectech Volume Data
-----
VVVVVV PPPPPPPP {AA:LL} MMMMMMMM RRRRRRRR DDDDDDDD
```

Level: 0

Explanation: A Display Volume command was entered. The SMC0177 message(s) lists the volsers that match the request. If ALLtapeplex parameter was specified, duplicate volsers, if found, are listed beginning with an asterisk (*). The displayed Rectech for a volume reflects a combination of the volume's media type, VOLATTR (if any), and volume data such as density. For example, a volume with a RECTECH of STK1RC may have either a VOLATTR that specifies a RECTECH of STK1RC for the volume, or may be known to have been mounted as scratch on a 9840C drive. The Volume Data for a volume reflects known characteristics of the volume as stored in the HSC CDS, such as volume density.

System Action: None.

User Response: None.

SMC0178

```
SMC DISPLAY DRIVE
Addr Location Model SMC Status MSP Status
-----
CCUU PPPPPPPP AA:LL:PP:DD MMMMMMMM XXXX-VVVVVV SSSSSSSSS
```

Level: 0

Explanation: A DISPLAY DRIVE command has been entered. The SMC0178 message(s) lists the device addresses that match the request. XXXX is the last SMC mount/dismount for the drive. VVVVVV is the last volume serial mounted or dismounted. PPPPPPPP is the TapePlex.

Note that the status of DISM will be displayed after a dismount is issued until another volume is mounted on the drive.

System Action: None.

User Response: None.

SMC0179

```
{TAPEPLEX|ESOTERIC} XXXXXXXX not defined for POLICY PPPPPPPP
```

Level: 0

Explanation: During policy verification, the SMC detected undefined TapePlex or ESOTERIC names on POLICY statements, or detected that a specified TapePlex was disabled.

System Action: None.

User Response: Correct the POLICY ESOTERIC or TapePlex name and re-enter the POLICY.

SMC0180

```

POLICY=CCCCCCCC {scr only|spec only|scr + spec|scr error|
spec error|in error|scr defined|spec defined}
Scratch policy: (displays entered policy values)
Specific policy: (displays entered policy values)
Created on mmm dd yyyy hh:mm:ss
[at line nnn of dsname| from console userid]
Changed on mmm dd yyyy hh:mm:ss
[at line nnn of dsname| from console userid]

```

Level: 0

Explanation: A POLICY LIST command was received. If the TERse option is specified, only the first line is displayed for each policy. The Created and Changed data are displayed only if the DETail option is entered.

System Action: None.**User Response:** None.**SMC0181**

```

WARNING: SMS MGMTPOL specified and no POLICY statements
defined

```

Level: 8

Explanation: ALLOCDef SMS option and SMSDef MGMTPol option are both on, but no POLICY commands were processed at startup.

System Action: None.

User Response: Provide policy definitions for policy names specified on DFSMS ACS management class routines.

SMC0182

```

POLICY CCCCCCCC not defined for TREQDEF statement nnnn

```

Level: 8

Explanation: During validation of the TREQDEF data set, a TAPEREQ statement specified a policy name CCCCCCCC that did not match a defined POLICY.

System Action: The TREQDEF definitions are rejected.

User Response: Ensure that POLICY commands are processed before the TREQDEF command, or change the TAPEREQ statement to correct the POLICY name.

SMC0183

```

POLICY CCCCCCCC not found in any TAPEREQ statement

```

Level: 8

Explanation: During policy validation, the SMC found a policy name CCCCCCCC that was not specified on any TAPEREQ statement.

System Action: None.

User Response: Remove the inactive POLICY statement, or specify the policy name on a TAPEREQ statement.

SMC0184

{Specific|Scratch} POLICY CCCCCCCC marked in error

Level: 0

Explanation: A POLICY that is to be added to the SMC contains a policy specification error, for instance, specifying a scratch SUBPOOL name with VOLTYPE(SPECIFIC).

System Action: Processing continues. The SMC creates the named POLICY object. However, the SMC marks the POLICY object in error, allowing any reference to the named POLICY object to find it. In such cases however, the returned POLICY will be empty, indicating that default tape policy attributes will be applied to the allocation or mount event.

User Response: Correct and reissue the POLICY command.

SMC0185

Non-POLICY TAPEREQ statements detected

Level: 8

Explanation: One or more TAPEREQ statements did not specify a POLICY keyword. It is recommended that you convert existing TAPEREQ statements to POLICY format.

System Action: None.

User Response: Convert TAPEREQ statements to use POLICY format.

SMC0187

WARNING: Could not find device XXXX for TAPEPLEX PPPPPPPP specified in UNITATTR

Level: 0

Explanation: A UNITATTR was specified for device XXXX as belonging to TAPEPLEX PPPPPPPP. However, the returned configuration query did not contain the specified device.

System Action: None. The SMC honors the UNITATTR. Depending upon when the server processes the configuration query during its startup, not all devices may be returned in the configuration query response.

User Response: Verify that the specified device actually belongs to the specified TAPEPLEX.

SMC0188

Non-virtual MEDIA or RECTECH is not allowed with MGMTCLAS

Level: 0

Explanation: A POLICY statement was entered that specified a MGMTCLAS with a non-virtual MEDIA and/or RECTECH. However, MGMTCLAS should be specified only for virtual policies.

System Action: The POLICY is rejected.

User Response: Correct the POLICY and reissue the POLICY command.

SMC0189

CCCCCCC entry EEEEEEE not found for {list|update|delete}

Level: 0

Explanation: A CCCCCCC command was entered specifying that entry EEEEEEE be either listed, deleted, or updated. However, no entry matching EEEEEEE was found.

System Action: None.

User Response: Issue the CCCCCCC command with the LIST option to list all CCCCCCC entries. Then re-issue the command specifying the correct entry name.

SMC0190

CCCCCCC 0000000 set to {ON|OFF|XXXXXXXX}

Level: 0

Explanation: A CCCCCCC command was entered specifying that option 0000000 be set to ON, OFF, or the specified value XXXXXXXX. If multiple options were specified on a single CCCCCCC command, then multiple SMC0190 messages are issued, one for each specified option.

System Action: None.

User Response: None.

Note – SMC0190 messages are displayed only if MSGDef VERBose(ON) is specified.

SMC0191

CCCCCCC 0000000 set to {ON|OFF|XXXXXXXX} for entry EEEEEEE

Level: 0

Explanation: A CCCCCCC command was entered specifying that option 0000000 be set to ON, OFF, or the specified value XXXXXXXX for the CCCCCCC entry EEEEEEE. If multiple options were specified on a single CCCCCCC command, then multiple SMC0191 messages will be issued, one for each specified option.

System Action: None.

User Response: None.

Note – SMC0191 messages are displayed only if MSGDef VERBose(ON) is specified.

SMC0192

Specific volume lookup failure(s) occurred for job JJJJJJJJ

Level: 4

Explanation: During allocation processing for a specific volume in job JJJJJJJJ, volume lookup indicated a communication failure. The ALLOCDef FAILNOINFO option was not specified.

System Action: Processing continues. Allocation may be directed to a device incompatible with the volume.

User Response: Determine and correct the cause of the communication failure.

SMC0193

Scratch volume lookup failure(s) occurred for job *JJJJJJJJ*

Level: 8

Explanation: During allocation processing for a scratch volume in job *JJJJJJJJ*, volume lookup indicated a communication failure. ALLOCDef FAILNOINFO was set to OFF or SPECIFIC.

System Action: Allocation proceeds using policies specified in POLicy, TAPEREQ, user exit, or DFSMS ACS routines.

User Response: Determine and correct the cause of the communication failure. Ensure that policy information is adequate to allocate scratch volumes to the appropriate TapePlex and media.

SMC0194

TAPEPLEX *PPPPPPPP* from [POLICY|user exit] conflicts with
ESOTERIC *EEEEEEEE* from [POLICY/TAPEREQ|user exit] for job
JJJJJJJJ

Level: 8

Explanation: The TapePlex name provided by the SMC POLicy or user exit is different from that implied by the esoteric name in the POLicy/TAPEREQ or user exit.

Note – SMC0194 messages are displayed only if SMC MSGDef VERBose(ON) specified.

System Action: The SMC determines which TapePlex should be used for volume information based first on the POLicy TapePlex, then on the POLicy or TAPEREQ esoteric name (if all drives in the esoteric reside in a single library), next on the user exit TapePlex or subsystem name, and finally on the TapePlex implied by the esoteric returned from the user exit. The esoteric name will still be used in the drive exclusion process, even if it conflicts with the policy or user exit TapePlex name.

User Response: Review the applicable POLicy, TAPEREQ, and user exit values to be sure that the intended policies are being specified.

SMC0195

READ processing started for {SMC PARMS|SMCCMDS|*data set name*}

Level: 0

Explanation: The SMC has begun processing commands in the named file.

Note – SMC0195 messages are displayed only if SMC MSGDef VERBose(ON) specified.

System Action: None.

User Response: None.

SMC0196

READ processing complete; RC=*nn*
 from {SMCPARMS|SMCCMDS|*data set name*}

Level: 0

Explanation: The SMC has completed processing commands in the named file. The highest return code for any command is *nn*.

System Action: None.

User Response: None.

SMC0197

WARNING: POLICY *PPPPPPPP* is specified; ignoring {esoteric
 subpool|subsystem|TapePlex} from user exit for job *JJJJJJJJ*

Level: 8

Explanation: An allocation user exit returned esoteric, subpool, TapePlex or subsystem data, but policy *PPPPPPPP* is in effect.

System Action: Since the policy is the only source for the information, the data returned from the user exit is ignored.

User Response: Ensure that the named policy contains all policy information that should apply.

SMC0200

ALLOC event ignored

Level: 8

Explanation: A READ command was specified from the SMC that required SMC tape allocation services.

System Action: None.

User Response: Issue the READ command for a disk data set.

SMC0201

{TAPEREQ|CONTROL} statements can only be input using the
 TREQDEF command

Level: 0

Explanation: TAPEREQ control statements were read using the SMC READ command instead of the TREQDEF command.

System Action: None.

User Response: Issue the TREQDEF command to read the TAPEREQ control statements.

SMC0202

Update error not applied because {SCRATCH|SPECIFIC} POLICY for entry *PPPPPPPP* already exists.

Level: 0

Explanation: An erroneous POLICY statement was entered. The update error was not applied because the SCRATCH or SPECIFIC policy already exists. If the SCRATCH or SPECIFIC policy did not exist, the POLICY would have been entered and flagged as an error.

System Action: None.

User Response: Correct and reissue the POLICY command.

SMC0203

```

COMMTEST:
JOB=JJJJJJJJ IIIIIIII TASK=XXXXXXXXXXXXXXXXX {MSG=XXXXXXXX}
TAPEPLEX|STORMNGR=LLLLLLLL {SUBSYSTEM=AAAA|SERVER=SSSSSSS}
REQUEST=FFFF
{Client {IP=NNN.NNN.NNN.NNN} socket=NN port={nnnn|ANY}}
{Server IP=NNNN.NNNN.NNNN.NNNN port=nnnn}
{Bytes out=nnnn in=nnnn}
{Error=EEEE...EEEE}
{Reason=RRRR...RRRR}
{Response from STK HTTP server follows: HHHH...HHHH}
Current LIBPATH status={active|inactive|never active|disabled}
SMC comm RC=nnnn elapsed time=nn.nn
    
```

Level: 0

Explanation: A COMMtest command was entered. The SMC0203 message is displayed for each communication path attempted.

System Action: None.

User Response: None.

SMC0204

No eligible COMMPATH(s) found

Level: 0

Explanation: A COMMtest command was entered, but the specified TAPEplex, STORMNGR, SERVer, and status parameters resulted in no eligible communication paths selected for the test.

System Action: None.

User Response: Correct and reissue the COMMtest command.

SMC0205

Disabling bind to PORTRANGE *nnnn-nnnn*; any ephemeral port will be used

Level: 0

Explanation: A TCPip PORTrange (OFF) command was entered. Sockets will no longer be bound to the fixed port range of *nnnn-nnnn*, but any ephemeral port will be used.

System Action: None.

User Response: None.

SMC0206

No PORTRANGE currently defined

Level: 0

Explanation: A TCPip PORTrange (OFF) command was entered but there is currently no active PORTrange specified to disable.

System Action: None.

User Response: None.

SMC0207

Specified SERVER *SSSSSSSS* not {found|defined for TAPEPLEX | STORMNGR=*TTTTTTTT*}

Level: 0

Explanation: A COMMtest command was entered specifying a specific TapePlex or STORMNGR and server. However, the server is either not defined to the SMC, or is not defined for the specified TapePlex or STORMNGR.

System Action: None.

User Response: Correct and reissue the COMMtest command.

SMC0208

NEW TAPEPLEX=*PPPPPPP1* MODEL=*MMMMMMMM1* for device *XXXX*
OLD TAPEPLEX=*PPPPPPP2* MODEL=*MMMMMMMM2*

Level: 0

Explanation: A configuration query response from TapePlex *PPPPPPP1* was received for device *XXXX* that either changed the TapePlex ownership from TapePlex *PPPPPPP2*, or its model type from model *MMMMMMMM2* to *MMMMMMMM1*.

System Action: Processing continues. The SMC sets the TapePlex ownership and model to the new values.

User Response: This message most likely indicates that the same device address is defined to two or more TapePlexes, and the configuration information received from one TapePlex has been superseded by that of the other TapePlex. In this case, issue a UNITAttr command for the device specifying which TapePlex is the owner of the device on this host.

SMC0226

Path switch from SERVER=SSSSSSSS to PPPPPPPP for
TAPEPLEX | STORMNGR=TTTTTTTT

Level: 4

Explanation: The SMC automatically switched the communication path from the secondary server SSSSSSSS to the primary server PPPPPPPP for TapePlex or STORMNGR TTTTTTTT.

System Action: Processing continues.

User Response: None.

SMC0241

WARNING: STORMNGR entry SSSSSSSS has no SERVER(s) defined

Level: 0

Explanation: A STORMNGR command was entered during the SMC startup process. After all commands were processed from the SMCPARMS and SMCCMDS data sets, the named STORMNGR does not have associated SERVER communication paths defined.

System Action: This message results in a return code 8 at SMC startup and may prevent the SMC from initializing if the SMCBINT program parameter MAXRC(0|4) is specified.

User Response: Add the SERVER definitions to the SMCCMDS or SMCPARMS data sets after the STORMNGR definition.

SMC0242

Cannot add STORMNGR CCC...CCC before TAPEPLEX(es)

Level: 0

Explanation: STORMNGR commands must be entered after TAPEPLEX commands.

System Action: Processing continues.

User Response: Enter TAPEPLEX commands before STORMNGR commands.

SMC0243

CCCCCCC command specifies {TAPEPLEX|STORMNGR} NNNNNNNN; but
NNNNNNNN is a {STORMNGR|TAPEPLEX} [at line NNNN of
{SMCCMDS|SMCPARMS}]

Level: 0

Explanation: The CCCCCCC command was entered and specified the named TapePlex or Storage Manager. However, name NNNNNNNN is not the type of entity described.

System Action: The command is not processed.

User Response: Change the entity type from TAPEPLEX to STORMNGR or vice versa, and reissue the command.

SMC0260

TAPEPLEX|STORMNGR CCCCCCC commpath PPPPPPP inactive; RC=RRRR,
EEEEEEEEEEEE

Level: 0

Explanation: SMC is unable to communicate to the TAPEPLEX or STORMNGR using the specified commpath *PPPPPPP*, where *PPPPPPP* is the server name or (local). The value RRRR is the decimal return code, with a translated explanation *EEEEEEEEEEEE*.

System Action: The message is issued for each defined local commpath or SERVER and is non-scrollable as long as SMC is unable to communicate with the TAPEPLEX.

User Response: Correct the reported error for at least one communication path.

SMC0261

TAPEPLEX|STORMNGR CCCCCCC inactive; no available communication
paths

Level: 0

Explanation: The TAPEPLEX or STORMNGR CCCCCCC has no defined communication paths, or all paths have a disabled status.

System Action: No communication is attempted to the TAPEPLEX or STORMNGR.

User Response: Add a communication path, or enable an existing local path or SERVER.

SMC9999

MMMMMMMM Variable text

Level: 12, 16, 20, 24, 28

Explanation: SMC9999 messages are intended for StorageTek Software Support problem determination and resolution. *MMMMMMMM* is the name of the issuing module.

System Action: None.

User Response: None. A message level (LVL) of 12 or higher should generally be specified only when directed by StorageTek Software Support.

SMC Utility Message Listing

SMCU0008

SMCUDBX input parameter error

Explanation: An error was detected in the input PARM for the SMCUDBX utility. A detailed description of the error follows.

System Action: The utility processing terminates with a return code of 8.

User Response: Correct the indicated error and resubmit the job.

SMCU0009

Unable to load TMS interface routine
{SLUDRCA1|SLUDRTLML|SLUDRZAR}

Explanation: Based on the input TMS parameter, the SMCUDBX utility attempted to load the corresponding tape management access routine, but the load failed.

System Action: The utility processing terminates with a return code of 8.

User Response: Ensure that a load library containing the appropriate SLUDR* routine for your tape management system is available to the SMCUDBX utility through a JOBLIB, STEPLIB, or MSP LINKLIST library.

SMCU0010

Error opening file DDNAME DDDDDDDDD

Explanation: The utility was unable to open the DDNAME DDDDDDDDD.

System Action: The utility processing terminates with a return code of 8.

User Response: Correct the execution JCL to provide the required DD statement.

SMCU0011

Error processing ZARA interface for subsystem SSSS

Explanation: The user requested an extract from the ZARA tape management system with subsystem ID CCCC. A detailed description of the error follows the message.

System Action: The utility processing terminates with a return code of 8.

User Response: Correct the indicated error and resubmit the job.

SMCU0012

Unexpected return code XXXX from TMS interface

Explanation: An unexpected return code XXXX was received from the TMS extract routine.

System Action: The utility processing terminates with a return code of 8.

User Response: If user modifications have been made to the TMS extract routine, correct the routine. Otherwise, contact StorageTek Software Support for assistance.

SMCU0013

No VLF control record found by SLUDRTL

Explanation: The user specified TLMS as the SMCUDBX tape management system, but the input file did not contain a CA-DYNAM/TLMS VLF record.

System Action: Utility processing terminates with a return code of 8.

User Response: Verify that the correct input file was specified on the DBTMS DD statement, and resubmit the job.

SMCU0014

Error reading file DDNAME DDDDDDDD [;unterminated
{comment|continuation} line detected]

Explanation: The utility detected an I/O error or system error on the named data set.

System Action: Utility processing terminates with a return code of 8.

User Response: Correct the error and resubmit the job.

SMCU0015

DDNAME DDDDDDDD is required; cannot continue

Explanation: The named DD name is required based on the input request.

System Action: Utility processing terminates with a return code of 12.

User Response: Supply the required DD statement and resubmit the job.

SMCU0016

Processing complete; UUI commands processed = nn, highest RC=
nn

Explanation: UUI processing has completed.

System Action: None.

User Response: None.

SMCU0017

Error processing program PARMS; *error description*

Explanation: The utility program PARM contained an error.

System Action: Utility processing terminates with a return code of 12.

User Response: Correct the error and resubmit the job.

SMCU0020

CSV parsing error; [error text]

Explanation: The UUI IN CSV command contained a syntax error.

System Action: The request(s) following the CSV command is not processed.

User Response: Correct the error and resubmit the job.

SMCU0021

UUI command bypassed due to previous CSV error

Explanation: A UUI request followed a CSV command that contained a syntax error.

System Action: The request is not processed.

User Response: Correct the error and resubmit the job.

SMCU0022

CSV command ignored due to missing CSVOUT DD

Explanation: A CSV command was processed but no CSVOUT DD was specified for the SMCUUUI utility.

System Action: The CSV command is ignored. Subsequent requests are processed with no CSV output.

User Response: Supply the CSVOUT DD statement and resubmit the job.

SMCU0023

MMMMMMMM not executing from authorized library; cannot continue

Explanation: The SMC utility module *MMMMMMMM* was executed from a non-APF library, but requires APF authorization.

System Action: Program execution is terminated.

User Response: Ensure that the SMC link library is APF authorized.

Return Codes

UUI Return Codes

The following return codes are set by the SMC UUI Component for external user communication with a TAPEPLEX or with the SMC.

TABLE 11-1 General UUI Return Codes

Decimal Value	Hex Value	Description
1	1	More data to return
2	2	All data was returned (EOF)
4	4	Command issued warning message
8	8	Command issued error message
300	X'012C'	SMC not active
304	X'0130'	UUI unsupported in release
308	X'0134'	Request type invalid
312	X'0138'	Error acquiring new token
316	X'013C'	Module load error
320	X'0140'	Task attach error
324	X'0144'	No active TAPEPLEX for UUI
328	X'0148'	No TAPEPLEX or LVT addr
332	X'014C'	TAPEPLEX name not found
336	X'0150'	TAPEPLEX is disabled
344	X'0158'	Invalid TAPEPLEX addr
348	X'015C'	Invalid NCSCOMM PLIST
352	X'0160'	Invalid PLIST for OUTPUT
356	X'0164'	Inconsistent CSV parms
360	X'0168'	Token does not exist
364	X'016C'	No local HSC for LOCALHSC

TABLE 11-1 General UUI Return Codes (Continued)

Decimal Value	Hex Value	Description
368	X'0170'	Linklib not authorized
372	X'0174'	Parse error for remote XML
376	X'0178'	XML start tag not found
380	X'017C'	XML end tag not found
384	X'0180'	Error from SMC COMM... See HSC UUI messages and codes
388	X'0184'	Use local HSC for utility
392	X'0188'	Response length is 0
396	X'018C'	Response length too large
400	X'0190'	Requested service inactive
404	X'0194'	SMC service error inactive
408	X'0198'	File not found
412	X'019C'	File I/O error
416	X'01a0'	Max READ depth exceeded

SMC ASCOMM Return Codes

The following return codes are set by the SMC ASCOMM Component for MSP inter and intra address space communication.

TABLE 11-2 ASCOMM Return Codes

Decimal Value	Hex Value	Description
500	X'01f4'	SMC STOP command issued or task cancelled during communication
504	X'01f8'	Wrong version of SMCQASP
508	X'01fc'	At max SMCQUEE queue size
512	X'0200'	No GETMAIN storage
516	X'0204'	No dataspace storage
520	X'0208'	Invalid ASCOMM module index
524	X'020c'	QASTOKN acquisition error
528	X'0210'	Response timeout occurred
532	X'0214'	Final ACK timeout occurred
536	X'0218'	Indexed module not found
540	X'021c'	Asynch service already in progress, req bypassed
544	X'0220'	HSC timeout occurred
548	X'0224'	HSC error occurred
552	X'0228'	HSC abend occurred

SMC Communication Component Return Codes

The following return codes are set by the SMC TAPEPLEX Communication for local or remote communications.:

TABLE 11-3 SMC Communication Component Return Codes

Decimal Value	Hex Value	Description
600	X'0258'	No active COMMPATH
604	X'025c'	SSCVT invalidated by TapePlex command
608	X'0260'	Local HSC inactive
612	X'0264'	Local HSC not valid
616	X'0268'	Local HSC not on SSCVT
620	X'026c'	Local HSC release error

The following return codes are set by the SMC Communication Component TCP/IP routines:

TABLE 11-4 SMC Communication Component TCP/IP Routine Return Codes

Decimal Value	Hex Value	Description
700	X'02bc'	Invalid remote transaction
704	X'02c0'	CGI module not specified
708	X'02c4'	TCPIP setsockopt() error
712	X'02c8'	TCPIP socket() error
716	X'02cc'	TCPIP setsockopt() error
720	X'02d0'	No free port (SMCCTCPP)
724	X'02d4'	TCPIP bind () error
728	X'02d8'	TCPIP connect () error
732	X'02dc'	TCPIP send () error
736	X'02e0'	TCPIP recv () error
740	X'02e4'	TCPIP timeout error

The following return codes are set by the SMC CGI routines or the HTTP server routines:

TABLE 11-5 SMC CGI Routine/HTTP Server Routine Return Codes

Decimal Value	Hex Value	Description
800	X'0320'	HTTP task limit exceeded
804	X'0324'	CGI module not found
808	X'0328'	CGI module abended
812	X'032c'	CGI module not authorized
816	X'0330'	CGI module not supported
820	X'0334'	CGI module returned error
824	X'0338'	Remote HSC subsystem is incorrect release
828	X'033c'	Remote file I/O request not supported
996	X'03c4'	Unknown logic error

Using the StorageTek HTTP Server

Overview

The StorageTek HTTP Server for MSP provides the middleware to allow communication between the SMC (client) and a remote HSC subsystem (server). The HTTP server executes as a separate subsystem **on the remote HSC host**. It is **not** required on a host where only the SMC is executing.

This chapter includes information used to initialize and configure the StorageTek HTTP Server. The following topics are included:

- Customizing the HTTP Server START Procedure
- Security Administration Considerations for Communication
- Customizing the HTTP Server Parameter File
- Starting the HTTP Server
- Stopping the HTTP Server
- Displaying HTTP Server Status
- Tracing the SMC in the HTTP Server
- HTTP Server Messages

Note –

- Refer to the *NCS Installation Guide* for information about installing the StorageTek HTTP server.
 - The StorageTek HTTP server is also included with the Virtual Storage Manager (VSM) GUI product. However, for performance and security reasons, it is recommended that you not use the same instance of the HTTP server for both SMC server programs and VSM GUI programs. To execute multiple HTTP server subsystems on a single host, they must each listen on a unique PORT number.
-

Creating the HTTP Server START Procedure

The HTTP server must be started on the same host as the HSC that will function as a remote server. It is not necessary to execute the HTTP server on client hosts running only SMC and not HSC.

To create the HTTP server START procedure, modify the SRVPROC member from the SMC sample library as described in the JCL comments and add the procedure to the production PROCLIB.

The following figure provides a sample HTTP server START procedure.

```
//yourprocname  PROC PRM=''
/*
/* Run LOADHOST to initialize the IP environment for
/*      SMC-HTTP IP communications
/*
//stepname EXEC PGM=LOADHOST
//STEPLIB DD DISP=SHR,DSN=your.ncs.smc6200.smclink
//STKHSTDF DD DISP=SHR,DSN=your.host.ip.network.definitions
//STKPRTDF DD DISP=SHR,DSN=your.host.appl.definitions
//STKIFCDF DD DISP=SHR,DSN=your.host.ip.init.definition
//STKIFIDF DD DISP=SHR,DSN=your.host.osa.definition
//STKOWNDF DD DISP=SHR,DSN=your.host.name
//SYSPRINT DD SYSOUT=*
//STDOUT DD SYSOUT=*
//STDERR DD SYSOUT=*
/*
//SERVER EXEC PGM=SKYMAN,REGION=0M,PARM='&PRM',TIME=1440
//STEPLIB DD DISP=SHR,DSN=your.ncs.smc6200.smclink
// DD DISP=SHR,DSN=your.ncs.sos6200.slslink
// DD DISP=SHR,DSN=your.ncs.sws6200.swslink
// DD DISP=SHR,DSN=your.ncs.ssky500.stkload
/*
//SKYPRM DD DISP=SHR,DSN=your.parmlib(SRVPARM)
//SKYSET DD SYSOUT=*
//SKYLOG DD SYSOUT=*
//SKYTRSN DD SYSOUT=*
//STDOUT DD SYSOUT=*
//STDERR DD SYSOUT=*
//SKYDUMP DD SYSOUT=*
//SYSOUT DD SYSOUT=*
//SYSPRINT DD SYSOUT=*
//SYSTEM DD SYSOUT=*
```

FIGURE 12-1 Sample HTTP Server START Procedure

Note – HSC and VTCS load libraries (SLSLINK and SWSLINK) are required in the STEPLIB concatenation to support the ability to route HSC and VTCS commands from a remote SMC to a local HSC TapePlex (using the SMC Route command).

Customizing the HTTP Server Parameter File

The HTTP server START procedure SRVPROC uses the sample parameter file SRVPARM from the SMC sample library. Refer to the following sections for more information and modify the values in SRVPARM for your site's needs.

Note – When using the HTTP server with the SMC, do **not** specify the security *file* or authuserfile *file* HTTP server parameters. These security parameters apply only when using the HTTP server with the VSM GUI. Using these parameters with the SMC causes authentication errors.

Configuration Parameters

gmtoffset *offset*

specifies the system clock offset from GMT. This parameter is required if the system clock is not set to GMT. You can specify the offset in hours, minutes, and seconds. For example, 10 hours 30 minutes specifies ten and a half hours ahead of GMT.

loglevel *level*

specifies the logging message level. Valid values are error, warning and info. The default is warning.

If you specify info, informational, error, and warning messages are logged.
If you specify error, only error messages are logged.

Network Parameters

servername *name*

specifies the server name reported in responses. The default is the network host name.

serverdomain *domain*

specifies the server domain name reported in responses; for example, your company.com. The default is all blanks.

serverbase *hlq*

specifies the high level qualifier of the server data sets in the form *hlq*. For a server used only for SMC communication to HSC, this should be specified as DUMMY. This parameter is required.

port *p*

specifies the IP network port the server listens on for connections. The default is port 80, the standard HTTP port.

CGI Parameters

load modules **SMCGUUI** and **SMCGXTR**

specify the SMC CGI modules to be preloaded for performance.

cgionly **yes**

indicates that the HTTP server instance is used only for communication from SMC to HSC and is not available for VSM GUI functions. The HTTP server's ability to retrieve files or directories is disabled.

requireapf **yes**

overrides the default requirement of apf authorization no (default).

Performance Considerations

The recommended MSP performance group is above batch but below TSO. If the server is extremely busy, reducing the maximum tasks for the HTTP server may improve performance. Use the following parameters to set the initial and maximum number of HTTP server tasks:

startservers **20**

sets initial tasks to 20.

maxclients **20**

sets the maximum number of tasks to 20.

Starting the HTTP Server

To start the HTTP server, enter the following MSP operator command:

```
START SRVPROC
```

The server is active when the following message appears:

```
SKY003I  HTTPD ready to accept requests
```

By default, when the server is started, it uses the SRVPARM member in the SMC sample library.

Stopping the HTTP Server

To stop the HTTP Server, enter either of the following MSP operator commands:

```
P SRVPROC
F SRVPROC,SHUTDOWN
```

Displaying HTTP Server Status

To display the status of the HTTP server, enter the following MSP operator command:

```
F SRVPROC,D S
```

The following shows a display status response:

```
SKY016I  HTTP Server 1.0.0 started at Fri Jan 24 06:51:35 2003
```

```
requests received 85
tasks default: 20 active: 20 limit:40
SKY053I Current active worker tasks: 0
```

This response shows an idle system with the default number of worker tasks, which handle client connections, idle waiting for work. At times of peak demand, the server can dynamically start additional tasks up to the limit.

To display the server connections, enter the following MSP command:

```
F SRVPROC,D C
```

The following shows a display connections response:

```
SKY031I  Connections total: 114 max: 63/min
SKY032I  Connection rates: 0/min 0/hour
SKY026I  Task: 5 Requests: 1 Client: 199.117.186.54 : 36292
```

This response shows one client active whose IP address is 199.117.186.54 and using port 36292.

Note – SMC transactions are displayed as active connections only when the transaction is actively being processed. The SMC HTTP communications model does not establish a persistent connection with the server. Therefore, the D C command will often display no active connections even when several hosts are communicating with the server.

Tracing the SMC in the HTTP Server

SMC requests in the HTTP server carry their trace settings, if any, from the SMC client. If the SMC TRace JOBname CGI command has been entered for a specific job on the client, the trace information for that request is written to the HTTP SKYLOG data set. Do not specify any TRace commands on the SMC client unless requested by StorageTek Software Support.

StorageTek HTTP Server Messages

This section provides information about StorageTek HTTP server messages.

Message Format

Messages are displayed on the console in the following format:

SKYnnnn message-text

where:

- SKY identifies the StorageTek HTTP server.
- *nnnn* is the four-character message number.
- *message-text* is the actual text displayed on the job log or system log.

Message Change Summary

The following messages have been added, changed, or deleted in this release:

New Messages

- SKY068E
- SKY069E
- SKY070E
- SKY071W
- SKY072I
- SKY073E
- SKY074W
- SKY075I

Message Listing

The following HTTP Server messages are listed numerically.

SKY001I

name Server version starting on system running MSP level

Explanation: This is the HTTP server startup message.

SKY002E

Error binding server socket - terminating

Explanation: The server cannot bind to the specified network port. The server shuts down.

SKY003I

name ready to accept requests

Explanation: The server name is ready for normal operation.

SKY004E

Error opening server socket - terminating

Explanation: The server cannot open a socket connection to the required network port. The server shuts down.

SKY005E

Server select failed rc=*ret* err=*msg*

Explanation: An error occurred while listening for a client connection.

SKY006I

TCP/IP connection terminated

Explanation: The client connection was terminated.

SKY007E

Accept error - shutting down

Explanation: There was an error in network connection accept processing. The server shuts down.

SKY008E

Error reading request

Explanation: A network error occurred while reading a client request.

SKY013I

Shutdown command from operator acknowledged

Explanation: The server has received a console command to shut down.

SKY016I

name Server ver started at tttt
"requests received: nnn
"tasks default: dd active: aa limit: ll

Explanation: Response to an operator display status command and indicates the server name, version, start date and the total number of requests received. It also details the worker task settings, the default number of idle tasks, the maximum limit of dynamically started tasks and the current number of active tasks.

SKY018I

Request n task completed rc=ret

Explanation: The worker task *t* has completed with return code *ret*.

SKY023E

Unknown server command: cmd

Explanation: The command *cmd* is not a valid console command.

SKY025E

Invalid command option: oooo

Explanation: The option *oooo* is not a valid option for the operator command.

SKY026I

Task: t Requests: n Client: xxx.xxx.xxx.xxx : pppp

Explanation: This message is issued in response to a display client console command. Task *t* has serviced *n* requests from the client at IP address *xxx.xxx.xxx.xxx* port *pppp*.

SKY027I

No active client connections

Explanation: This message is issued in response to a display client console command, when there are no clients currently connected to the server.

SKY030E

Missing to/from translation string

Explanation: The data set file name translation is incorrect.

SKY031I

Connections total: *nn* max: *mm*/min

Explanation: This message is issued in response to a display client console command. There have been a total of *nn* connections at a maximum rate of *mm* per minute.

SKY031W

Not APF authorized, some facilities not available

Explanation: The HTTP server is not APF authorized.

SKY032I

Connection rates: *nn*/min *mm*/hour

Explanation: This message is issued in response to a display client console command. The connection rates are *nn* per minute and *mm* per hour.

SKY040I

Option *nnnn* *ssss*

Explanation: The parameter option *nnnn* is set to *ssss*.

SKY043E

Terminating execution due to parameter error(s)

Explanation: There was an error in one or more parameters. The server shuts down.

SKY045E

SAF authentication requested but not APF authorized

Explanation: SAF authentication requires caller to be APF authorized, but server is not APF authorized. The server shuts down.

SKY046E

Supplied *parm* is too long

Explanation: The length of the parameter string *parm* exceeds the allowed length.

SKY047E

Unable to open *dsname*

Explanation: The HTTP server was unable to open the data set *dsname* in response to a client request.

SKY048E

abend_message_line

Explanation: Message number for abend reporting messages.

SKY049E

Not APF authorized, cannot continue

Explanation: The server is not APF authorized but APF authorization is required. The server shuts down.

SKY050E

Task shutdown time expired, terminating tasks

Explanation: During HTTP server shutdown, some tasks did not stop before the shutdown timeout was exceeded. These tasks are forcibly terminated.

SKY051E

Cannot find server module *name*

Explanation: When the HTTP server performed its startup checks, it could not find its module: *name*.

SKY052E

Cannot find all server modules, shutting down

The HTTP server could not find all of its modules when it performed its startup checks. The server shuts down.

SKY053I

Current active worker tasks: *t*

Explanation: The current number of worker tasks for servicing requests.

SKY053E

Fatal error in main task, commencing forced shutdown

Explanation: The server suffered a fatal error in its main task and was unable to perform an orderly shutdown.

SKY054E

Fatal error in main task, attempting orderly shutdown

Explanation: The server suffered a fatal error in its main task and is attempting to perform an orderly shutdown.

SKY055I

Forcibly terminating task *t*

Explanation: The task *t* is forcibly terminated.

SKY056I

Disable abend handling option specified, handling disabled

Explanation: The HTTP server abend handlers will not be enabled so any abends can cause dumps and may also shut down the server.

SKY059E

Error initializing translation tables

Explanation: An error occurred while initializing the server file name translation table.

SKY060E

SERVERBASE not set, shutting down

Explanation: The required parameter SERVERBASE was not set in the parameter file. The server shuts down because it cannot locate its data files.

SKY061I

Authentication request received from client at xxx.xxx.xxx.xxx
: pppp

Explanation: A request to authenticate was received from the client at network address xxx.xxx.xxx.xxx and port pppp.

SKY068E

CGI api call error for *function*: *reason*

Explanation: There was an error calling the CGI function *function* for reason *reason*.

SKY069E

Task *nnn* clientConnect: takesocket error: *err reason*

Explanation: The worker task *nnn* encountered an error obtaining the connection socket with error code *err* and error message *reason*.

SKY070E

Passrequest: givesocket error: *err reason*

Explanation: The main task encountered an error passing a connection socket to a worker task, error code *err* and error message *reason*.

SKY071W

Cannot utilize socket implementation *type* errno *err msg*

Explanation: The server cannot use the specified socket implementation *type* because of error code *err* and message *msg*. Server processing continues with the default socket implementation.

SKY072I

Loaded module *module*

Explanation: Module *module* was preloaded as requested by a LOADMODULE parameter.

SKY073E

Connection socket *nn* out of range

Explanation: The connection socket exceeds the supported range of sockets. The connection will be dropped and server operation continues.

SKY074W

Unable to allocate *dsn* Reason: *rr rc=nn code=cc*

Explanation: The data set *dsn* could not be allocated due to reason *rr*, dynamic allocation return code *nn* and code *cc*.

SKY075I

Socket *nnn* settings: *linger=spec sndBuf=sss rcvBuf=rrr*

Explanation: Server connection listener socket *nnn* has the following attributes:

- *linger=spec* is the socket timeout on close, either default or (1, *time-in-seconds*) the socket is unavailable for reuse.

SKY100W

Unable to set socket *option* to *value*

Explanation: The named socket *option* could not be set. Processing continues.

SKY101W

Unable to set socket *option*

Explanation: A socket option could not be set.

SKY102E

Socket *option* error: *explanation*

Explanation: Indicates why a socket option could not be set.

SKY103E

Cannot open parameter file *dsname*, terminating

Explanation: The HTTP server was unable to open the parameter file *dsname*. The server shuts down.

SKY104E

Parameter *ppp* invalid

Explanation: The parameter *ppp* is not known.

SKY105E

Unexpected character *c* encountered, skipping line

Explanation: When parsing the parameter file, an unexpected character was encountered. The parameter is skipped by moving to the next line.

SKY106E

Expected number but non numeric: *ssss*

Explanation: When parsing the parameter file, a non numeric item was found when a number was expected.

SKY107I

parm set to *vvv*

Explanation: The parameter *parm* is set to value *vvv*.

SKY108E

Expected string: *ssss*, skipping

Explanation: When parsing the parameter file, the string *ssss* was expected but not found. Parsing skips to the next parameter.

SKY109I

pppp set to *vvv*

Explanation: When reading the parameter file, the parameter *pppp* was set to value *vvv*.

SKY110E

Unknown token type: *tttt*

Explanation: The parameter token is unknown.

SKY112E

Cannot create *tbl*, terminating

Explanation: During initialization, the memory table *tbl* could not be allocated. The server shuts down.

SKY113E

Cannot start task *tttt*, terminating

Explanation: During initialization, the task *tttt* could not be started. The server shuts down.

SKY114I

Task *tttt* completed, *rc=nn*

Explanation: Task *tttt* completed with return code *nn*.

SKY115I

Commencing server shutdown

Explanation: The server has started to shut down.

SKY116E

Task *tttt* unable to get client id

Explanation: An error occurred while passing a socket connection to the work task *tttt*.

SKY118I

Task *t* waiting for work

Explanation: The worker task *t* is now idle after completing a request.

SKY119I

Task *t* shutting down

Explanation: Task *t* has commenced shutting down.

SKY120E

Task *t* unable to allocate dir list buffer

Explanation: The worker task *t* was unable to allocate a memory buffer needed for a directory listing.

SKY121E

Task *t* unable to open directory readme

Explanation: The worker task *t* encountered an error when attempting to open a directory readme file while listing a directory.

SKY122E

Task *tt* connection error with *xxx.xxx.xxx.xxx* errno *error_text*

Explanation: The worker task *t* encountered a connection error (error number *errno*, text *error_text*) with the client at IP address *xxx.xxx.xxx.xxx*.

SKY123E

Task *t*, connection eof from *xxx.xxx.xxx.xxx*

Explanation: For worker task *t*, the connection to client at IP address *xxx.xxx.xxx.xxx* ended.

SKY124I

Task *t* connection terminated by peer *adr*

Explanation: The network connection to worker task *t* was terminated by the client with IP address *adr*.

SKY125E

Task *t* *cmp*, abend *aaa* caught

Explanation: The abend handler for task *t* in component *cmp*, intercepted a type *aaa* abend. Task *t* is shut down and a replacement task is created.

SKY126E

Task *t* *cmp*, illegal instruction abend caught. Code *aaa*

Explanation: The abend handler for task *t* in component *cmp*, intercepted an illegal instruction abend of type *aaa*. Task *t* will be shut down and a replacement task created.

SKY127E

Task *t* *cmp* memory access abend caught. Code *aaa*

Explanation: The abend handler for task *t* in component *cmp*, intercepted a memory abend of type *aaa*. Task *t* is shut down and a replacement task is created.

SKY128E

Task *t* request error *nnn* msg: *description*

Explanation: For worker task *t*, an HTTP protocol error was encountered for a client request.

SKY129E

ppp out of valid range min - max

Explanation: The numeric parameter *ppp* is outside the allowed range.

SKY130I

hhh handler ready

Explanation: The handler *hhh* task has finished initializing and is ready for work.

SKY131I

hhh handler shutting down

Explanation: The handler *hhh* task has started shutting down.

SKY132E

hhh handler startup timeout, terminating

Explanation: The startup timeout for the handler task *hhh* has been exceeded. The handler will be terminated.

SKY133E

Unable to start *hhh* handler, terminating

Explanation: The HTTP server was unable to start its handler task *hhh*. The server shuts down.

SKY134E

Unable to allocate *mmm* memory, terminating

Explanation: During initialization, memory could not be allocated for *mmm* memory. The server shuts down.

SKY135E

Unable to open log, reason: *rrr*

Explanation: The log handler task was unable to open the log file for reason *rrr*.

SKY136W

Out of memory for stack space, requested *nnnn* bytes

Explanation: An HTTP server task was unable to allocate stack memory.

SKY138W

No free worker tasks, at maximum limit

Explanation: A request has been received but there are no idle worker tasks and the number of tasks is at the maximum limit. A server busy request is returned to the client. If this condition occurs frequently consider increasing the maximum limit of worker tasks to a value where this is a rare occurrence.

Intercepted Messages

Fujitsu Operating System Messages

The messages listed in Table 13 are received by the SMC. Fujitsu message manuals describe the exact format (spacing, etc.) and definition for each message. Ellipses are used to indicate that the message contains more text than is shown.

Correct operation of the SMC depends on these messages. Do not suppress or alter them using products designed to handle messages through the subsystem interface (SSI). Many automated operations systems make use of the subsystem interface to intercept and alter or suppress messages.

Note – If the “suppressed by subsystem” and “hardcopy only” bits are turned on in the WQE (the MSP write queue element) before the SMC has received the message, the SMC ignores the WTO, and the message is not displayed at the console.

If you plan to use an automated operations system and are unsure about how it intercepts messages, contact the product vendor.

Although these messages may be suppressed (that is, prevented from displaying in the console) by using AOF functions, the text of these messages should not be changed. The use of other WTO exits to change the display characteristics or the text of these messages is not supported by the SMC.

Volume serial numbers (‘ser’) as specified in messages from the operating system, are defined as follows:

Messages that contain VOLSERS with more than six characters or any character except A-Z, 0-9, # (crosshatch), \$, ¥ (yen character), and optional trailing blanks are ignored by the SMC.

TABLE A-1 Intercepted Operating System Messages

Message ID	Description
JBB068A	U dddd,ser
JBB111E	D dddd,ser
JBB114E	D dddd...
JBB135A	U dddd,ser...
JBB400A	M dddd, ser...
JBB401A	F dddd,ser...
JBB501A	M dddd,ser{,labtyp}
JBB501E	M dddd,ser{,labtyp}
JBB502E	n,dddd,ser...
JBB509A	F dddd,ser...
JBB512I	I/O ERR LBL ERR SEC VOL...
JBB701D	M dddd, VOLUME TO BE LABELED ser
JBB702I	dddd, VOLUME LABELS CANNOT BE VERIFIED
JBB703I	dddd, VOLUME IS FILE PROTECTED
JDJ233A	M dddd,ser{,labtyp}
JDJ233D	M dddd,ser{,labtyp}
JDJ234E	{K D R} dddd{,ser...}
KHE200I	SWAP dddd to eeee - OPERATOR I/O ERROR
KHE202E	PROCEED WITH SWAP OF dddd TO eeee
KHE203I	ERROR ON dddd, SELECT NEW DEVICE
KHE205I	SWAP ddd - OPERATOR I/O ERROR
KHE207A	WRONG VOLUME MOUNTED ON dddd, MOUNT ser,...
KAA000I	MSP I/O error message processed only for specific Fault Symptom Codes generated by StorageTek tape devices
_TA0233D	Message for ASM2

Tape Management System Messages

CA-1 Messages

The following CA-1 (TMS) messages are intercepted by the SMC. Refer to the appropriate Computer Associates publication for the exact format and meaning of each message.

TABLE A-2 Tape Management System Messages - CA-1

Message ID	Description
CTS001	See CA-1 User Manual, Volume 1
CTS002	See CA-1 User Manual, Volume 1
CTS004	See CA-1 User Manual, Volume 1
CTS005	See CA-1 User Manual, Volume 1
CTS007	See CA-1 User Manual, Volume 1
CTS008	See CA-1 User Manual, Volume 1
CTS009	See CA-1 User Manual, Volume 1
CTS010	See CA-1 User Manual, Volume 1
CTS011	See CA-1 User Manual, Volume 1
CTS014	See CA-1 User Manual, Volume 1
CTS015	See CA-1 User Manual, Volume 1
CTT100A	See CA-1 User Manual, Volume 1
CTT101A	See CA-1 User Manual, Volume 1
CTT102A	See CA-1 User Manual, Volume 1
CTT103A	See CA-1 User Manual, Volume 1
CTT104A	See CA-1 User Manual, Volume 1
CTT105A	See CA-1 User Manual, Volume 1
TMS001	See CA-1 User Manual, Volume 1
TMS002	See CA-1 User Manual, Volume 1
TMS004	See CA-1 User Manual, Volume 1
TMS005	See CA-1 User Manual, Volume 1
TMS007	See CA-1 User Manual, Volume 1
TMS008	See CA-1 User Manual, Volume 1
TMS009	See CA-1 User Manual, Volume 1
TMS010	See CA-1 User Manual, Volume 1
TMS011	See CA-1 User Manual, Volume 1
TMS014	See CA-1 User Manual, Volume 1

TABLE A-2 Tape Management System Messages - CA-1 (Continued)

Message ID	Description
TMS015	See CA-1 User Manual, Volume 1
IECTMS7	See CA-1 User Manual, Volume 1
CA\$F810A	See CA-1 Message Guide
CA\$F813A	See CA-1 Message Guide

CONTROL-M/TAPE (formerly CONTROL-T) Messages

The following CONTROL-M/TAPE messages are intercepted by the SMC. Refer to the appropriate BMC publication for the exact format and meaning of each message.

TABLE A-3 CONTROL-M/TAPE Messages

Message ID	Description
CTT100A	See BMC's INCONTROL for OS/390 and z/OS Message Manual
CTT101A	See BMC's INCONTROL for OS/390 and z/OS Message Manual
CTT102A	See BMC's INCONTROL for OS/390 and z/OS Message Manual
CTT103A	See BMC's INCONTROL for OS/390 and z/OS Message Manual
CTT104A	See BMC's INCONTROL for OS/390 and z/OS Message Manual
CTT105A	See BMC's INCONTROL for OS/390 and z/OS Message Manual

MEDIA, RECTECH, and MODEL Values

This appendix provides values for MEDIA, RECTECH, and MODEL parameters. These parameters are used to specify transport and media characteristics. They are specified in various NCS commands and control statements.

Media Type (MEDIA)

The Media type is used to specify the desired type of media to be used for a data set. It is specified in various NCS commands and control statements, including:

- SMC POLICY operator command
- SMC TAPEREQ control statement
- HSC VOLATTR control statement

The following table describes valid MEDIA types:

Note –

- The SL8500 library supports only the T9840A/B/C/D, T9940B, LTO, SDLT, and T10000A/B/C media types and recording techniques.
- The SL3000 library supports only the T9840C/D, LTO, SDLT, and T10000A/B/C media types and recording techniques.

TABLE B-1 Media Types

Media Type	Description
LONGItud	Indicates standard or enhanced (ECART) capacity cartridges.
ZLONGI	Indicates standard, enhanced (ECART), or extended-enhanced (ZCART) capacity cartridges.
Standard	Indicates a standard capacity cartridge. Synonyms include CST, MEDIA1, STD, 1, 3480. A standard capacity cartridge can be used on any longitudinal transport (i.e., 4480, 4490, 9490, or 9490EE). However, if the data is written on the tape in 36-track, the data cannot be read by an 18-track 4480 transport.
ECART	Indicates an enhanced capacity cartridge. Synonyms include E, ECCST, ETAPE, Long, MEDIA2, 3490E. An ECART cartridge can be used only on 36-track transports (i.e., 4490, 9490, and 9490EE), and is identified by a two tone colored case.

TABLE B-1 Media Types (Continued)

Media Type	Description
ZCART	Indicates an extended-enhanced capacity cartridge. A ZCART cartridge can be used only on TimberLine 9490EE 36-track transports. ZCART can be abbreviated as Z.
Virtual	Indicates a VTV (Virtual Tape Volume) mounted on a VTD (Virtual Tape Drive).
HELical	Indicates a helical cartridge. A helical cartridge can be used only on RedWood transports. The following subtypes and abbreviations specify a helical cartridge: DD3 indicates any DD3A, DD3B, or DD3C helical cartridge. DD3A or A indicates a helical cartridge with a 10GB media capacity. DD3B or B indicates a helical cartridge with a 25GB media capacity. DD3C or C indicates a helical cartridge with a 50GB media capacity. The seventh position in the external label is encoded with the cartridge type (i.e., A, B, or C).
STK1	Indicates any 9840 cartridge.
STK1R	Indicates a 9840 data cartridge. STK1R can be abbreviated as R.
STK1U	Indicates a 9840 cleaning cartridge. STK1U can be abbreviated as U.
STK1Y	Indicates a T9840D cleaning cartridge. STK1Y can be abbreviated to Y.
STK2	Indicates any 9940 cartridge.
STK2P	Indicates a 9940 data cartridge. STK2P can be abbreviated as P.
STK2W	Indicates a 9940 cleaning cartridge. STK2W can be abbreviated as W.
T10000T1	Indicates a full-capacity 500GB T10000A or 1TB T10000B cartridge. T10000T1 can be abbreviated as T1.
T10000TS	Indicates a smaller-capacity 120GB T10000A or 240GB T10000B cartridge. T10000TS can be abbreviated as TS.
T10000CT	Indicates a T10000A or T10000B cleaning cartridge. T10000CT can be abbreviated as CT.
T10000T2	Indicates a full-capacity 5TB T10000C cartridge. T10000T2 can be abbreviated as T2.
T10000TT	Indicates a smaller-capacity 1TB T10000C cartridge. T10000TT can be abbreviated as TT.
T10000CL	Indicates a T10000A, T10000B or T10000C cleaning cartridge. T10000CL can be abbreviated as CL.

Note – T10000C drives can read T10000T1 or T10000TS media but cannot write to that media. T10000C drives can only write to T10000T2 or T10000TT media.

When the MEDia parameter is not specified, a default is chosen based on the value of the RECtech parameter. The following table shows default values used if MEDia is omitted:

TABLE B-2 Media Type Defaults

RECtech Entered	MEDia Default
18track	Standard
36track, 36Atrack, 36Btrack	LONGItud
36Ctrack	ZLONGI
LONGItud	LONGItud
DD3, Helical	DD3A
STK1R, STK1R34, STK1R35 STK1RA, STK1RA34, STK1RA35 STK1RB, STK1RB34, STK1RB35 STK1RAB, STK1RAB34, STK1RAB35 STK1RC, STK1RC34, STK1RC35 STK1RD, STK1RDE, STK1RDN, STK1RD34, STK1RD35, STK1RDE4, STK1RDE5	STK1R
STK2P, STK2P34, STK2P35 STK2PA, STK2PA34, STK2PA35 STK2PB, STK2PB34, STK2PB35	STK2P
T10K, T10KN, T10KE T10KA, T10KAN, T1A34, T1A35, T10KAE, T1AE34, T1AE35 T10KC, T10KCN, T1C34, T1C35, T10KCE, T1CE34, T1CE35	T10000T1*
Virtual	Virtual

* T10000C drives can read T10000T1 or T10000TS media but cannot write to that media. T10000C drives can only write to T10000T2 or T10000TT media.

Recording Technique (RECtech)

The recording technique, or RECtech, is used to specify the method used to record data tracks on the tape surface for the desired data set. It is used in the following NCS commands and control statements:

- SMC POLicy operator command
- SMC TAPEREQ control statement
- SMC UNITAttr operator command
- HSC VOLATTR control statement

The following table describes valid recording techniques:

Note –

- The SL8500 library supports only the T9840A/B/C/D, T9940B, and T10000A/B/C media types and recording techniques.
 - The SL3000 library supports only the T9840C/D and T10000A/B/C media types and recording techniques.
 - The T9940B transport supports both 3490 and 3590 image definitions. However:
 - With VSM, T9940B transports may **only** be defined as 3490-image devices.
 - With a native interface, T9940B transports may **only** be defined as 3590-image devices.
-

TABLE B-3 Recording Techniques

Recording Technique	Description
LONGItud	Indicates any device that records data tracks in a linear format along the length of the tape surface. These devices include 4480, 4490, 9490, and 9490EE transports.
18track	Indicates a 4480 transport.
36track	Indicates a 4490, 9490, or 9490EE transport (any device that records in 36-track mode).
36Atrack	Indicates a 4490 transport.
36Btrack	Indicates a 9490 transport.
36Ctrack	Indicates a 9490EE transport.
HELical	Indicates a device using helical recording.
DD3	Indicates a device using helical recording.
STK1R	Indicates any T9840 transport.
STK1R34	Indicates a 3490E-image T9840 transport.
STK1R35	Indicates a 3590-image T9840 transport.
STK1RA	Indicates a T9840A transport.
STK1RA34	Indicates a 3490E-image T9840A transport.
STK1RA35	Indicates a 3590-image T9840A transport.

TABLE B-3 Recording Techniques (Continued)

Recording Technique	Description
STK1RB	Indicates a T9840B transport.
STK1RB34	Indicates a 3490E-image T9840B transport.
STK1RB35	Indicates a 3590-image T9840B transport.
STK1RAB	Indicates a T9840A or T9840B transport.
STK1RAB4	Indicates a 3490E-image T9840A or T9840B transport.
STK1RAB5	Indicates a 3590-image T9840A or T9840B transport.
STK1RC	Indicates a T9840C transport.
STK1RC34	Indicates a 3490E-image T9840C transport.
STK1RC35	Indicates a 3590-image T9840C transport.
STK1RD	Indicates any T9840D transport.
STK1RDE	Indicates an encryption-enabled 3490E- or 3590-image T9840D transport.
STK1RDN	Indicates a non-encryption-enabled 3490E- or 3590-image T9840D transport.
STK1RD34	Indicates a non-encryption-enabled 3490E-image T9840D transport.
STK1RD35	Indicates a non-encryption-enabled 3590-image T9840D transport.
STK1RDE4	Indicates an encryption-enabled 3490E-image T9840D transport.
STK1RDE5	Indicates an encryption-enabled 3590-image T9840D transport.
STK2P	Indicates any T9940 transport.
STK2P34	Indicates a 3490E-image T9940 transport.
STK2P35	Indicates a 3590-image T9940 transport.
STK2PA	Indicates a T9940A transport.
STK2PA34	Indicates a 3490E-image T9940A transport.
STK2PA35	Indicates a 3590-image T9940A transport.
STK2PB	Indicates a T9940B transport.
STK2PB34	Indicates a 3490E-image T9940B transport.
STK2PB35	Indicates a 3590-image T9940B transport.
T10K	Indicates all T10000 transports.
T10KN	Indicates all non-encrypted T10000 transports.
T10KE	Indicates all encrypted T10000 transports.
T10KA	Indicates any T10000A transport.
T10KAN	Indicates a non-encryption enabled 3490E- or 3590-image T10000A transport.
T1A34	Indicates a non-encryption enabled 3490E-image T10000A transport.
T1A35	Indicates a non-encryption enabled 3590-image T10000A transport.

TABLE B-3 Recording Techniques (Continued)

Recording Technique	Description
T10KAE	Indicates an encryption-enabled 3490E- or 3590-image T10000A transport.
T1AE34	Indicates an encryption-enabled 3490E-image T10000A transport.
T1AE35	Indicates an encryption-enabled 3590-image T10000A transport.
T10KB	Indicates any T10000B transport.
T10KBN	Indicates a non-encryption enabled 3490E- or 3590-image T10000B transport.
T1B34	Indicates a non-encryption enabled 3490E-image T10000B transport.
T1B35	Indicates a non-encryption enabled 3590-image T10000B transport.
T10KBE	Indicates an encryption-enabled 3490E- or 3590-image T10000B transport.
T1BE34	Indicates an encryption-enabled 3490E-image T10000B transport.
T1BE35	Indicates an encryption-enabled 3590-image T10000B transport.
T10KC	Indicates any T10000C transport.
T10KCN	Indicates a non-encrypted 3490E- or 3590-image T10000C transport.
T1C34	Indicates a non-encrypted 3490E-image T10000C transport.
T1C35	Indicates a non-encrypted 3590-image T10000C transport.
T10KCE	Indicates an encryption-enabled 3490E- or 3590-image T10000C transport.
T1CE34	Indicates an encryption-enabled 3490E-image T10000C transport.
T1CE35	Indicates an encryption-enabled 3590-image T10000C transport.
Virtual	Indicates a VTV (Virtual Tape Volume) mounted on a VTD (Virtual Tape Drive).

When the RECtech parameter is not specified, a default is chosen based on the value of the MEDIA parameter. The following table shows default values used if RECtech is omitted.

TABLE B-4 Recording Technique Defaults

MEDIA Entered	RECtech Default
LONGItud	LONGItud
ZLONGI	LONGitude
Standard	LONGItud
ECART	36track
ZCART	36Ctrack
DD3A, DD3B, DD3C, DD3D	DD3
STKR, STK1U, STKY	STK1R
STK2P, STK2W	STK2P
T1000T1, T1000TS, T1000CL	T10K
T1000CT	T10KA + T10KB
T1000T2, T1000TT	T10KC
Virtual	Virtual

MODeL Type (MODeL)

The model type is used to specify the model number of a transport (drive), or drive. MODeL provides the same type of information as RECtech, but a user may find it more convenient to specify a transport model rather than a recording technique. MODeL and RECtech are mutually exclusive.

MODeL is used in the following NCS commands and control statements:

- SMC POLIcy operator command
- SMC TAPEREQ control statement
- SMC UNITAttr operator command
- HSC VOLATTR control statement

The following table describes valid MODeL types:

Note –

- The SL8500 library supports **only** model types associated with T9840, T9940, and T10000 series transports.
- The SL3000 library supports **only** model types associated with the T9840C, T9840D, and T10000 series transports.
- You can specify multiple values for this parameter; separate each value with a comma.

TABLE B-5 Model Types

Model Type	Description
4480	Indicates a 4480 (18-track) transport.
4490	Indicates a 4490 (36-track Silverton) transport.
9490	Indicates a 9490 (36-track Timberline) transport.
9490EE	Indicates a 9490EE (36-track Timberline EE) transport.
SD3	Indicates an SD-3 (RedWood) transport.
9840	Indicates a 3490E-image T9840A transport.
984035	Indicates a 3590-image T9840A transport.
T9840B	Indicates a 3490E-image T9840B transport.
T9840B35	Indicates a 3590-image T9840B transport.
T9840C	Indicates a 3490E-image T9840C transport.
T9840C35	Indicates a 3590-image T9840C transport.
T9840D	Indicates a non encryption-enabled 3490E-image T9840D transport.
T9840D35	Indicates a non encryption-enabled 3590E-image T9840D transport.
T9840DE	Indicates an encryption-enabled 3490E-image T9840D transport.
T9840DE5	Indicates an encryption-enabled 3590E-image T9840D transport.
T9940A	Indicates a 3490E-image T9940A transport.
T9940A35	Indicates a 3590-image T9940A transport.

TABLE B-5 Model Types (Continued)

Model Type	Description
T9940B	Indicates a 3490E-image T9940B transport.
T9940B35	Indicates a 3590-image T9940B transport.
T1A34	indicates a non-encryption enabled 3490E-image T10000A transport.
T1A35	Indicates a non-encryption enabled 3590-image T10000A transport.
T1AE34	Indicates an encryption-enabled 3490E-image T10000A transport.
T1AE35	Indicates an encryption-enabled 3590-image T10000A transport.
T1B34	Indicates a non-encryption enabled 3490E-image T10000B transport.
T1B35	Indicates a non-encryption enabled 3590E-image T10000B transport.
T1BE34	Indicates an encryption-enabled 3490E-image T10000B transport.
T1BE35	Indicates an encryption-enabled 3590-image T10000B transport.
T1C34	indicates a non-encryption enabled 3490E-image T10000C transport.
T1C35	Indicates a non-encryption enabled 3590-image T10000C transport.
T1CE34	Indicates an encryption-enabled 3490E-image T10000C transport.
T1CE35	Indicates an encryption-enabled 3590-image T10000C transport.
Virtual	Indicates a VTV (Virtual Tape Volume) mounted on a VTD (Virtual Tape Drive).

TAPEREQ Conversion Script (POLCVT02)

Overview

POLCVT02 is a REXX script designed to assist in converting existing TAPEREQ statements to use the new SMC POLICY method. This script is included in the SMC SAMPLIB. The sample JCL file POLCVT01 is used to execute the script.

The script reads existing TAPEREQ statements and produces the following output:

- TAPEREQ statements with existing policy parameters (MEDIA, RECTECH, etc.) replaced by a new POLICY name parameter
- POLICY definitions derived from the original TAPEREQ definitions. Policy names are created using the format POL*nnnnnn*, where *nnnnnn* is a decimal number from 00001 to 99999.

Note –

- The conversion script assumes that each TAPEREQ definition identifies a unique set of policy definitions. If multiple TAPEREQ definitions are used to identify policy, do not rely on the output of this conversion script to replace TAPEREQ processing. The output POLICY data set may require additional modifications.
- The TAPEREQ default VOLTYPE value is * (all volume types), your generated POLICY output file may contain policies with a VOLTYPE of SPECIFIC when the policy should reference scratch only.

If this occurs, remove the VOLTYPE(SPECIFIC) POLICY statements from the output file. Note that in normal circumstances it is not necessary to provide any policies for specific allocations, since the SMC obtains information from the TapePlex about media and location that is used by default.

Executing the Script

Perform the following steps to execute the TAPEREQ conversion script:

1. Copy the SAMPLIB member POLCVT01 to your JCL library.
POLCVT01 contains sample JCL to execute the POLCVT02 REXX script as follows:

```
//POLCVT01 JOB (ACCTINFO), 'CONVERT TAPEREQS TO USE POLICY'
/*----- */
/* Modify this JCL to convert TAPEREQ definitions to use */
/* policy definitions provided through the POLICY command. */
/* This JCL executes a REXX samplib program called POLCVT02. */
/* Change the following DD statements to identify the */
/* - dataset that contains the POLCVT02 REXX program */
/* - dataset that contains the TAPEREQ input statements */
/* - dataset that will contain the TAPEREQ output */
/* - dataset that will contain the POLICY output */
/*----- */
//STEP1 EXEC PGM=IKJEFT01
//SYSEXEC DD DISP=SHR,DSN=rexx.dataset
//INTAPREQ DD DISP=SHR,DSN=tapereq.input(member)
//OTTAPREQ DD DISP=OLD,DSN=tapereq.output(member)
//OTPOLICY DD DISP=OLD,DSN=policy.output(member)
/*NPOLICY DD DISP=SHR,DSN=policy.input(member)
//SYSTSPRT DD SYSOUT=*
//SYSTSIN DD *
    %POLCVT02 INTAPREQ OTTAPREQ OTPOLICY ( TRACE 0 )
/*
```

2. Change the JOB card to reflect your environment.
3. Change the SYSEXEC DD to point to the REXX data set program, POLCVT02.
4. Change the INTAPREQ DD statement to identify the data set containing your input TAPEREQ definitions.
5. Change the OTTAPREQ DD statement to identify the destination data set for the output TAPEREQ definitions.
6. Change the OTPOLICY DD statement to identify the destination data set for the output POLICY definitions.
7. Optionally, uncomment and change the INPOLICY DD statement to identify the data set containing input POLICY definitions. This data set contains previously defined POLICY statements, or those that exist from a previous execution of the conversion script.
8. Review the generated output to ensure that each output POLICY statement contains all policies, and delete any unnecessary policies with VOLTYPE (SPECIFIC).
Optionally, edit both the OTTAPREQ and output POLICY files to assign meaningful names to the policies.

SMC Compatibility Matrix

Use the following matrix to determine SMC compatibility with HSC and the StorageTek HTTP Server:

TABLE D-1 SMC Compatibility Matrix

	Compatible HSC Releases	Compatible HTTP Server Releases
SMC 6.2	6.1, 6.2	6.1, 6.2
SMC 6.1	6.1, 6.2	6.1, 6.2

SMC Interaction with Other Software

Automated Operations

Customers who use an automated operations product should review WTOR SMC0110, issued during SMC swap processing, for possible auto-ops rule changes.

Open Type J

The Open Type J macro is **not** supported during SMC message handling processing.

Additionally, SMC allocation enhancements may not operate if you use the MSP Open Type J macro. Because this macro allows you to change volume serial numbers or data set names at open time, information available at Job Step Allocation time may be incorrect as interpreted by the SMC.

Note – Some vendor software products use MSP Open Type J. If you are experiencing unexpected allocation results using a vendor software product, check with the vendor to determine if Open Type J is used and follow the recommendations below.

SMC allocation may influence MSP allocation erroneously based on information that may have changed at open time. To prevent this problem when using the Open Type J macro, specify the appropriate esoteric in the JCL or specify an appropriate esoteric in an applicable TAPEREQ control statement **or POLICY command**.

SAMS: DISK (DMS)

Sterling Software's SAMS: DISK (DMS) has two methods of allocating transports:

- Allocates transports at session startup, holds onto the transports throughout the session and uses Open Type J (see page [299](#))
- Uses dynamic allocation (DYNALLOC) to allocate transports when required

The SMC allocates correctly when dynamic allocation is used. Therefore, the latter method of allocating transports is recommended.

MSP Security Packages

Ensure that your MSP security package (e.g., RACF, TopSecret) is configured to grant SMC the necessary authority to respond to MSP swap messages.

Glossary

Terms are defined as they are used in the text. If you cannot find a term here, check the index.

A

Abnormal end of task (abend) A software or hardware problem that terminates a computer processing task.

ACS-id A method used in the LIBGEN process to identify ACSs by using hexadecimal digits, 00 to nn.

ACS *See* Automated Cartridge System.

ACS library A library is composed of one or more Automated Cartridge Systems (ACSs), attached cartridge drives, and cartridges residing in the ACSs.

address Coded representation of hardware id, or the destination or origination of data.

allocation The assignment of resources to a specific task.

asynchronous transmission Character-oriented data transmission (as distinct from Fujitsu's block-mode transmission).

Automated Cartridge System (ACS) A fully-automated, cartridge storage and retrieval library subsystem consisting of one or more Library Storage Modules (LSMs) connected by pass-thru ports.

Automated Cartridge System Library Software (ACSL) The library control software, which runs in the UNIX®-based Library Control System.

automatic mode A relationship between an LSM and all attached hosts. LSMs operating in automatic mode handle cartridges without operator intervention. This is the normal operating mode of an LSM that has been modified online. The opposite situation is "manual mode." *See* manual mode.

B

bar code A code consisting of a series of bars of varying widths. This code appears on the external label attached to the spine of a cartridge and is equivalent to the volume serial number (volser). This code is read by the robot's machine vision system.

BISYNC Binary Synchronous Communications. An early low-level protocol developed by Fujitsu and used to transmit data on a synchronous communications link. It is a form of data transmission in which synchronization of characters is controlled by timing signals generated at the sending and receiving stations.

C

CAPid A CAPid uniquely defines the location of a CAP by the LSM on which it resides. A CAPid is of the form "AAL" where "AA" is the acs-id and "L" is the LSM number.

cartridge The plastic housing around the tape. It is approximately 4 inches (100 mm) by 5 inches (125 mm) by 1 inch (25 mm). The tape is threaded automatically when loaded in a transport. A plastic leader block is attached to the tape for automatic threading. The spine of the cartridge contains an OCR/Bar Code label listing the VOLSER (tape volume identifier).

Cartridge Access Port (CAP) An assembly that allows several cartridges to be inserted into or ejected from an LSM without human entry into the LSM.

cartridge drive (CD) A hardware device containing two or four cartridge transports and associated power and pneumatic supplies.

cartridge tape I/O driver Operating system software that issues commands (for example, read, write, and rewind) to cartridge subsystems. It is the software focal point for attaching a particular type of control unit. (An example is Oracle's StorageTek CARTLIB product.)

cartridge transport *See* transport.

cell A receptacle in the LSM in which a single cartridge is stored.

CGI Common Gateway Interface

channel A device that connects the host and main storage with the input and output devices' control units. A full-duplex channel has two paths (that is, 2 wires, or one wire with signals at two frequencies). A half-duplex channel requires that one port receives while the other transmits.

channel-to-channel (CTC) Refers to the communication (transfer of data) between programs on opposite sides of a channel-to-channel adapter.(I)

client The ultimate user of the ACS services as provided by the Library Control System.

client link The communications link between the LCS and a client.

client-server A model of interaction in a distributed system in which a program at one site serves a request to a program at another site and awaits a response. The requesting program is called a client; the program satisfying the request is called a server.

client system The system to which the LCS provides an interface to a StorageTek Automated Cartridge System.

Client System Component (CSC) Software that provides an interface between the Client Computing System's operating system and the StorageTek Library Control System (LCS).

coaxial cable A transmission medium used in data transmissions for networks using synchronous communications, as opposed to twisted-pair, the primary medium for asynchronous RS-232 communications.

complex A system composed of other systems, specifically the ACS server system and the client system.

connected mode A relationship between a host and an ACS. In this mode, the host and an ACS are capable of communicating (in the sense that at least one station to this ACS is online).

connection number The unique identifier on the server for a communications path. The number is assigned by TCP/IP to identify the unique connection between the server node and a specific port on the server, and the client node and a specific port on the client. The connection number exists only as long as the connection exists.

console The primary I/O device to control a session on a system.

control data set (CDS) The data set used by the host software to control the functions of the automated library. Also called a library database.

Control Path Adaptor (CPA) A Bus-Tech, Inc. hardware device that allows communications between a host processor's block multiplexer channel and a local area network.

Control Unit (CU) A microprocessor-based unit situated locally between a channel and an I/O device. It translates channel commands into device commands and sends device status to the channel.

coupling facility A special logical partition that provides high-speed caching, list processing, and locking functions in a sysplex.(I)

coupling facility channel A high bandwidth fiber optic channel that provides the high-speed connectivity required for data sharing between a coupling facility and the central processor complexes directly attached to it.(I)

coupling services In a sysplex, the functions of XCF that transfer data and status between members of a group residing on one or more MSP systems in the sysplex.(I)

cross-system coupling facility (XCF) XCF is a component of MSP that provides functions to support cooperation between authorized programs running within a sysplex.(I)

CTC Channel-to-channel.

Data Path Adapter A hardware device which translates from a client computing system's data protocol to the data protocol of the StorageTek Control Unit or IMU. An example is DEC's TC44-AA/BA STI-to-4400 ACS Interconnect.

D

data set A set of records treated as a unit.

data sharing The ability of concurrent subsystems or application programs to directly access and change the same data while maintaining data integrity.(I)

device number A four-digit hexadecimal number that uniquely identifies a device attached to a processor.

device preferencing The process of preferring one 36-track transport type over another 36-track transport type.

device separation *See* drive exclusion.

DFSMS Data Facility Storage Management Subsystem.

direct access storage device (DASD) Fujitsu's term for a disk drive storage device.

directed allocation *See* drive prioritization.

disconnected mode A relationship between a host and an ACS. In this mode, the host and the ACS are not capable of communicating (there are no online stations to this ACS).

dotted-decimal notation The syntactic representation of a 32-bit integer that consists of four 8-bit numbers written in base ten with periods (dots) separating them. In TCP/IP descriptions, dotted-decimal notation is used for Internet addresses.

drive exclusion (previously referred to as *device separation*) refers to the Storage Management Component (SMC) function of excluding drives for an allocation request based on SMC exclusion criteria.

drive panel An LSM wall containing tape transports. The drive panel for a T9840 transport can contain either 10 or 20 transports. The drive panel for a non-T9840 transport can contain a maximum of 4 transports.

drive prioritization (previously referred to as *directed allocation*) refers to the Storage Management Component (SMC) function of influencing selection of a particular drive based on allocation criteria, including volume location.

Dual LMU A hardware/microcode feature that provides a redundant LMU capability.

dump A printed representation of the contents of main storage at time *t*. This representation is used for debugging purposes.

dynamic server switching The capability of switching server processors when a system failure occurs on the active server.

E

ECART Enhanced Capacity Cartridge.

Enhanced Capacity Cartridge A cartridge that has a length of 1100 feet and can be used only on 36-track transports (i.e., 4490, 9490, and 9490EE).

Enterprise Systems Connection (ESCON) A set of products and services that provides a dynamically connected environment using optical cables as a transmission medium.(I)

error codes (EC) Numeric codes displayed by messages indicating the type of problem that caused an error.

error recovery procedures (ERP) Procedures designed to help isolate and, where possible, to recover from errors in equipment.

ESCON Enterprise Systems Connection.

esoteric name The name assigned to transports that have the same device type.

Ethernet One LAN architecture using a bus topology that allows a variety of computers to be connected to a common shielded coaxial spine. The Ethernet architecture is similar to the IEEE 802.3 standard.

event control block (ECB) Provides an area for a completion code to be stored when an operation has completed.

F

file A set of related records treated as a unit.

File Transfer Protocol (FTP) A TCP/IP command that provides a way to transfer files between machines connected through TCP/IP.

foreign socket One of two end-points in a TCP/IP connection-oriented protocol. Specifies the address of a foreign host that can connect to the server.

G

GB 1,073,741,834 bytes of storage

H

handshake A flow-of-control signal sent by one process to another.

helical cartridge A high capacity, helical scan cartridge that can hold up to 50GB of uncompressed data. This cartridge can be used only on RedWood (SD-3) transports.

host computer A computer that controls a network of computers.

Host Software Component (HSC) Software running on the Library Control System processor that controls the functions of the ACS.

Host Software Component utilities Utilities provided by the VM/HSC that can be executed from the HSCUTIL virtual machine. *See* client-initiated utilities.

HSC *See* Host Software Component.

HTTP Hypertext Transfer Protocol.

I

IEEE 802.3 A standard produced by the IEEE and accepted worldwide for local area networks using CSMA/CD (Carrier Sense Multiple Access with Collision Detection).

ICRC Improved Cartridge Recording Capacity. A compression and compaction feature that increases the amount of data that can be stored on a 1/2-inch cartridge.

initial program load (IPL) A process that activates a machine reset.

Internet A collection of networks using TCP/IP that functions as a virtual network.

Internet address The numbering system used to specify a network or host on that network for TCP/IP communications. Standard Internet address notation is dotted-decimal format.

Internet Protocol (IP) Formal description of messages and rules two networks use to exchange messages.

ISMF Interactive Storage Management Facility.

J

job control language (JCL) A problem oriented language designed to describe a job's processing requirements to an operating system.

JES Job entry subsystem.(I)

L

LAN *See* local area network.

LCS *See* Library Control System.

LCS processor console The Library Control System processor console is used to control the VM operating system (for the VM-based LCS).

LCU *See* Library Control Unit.

LIBGEN The process of defining the configuration of a library to the VM/HSC.

library *See* TapePlex.

library cartridge transport *See* transport.

library complex A library complex consists of one HSC Control Data Set (CDS) and may contain up to 256 Automatic Cartridge Systems (ACSs), each of which may contain up to 24 Library Storage Modules (LSMs).

library control component Software that controls the mounting and dismounting of cartridges in an ACS.

library control platform The hardware and software that provides the proper environment for the Library Control System.

library control processor Properly configured computer hardware that supports the operation of the Library Control System.

Library Control Software A library control component, the client system interface, and library utilities.

Library Control System (LCS) The library control platform and the Library Control Software.

Library Control Unit (LCU) The portion of an LSM that controls the movements of the robot.

library database A file or data set containing information about the location and status of the removable media volumes, such as cell location, scratch status. Also called a control data set (CDS).

library drive A cartridge drive in the ACS, as distinct from a stand-alone cartridge drive.

Library Management Unit (LMU) A hardware and software product that coordinates the activities of one or more LSMs/LCUs.

library mode The operation of a 4480 Cartridge Subsystem as part of a 4400 Automated Cartridge System, as opposed to manual mode, in which the operator inserts cartridges into the transports. *See* manual mode.

Library Storage Module (LSM) The standard LSM (4410) a twelve-sided structure with storage space for up to around 6000 cartridges. It also contains a free-standing, vision-assisted robot that moves the cartridges between their storage cells and attached transports. *See* also PowderHorn, StreamLine SL8500, and WolfCreek.

LMU *See* Library Management Unit.

local area network (LAN) A network in a small (local) geographic area.

local port The designation of a given application or process among many that are available for a TCP/IP-capable host processor.

local socket The address combination of a TCP/IP-capable host's network address and a specific port for an application process.

logical port (LP) CLS software that interfaces with the client system. The CLSLP is one of the software components used to pass data between the client system and the VM/HSC.

LP *See* logical port.

LSM *See* Library Storage Module.

LSM-id An LSM-id is composed of the ACS-id joined to (concatenated with) the LSM number.

LSM number A method used to identify an LSM. An LSM number is the result of defining the SLIACS macro LSM parameter during a LIBGEN. The first LSM listed in this parameter acquires the LSM number of 00 (hexadecimal) the second LSM listed acquires a number of 01, and so forth, until all LSMs are identified (up to a maximum of 24 or hexadecimal 17).

M

manual mode Operation of a cartridge drive apart from an ACS. *See* library mode.

master LMU The LMU currently controlling the functional work of the ACS in a dual LMU configuration.

mixed configuration A configuration that contains different types of cartridge drives in both manual and library modes.

modem A device that enables digital data to be transmitted over an analog transmission facility.

multi-client The environment where more than one (homogenous or heterogeneous) client system is connected to one LCS.

N

NCS Nearline Control Solution, consisting of SMC, HSC, and the StorageTek HTTP server.

O

OCR label Optical character recognition label. An external label attached to the spine of a cartridge that is both human and machine readable.

operator console In this document, the operator console refers to the MSP client system console.

operating system (OS) Software that controls the execution of programs that facilitate overall system operation.

P

Pass-thru Port (PTP) A mechanism that allows a cartridge to be passed from one LSM to another in a multiple LSM ACS.

physical port The communications hardware required to support a server/client link.

physical volume A physically bound unit of data file media. *See* cartridge.

PowderHorn (9310) The high-performance version of the standard LSM.

pre-configured package A storage server package including all hardware, software, and configuration parameter settings delivered by the vendor.

product change request (PCR) A request for enhancement to a product. Normally, this request comes from a client, but may come from Oracle.

program temporary fix (PTF) A software release designed to remedy one or a series of defects.

protocol A formal description of message formats and the rules two or more machines must follow to exchange these messages.

R

recovery Automatic or manual procedures to resolve problems in the server system.

reel-id Identifier of a specific tape volume. Equivalent to volume serial number (VOLSER).

request Term used to refer to commands issued to the 4400 ACS to perform a tape-related function.

S

scratch tape A tape that is available to any user because it is not owned.

scratch tape subpool A defined subset of all scratch tapes. Subpools are composed of one or more ranges of volumes with similar physical characteristics (type of volume—reel or cartridge, reel size, length, physical location, and so on). Some installations may also subdivide their scratch pools by other characteristics such as label type.

SD-3 The StorageTek helical cartridge transport. Also known as RedWood.

server An NCS library control system such as HSC. In SMC a server is represented by a named SERVER path to a named TAPEPLEX. While the StorageTek HTTP server software component is required as the middle ware on the remote host, the server, as far as SMC is concerned is the NCS library control system operating on the remote host.

socket A unique address on a network plus a node address plus the id of one specific application on a specific network. An abstraction used by TCP/IP.

standard capacity cartridge A cartridge that can be used on any longitudinal transport (i.e., 4480, 4490, 9490, or 9490EE).

standby The status of a station that has been varied online but is connected to the standby LMU of a dual LMU ACS.

standby LMU The redundant LMU in a dual LMU configuration that is ready to take over in case of a Master LMU failure or when the operator issues a SWITCH command.

station A hardware path between the host computer and an LMU over which the VM/HSC and LMU send control information.

Storage Management Component (SMC) Software interface between Fujitsu's MSP operating systems and StorageTek real and virtual tape hardware. SMC performs the allocation processing, message handling, and SMS processing for the NCS solution.

storage server A set of hardware and software products designed to enable heterogeneous computer systems to use automated tape cartridge library services.

switchover The assumption of master LMU function by the standby LMU.

synchronous *See* BISYNC.

synchronous LAN Local area network built on synchronous communications.

sysplex A set of MSP systems communicating and cooperating with each other through certain multisystem hardware components and software services to process customer workloads.(I)

Systems Network Architecture (SNA) A description of the logical structure, formats, protocols, and operational sequences for transmitting information units through and controlling the configuration and operation of networks.

T

tape drive A tape processing device consisting of up to four transports in a cabinet. A drive can refer to an individual transport.

tape library management system (TLMS) TLMS, as used in this document, refers to any tape library management system, not to CA-1.

TapePlex (formerly “library”), a single StorageTek hardware configuration, normally represented by a single HSC Control Data Set (CDS). A TapePlex may contain multiple Automated Cartridge Systems (ACSs) and Virtual Tape Storage Subsystems (VTSSs).

TCP/IP Transmission Control Protocol/Internet Protocol.

trace event type Types of event traced through the system when tracing is enabled.

trace file A file that contains information useful for debugging the system.

transaction A specific set of input that triggers the execution of a specific process.

Transmission Control Protocol (TCP) An inter-network standard protocol that provides a full-duplex stream service.

transport An electro-mechanical device used to thread, position, and read or write from a tape.

U

UCB Unit Control Block.

userid Sometimes referred to as the VM userid, the userid is the name that identifies a specific “virtual machine” user or client.

utility Program that performs a function ancillary to the chief function(s) of a computer system.

V

virtual machine (VM) A functional simulation of a computer and its associated devices. Each virtual machine is controlled by a suitable operating system.

virtual storage A feature of the OS where main storage requirements are allocated by segments (or pages) as needed by programs, thus creating the apparent existence of unlimited or virtual storage.

Virtual Storage Manager (VSM) A storage solution that virtualizes volumes and transports in a VTSS buffer in order to improve media and transport use.

Virtual Tape Control System (VTCS) The primary host code for the Virtual Storage Manager (VSM) solution. This code operates in a separate address space, but communicates closely with HSC.

Virtual Tape Storage Subsystem (VTSS) The DASD buffer containing virtual volumes (VTVs) and virtual drives (VTDs). The VTSS is a StorageTek RAID 6 hardware device with microcode that enables transport emulation. The RAID device can read and write "tape" data from/to disk, and can read and write the data from/to a real tape drive (RTD).

Virtual Telecommunications Access Method (VTAM) IBM host-resident communications software that serves as a common interface for communications.

volume A tape cartridge (data carrier) that is mounted or dismounted as a unit.

volume serial number (VOLSER) An identifier of a physical volume.

W

WolfCreek (9360) The high-performance LSM with a smaller capacity than the standard LSM.

X

XCF Cross-system coupling facility.

Z

ZCART An extended-enhanced cartridge that uses a thinner media to provide twice the capacity of the enhanced capacity (ECART) cartridge. This cartridge has a length of 2200 feet and can be used only on TimberLine 9490EE 36-track transports.

Numerics

802.3 See IEEE 802.3.

3270 IBM synchronous, block-mode, half-duplex terminals preferred for use with IBM 370 and related types of machine.

3270 protocol A telecommunications protocol that supports networks of 327x CRTs on IBM mainframes.

3274 Terminal control unit used on the ACS for processor-to-LMU communications.

3480 IBM's 18-track half-inch cartridge tape drive model.

3490 IBM's 36-track half-inch cartridge tape drive model.

3590 IBM's newest cartridge tape drive model that supports 128-track recording technique.

4400 Automated Cartridge System (ACS) A fully automated, cartridge-based, 18-track storage and retrieval library. A 4400 ACS consists of 1 to 256 LMUs with each LMU connected to from 1 to 24 LSMs.

4410 The standard Library Storage Module (LSM).

4411 Library Control Unit (LCU).

4480 The StorageTek 18-track 1/2-inch cartridge transport.

4480 Cartridge Subsystem The StorageTek 4480 Cartridge Subsystem consists of a control unit (CU) plus cartridge drives (CDs).

4490 The StorageTek 36-track long-tape cartridge transport with ESCON support. Also known as Silverton.

4780 Same as a 4480, but is used for attachment to certain non-IBM computers.

8380 The StorageTek DASD system.

9310 The PowderHorn, a high-performance version of the standard LSM (4410)

9360 The WolfCreek, a high-performance LSM with a smaller capacity than the standard LSM (4410).

9490 The StorageTek 36-track cartridge transport. Also known as TimberLine.

9490EE The StorageTek 36-track cartridge transport. Also known as TimberLine EE.

9740 A small, four-sided StorageTek library that supports large-style cartridge transports. This library can be configured to contain either 326 cartridges or 494 cartridges.

SL3000 The StorageTek high performance library scalable from 200 to 3,000 cartridge slots.

SL8500 The StorageTek high performance library scalable from 29 terabytes to 70 petabytes with up to 70,000 tape slots.

T9840A The StorageTek access-centric cartridge transport capable of reading and writing 9840A cartridges.

T9840B The StorageTek access-centric cartridge transport capable of reading and writing T9840B cartridges.

T9840C The StorageTek access-centric cartridge transport capable of reading and writing T9840C cartridges.

T9840D The StorageTek access-centric cartridge transport capable of reading and writing T9840D cartridges.

T9940A The StorageTek capacity-centric cartridge transport capable of reading and writing 60GB T9940A cartridges.

T9940B The StorageTek capacity-centric cartridge transport capable of reading and writing 200GB T9940B cartridges.

T10000A The StorageTek high-capacity cartridge transport capable of reading and writing 120GB or 500GB T10000A cartridges.

T10000B The StorageTek high-capacity cartridge transport capable of reading and writing 240GB or 1TB T10000B cartridges.

T10000C The StorageTek high-capacity cartridge transport capable of reading and writing 1TB or 5TB T10000C cartridges.

Index

A

- affinity separation, 73
- allocation
 - JES2, 76
- ALLOCDef command, 87
- ALLOCJob command, 92

C

- CA-1 (TMS) messages, 283
- client communication monitor subtask, 32
- CMDDef command, 96
- command prefix, SMC, 85
- commands
 - issuing, 84
 - ALLOCDef, 87
 - ALLOCJob, 92
 - CMDDef, 96
 - COMMtest, 98
 - Display Drive, 101
 - Display Volume, 104
 - DRIVemap, 106
 - LIBrary, 108
 - LlSt, 109
 - LOG, 111
 - MOUNTDef, 114
 - MSGDef, 117
 - MSGJob, 120
 - POLicy, 123
 - READ, 130
 - RESYNChronize, 132
 - Route, 134
 - SERVer, 137
 - STORMNGR, 142
 - TAPEPlex, 144
 - TCPip, 161
 - TRace, 164
 - TREQDef, 169
 - UEXit, 171
 - UNITAttr, 174, 175
 - USERMsg, 177
- COMMtest command, 98
- configuration scenarios

- SMC and a single HSC TapePlex (local), 34
- SMC and a single HSC TapePlex (remote), 36
- SMC and a single HSC TapePlex with multiple remote server paths, 40
- SMC and a single HSC TapePlex with one local and one remote path, 38
- SMC with two TapePlexes, 42, 44
- control statement, TAPEREQ, 149
- conventions
 - control statements, 23
 - syntax flow diagrams, 19
 - typographic, 19

D

- deferring mounts, 75
- description, SMC, 29
- device preferencing, 157
- DFSMSrmm messages, 284
- Display Drive command, 101
- Display Volume command, 104
- drive exclusion
 - overview, 66
 - scratch request, 70
 - specific request, 68
 - virtual scratch request, 72
- drive prioritization, 74
- DRIVemap command, 106

E

- examples
 - ALLOCDef command, 91
 - ALLOCJob command, 95
 - CMDDef command, 97
 - COMMtest command, 100
 - Display DRive command, 103
 - Display Volume command, 105
 - DRIVemap command, 107
 - LlSt command, 110
 - LOG command, 113
 - MOUNTDef command, 116
 - MSGDef command, 119
 - MSGJob command, 122

- POLicy command, 129
- READ command, 131
- Route command, 135
- SERVer command, 141
- TAPEPlex command, 148
- TAPEREQ control statement, 159
- TCPip command, 163
- TRace command, 167
- TREQDef command, 170
- UEXit command, 173
- UNITAttr command, 176
- USERMsg command, 178
- exceptions, SMC allocation, 75
- excluion levels
 - scratch request, 70
 - specific request, 68
- EXEC Statement, SMC, 56

F

- Fujitsu
 - operating system messages, 281

H

- HTTP Server for OS/390 and z/OS
 - CGI parameters, 268
 - configuration parameters, 267
 - customizing parameter file, 267
 - displaying status, 269
 - network parameters, 268
 - scenarios, 33
 - START procedure, 266
 - starting and stopping, 269

I

- initialization, SMC, 53, 265
- intercepted messages
 - Fujitsu operating system messages, 281
 - JES3 messages, 285
 - tape management system messages, 283
- introduction, SMC, 29

J

- JES2 allocation, 76

L

- LIBrary command, 108
- LIst command, 109
- LOG command, 111

M

- message handling, SMC, 77
- messages
 - descriptions, 200
 - DFSMSrmm messages, 284
 - format, 199, 270

- HSC mount-related messages, 80
 - intercepted, 281, 285
 - messages intercepted by HSC, 281
 - SMC system messages, 199, 259
 - SMC utility messages, 256
 - StorageTek HTTP Server messages, 271
 - tape management system messages, 283
 - variable definitions, 200
- Modify command, MSP, 84
- MOUNTDef command, 114
- mounts, managing from the SMC client, 81
- MSGDef command, 117
- MSGJob command, 120
- MSP START Command, 58

O

- one local and one remote, 42
- one local and one remote with multiple paths, 44
- operator commands
 - issuing, 84
 - ALLOCDDef, 87
 - ALLOCJob, 92
 - CMDDef, 96
 - COMMtest, 98
 - Display Drive, 101
 - Display Volume, 104
 - DRIVemap, 106
 - LIBrary, 108
 - LIst, 109
 - LOG, 111
 - MOUNTDef, 114
 - MSGDef, 117
 - MSGJob, 120
 - POLicy, 123
 - READ, 130
 - RESYNChronize, 132
 - Route, 134
 - SERVer, 137
 - STORMNGR, 142
 - TAPEPlex, 144
 - TCPip, 161
 - TRace, 164
 - TREQDef, 169
 - UEXit, 171
 - UNITAttr, 174, 175
 - USERMsg, 177

P

- parameters
 - ALLOCDDef command, 88
 - ALLOCJob command, 93
 - CMDDef command, 96
 - COMMtest command, 99
 - Display DRive command, 102
 - Display Volume command, 104

- DRIVemap command, 107
- LlSt command, 109
- LOG command, 112
- MOUNTDef command, 115
- MSGDef command, 118
- MSGJob command, 120
- MSP START Command, 58
- POLicy command, 125
- READ command, 130
- RESYNChronize command, 133
- Route command, 135
- SERVer command, 138
- SMC EXEC Statement, 56
- STORMNGR command, 143
- TAPEPlex command, 146
- TAPEREQ control statement, 151
- TCPIP command, 161
- TRace command, 165
- TREQDef command, 169
- UEXit command, 172
- UNITAttr command, 175
- USERMsg command, 177
- policy
 - and the TAPEREQ control statement, 60
 - defining using the SMC POLicy command, 59
 - example, 64
- POLicy and Tapereq Batch Test Utility, 195
- POLicy command, 123
- preferencing, device, 157

R

- READ command, 130
- recovery procedures, 179
- RESYNChronize command, 132
- Route command, 134

S

- scratch subpool 0, 70, 126
- SERVer command, 137
- SMC
 - allocation, 65
 - compatibility, 297
 - configuration scenarios, 34
 - control statements, 83
 - drive exclusion, 66
 - drive prioritization, 74
 - functions, 29
 - initializing, 53, 265
 - interaction with other software, 299
 - message handling, 77
 - messages, 199, 259
 - operator commands, 83
 - policy, 59
 - policy and drive type information
 - synchronization, 48

- recovery procedures, 179
- starting, 53, 265
 - TapePlex subsystem selection, 52
 - utilities, 181
- SMCCMDS data set, 85
- SMCPARMS data set, 85
- SMCUUUI Utility, 190
- SSI23 dynamic allocation, 76
- SSI24 common allocation, 76
- START Command, MSP, 58
- START procedure, creating, 54
- starting SMC, 53, 265
- STORMNGR command, 142
- swap processing, SMC, 79
- syntax
 - ALLOCDef command, 87
 - ALLOCJob command, 92
 - CMDDef command, 96
 - COMMtest command, 98
 - Display DRive command, 101
 - Display Volume command, 104
 - DRIVemap command, 106
 - LlSt command, 109
 - LOG command, 111
 - MOUNTDef command, 114
 - MSGDef command, 117
 - MSGJob command, 120
 - MSP START Command, 58
 - POLicy command, 124
 - READ command, 130
 - RESYNChronize command, 132
 - Route command, 134
 - SERVer command, 137
 - SMC EXEC Statement, 56
 - STORMNGR command, 142
 - TAPEPlex command, 145
 - TAPEREQ control statement, 150
 - TCPIP command, 161
 - TRace command, 164
 - TREQDef command, 169
 - UEXit command, 171
 - UNITAttr command, 175
 - USERMsg command, 177

T

- T9940A Cartridge Subsystem, defined, 315
- Tape Management Extract Utility, 182
- Tape Management System (TMS)
 - messages, 283
 - supported, 78
- TAPEPlex command, 144
- TapePlex selection, 52
- TAPEREQ control statement
 - and SMC Policy, 60
 - description, 149

TCPip command, 161
TRace command, 164
TREQDef command, 169

U

UEXit command, 171
UNITAttr command, 174, 175
user exits, allocation, 67
USERMsg command, 177
utilities
 POLicy and Tapereq Batch Test Utility, 195
 SMCUUUI Utility, 190
 Tape Management Extract Utility, 182

V

volume serial numbers, defined, 281